

All-optical UWB generation and modulation using SOA-XPM effect and DWDM-based multi-channel frequency discrimination

Fei Wang,^{1,2} Jianji Dong,¹ Enming Xu,¹ Xinliang Zhang^{1,*}

¹ Wuhan National Laboratory for Optoelectronics & School of Optoelectronic Science and Engineering, Huazhong University of Science and Technology, Wuhan, 430074, P. R. China.

² School of optoelectronic information, Chongqing University of Technology, Chongqing 400050, P. R. China.
*xlzhang@mail.hust.edu.cn

Abstract: An all-optical UWB pulses generation and modulation scheme using cross phase modulation (XPM) effect of semiconductor optical amplifier (SOA) and DWDM-based multi-channel frequency discrimination is proposed and demonstrated, which has potential application in multiuser UWB-Over-Fiber communication systems. When a Gaussian pulse light and a wavelength-tunable CW probe light are together injected into the SOA, the probe light out from the SOA will have a temporal chirp due to SOA-XPM effect. When the chirped probe light is tuned to the slopes of single DWDM channel transmittance curve, the optical phase modulation to intensity modulation conversion is achieved at DWDM that serves as a multi-channel frequency discriminator, the inverted polarity Gaussian monocycle and doublet pulse is detected by a photodetector, respectively. If the probe lights are simultaneously aimed to different slopes of several DWDM channels, multi-channel or binary-phase-coded UWB signal generation can be acquired. Using proposed scheme, pulse amplitude modulation (PAM), pulse polarity modulation (PPM) and pulse shape modulation (PSM) to UWB pulses also can be conveniently realized.



©2010 Optical Society of America

OCIS codes: (060.2330) Fiber optics communications; (060.5625) Radio frequency photonics; (999.9999) Ultra-wide band; (250.4745) Optical processing devices.

References and links

1. R. C. Qiu, H. Liu, and X. Shen, "Ultra-wideband for multiple access communications," *IEEE Commun. Mag.* **43**(2), 80–87 (2005).
2. J. P. Yao, F. Zeng, and Q. Wang, "Photonic generation of ultrawideband signals," *J. Lightwave Technol.* **25**(11), 3219–3235 (2007).
3. Y. Wang, and X. D. Dong, "A TDMA scheme for SC-FDE UWB communications," in *Global Telecommunications Conference, GLOBECOM '05. IEEE*, 3659–3663(2005).
4. S. H. Song, and Q. T. Zhang, "CDMA-PPM for UWB impulse radio," *IEEE Trans. Veh. Technol.* **57**, 1011–1020 (2008).
5. F. Zeng, and J. P. Yao, "Ultrawideband impulse radio signal generation using a high-speed electrooptic phase modulator and a fiber-Bragg-grating-based frequency discriminator," *IEEE Photon. Technol. Lett.* **18**(19), 2062–2064 (2006).
6. F. Zeng, Q. Wang, and J. P. Yao, "All-optical UWB impulse generation based on cross-phase modulation and frequency discrimination," *Electron. Lett.* **43**(2), 119–121 (2007).
7. M. Abtahi, J. Magne, M. Mirshafiei, L. A. Rusch, and S. LaRochelle, "Generation of power-efficient FCC-compliant UWB waveforms using FBGs: Analysis and experiment," *J. Lightwave Technol.* **26**(5), 628–635 (2008).
8. Y. B. Ezra, M. Haridim, B. I. Lembrikov, and M. Ran, "Proposal for All-Optical Generation of Ultra-Wideband Impulse Radio Signals in Mach-Zehnder Interferometer With Quantum-Dot Optical Amplifier," *IEEE Photon. Technol. Lett.* **20**(7), 484–486 (2008).
9. V. Torres-Company, K. Prince, and I. T. Monroy, "Fiber transmission and generation of ultrawideband pulses by direct current modulation of semiconductor lasers and chirp-to-intensity conversion," *Opt. Lett.* **33**(3), 222–224 (2008).

10. J. J. Dong, X. L. Zhang, J. Xu, D. X. Huang, S. N. Fu, and P. Shum, "Ultrawideband monocycle generation using cross-phase modulation in a semiconductor optical amplifier," *Opt. Lett.* **32**(10), 1223–1225 (2007).
11. Q. Wang, and J. P. Yao, "Approach to all-optical bipolar direct-sequence ultrawideband coding," *Opt. Lett.* **33**(9), 1017–1019 (2008).
12. P. Ou, Y. Zhang, and C. X. Zhang, "Optical generation of binary-phase-coded, direct-sequence ultra-wideband signals by polarization modulation and FBG-based multi-channel frequency discriminator," *Opt. Express* **16**(7), 5130–5135 (2008), <http://www.opticsinfobase.org/oe/abstract.cfm?URI=oe-16-7-5130>.
13. Y. T. Dai, and J. P. Yao, "Optical Generation of Binary Phase-Coded Direct-Sequence UWB Signals Using a Multichannel Chirped Fiber Bragg Grating," *J. Lightwave Technol.* **26**(15), 2513–2520 (2008).
14. Y. T. Dai, and J. P. Yao, "High-Chip-Count UWB Biphas Coding for Multiuser UWB-Over-Fiber System," *J. Lightwave Technol.* **27**(11), 1448–1453 (2009).

1. Introduction

Ultra wideband (UWB) has attracted considerable research interests for its applications in short-range high-throughput wireless communications and sensor networks. UWB is approved by the Federal Communications Commission (FCC) for unlicensed use in a spectrum range from 3.1 GHz to 10.6 GHz with a spectral power density less than -41.3 dBm/MHz. In general, there are two types of UWB, i.e. the multiband UWB and the direct-sequence UWB (DS-UWB). DS-UWB is an attractive technique for UWB communications since it is carrier free, therefore there is no need for complicated frequency mixers and local oscillators to down- or up-convert the carrier frequency [1]. To realize uninterrupted service across different networks and high-data-rate access at any time and from any place, it is highly desirable that the



WB signals can be generated directly in the optical domain without extra electrical-to-optical conversion [2].

In a multiple access UWB communications system, users transmit information independently and concurrently over a shared channel. Therefore, the received signal is a superposition of all user signals with added channel noise. There has been extensive research in separating multiple users in a multiple access UWB system using time division multiple access (TDMA) or code division multiple access (CDMA) techniques [3,4]. UWB pulses generation and coding in the optical domain for single or multi-user UWB-Over-Fiber communications systems have also acquired increasingly attention. An optical UWB pulse generator based on the optical phase modulation (PM) to intensity modulation (IM) conversion by use of an electrooptic phase modulator (EOPM) and a fiber Bragg grating (FBG) serving as an optical frequency discriminator that can shape the input Gaussian pulses into monocycle or doublet pulses was proposed and experimentally demonstrated [5]. All-optical UWB impulse generation based on optical XPM effect in a dispersion shifted fiber (DSF) and frequency discrimination with FBG was also demonstrated [6]. A approach was proposed to generate UWB pulses that is both FCC compliant and maximizes the transmitted power by using a length of single-mode fiber (SMF) to disperse the signal for achieving the frequency-to-time conversion and an FBG for pulse shaping [7]. An approach to all-optical generation of UWB impulse radio signals based on cross-phase modulation (XPM) and cross-gain modulation (XGM) in an asymmetric integrated Mach-Zehnder interferometer (MZI) containing quantum-dot semiconductor optical amplifier (SOA) was presented and demonstrated [8]. A method to generate UWB pulses based on chirp-to-intensity conversion using a distributed feedback (DFB) laser whose driving current is modulated by the electrical data signal was proposed [9]. A novel scheme for generating UWB monocycle pulses based on XPM of a SOA and frequency discrimination with an optical bandpass filter (OBF) was proposed and demonstrated. However, UWB doublet pulses cannot be obtained with OBF-based frequency discriminator [10]. An approach to all-optical bipolar direct-sequence UWB encoding based on EOPM and FBG array that serves as a multichannel frequency discriminator for multiple access communications was proposed and demonstrated [11]. Phase coded UWB sequence generator for multiple-access UWB communications based on a polarization modulator (PolM) or phase modulator and an FBG-based multi-channel frequency discriminator was demonstrated [12–14], avoiding using bulky FBG array with low stability.

In this paper, an all-optical UWB pulses generation and modulation scheme based on SOA-XPM effect and DWDM-based multi-channel frequency discriminator is proposed and experimentally demonstrated, which has potential applications in multiuser UWB-Over-Fiber communication systems. When a Gaussian pulse light and a wavelength-tunable continuous wave (CW) probe light are together injected into the SOA, the probe light out from the SOA will have a temporal chirp due to XPM effect. If the wavelength of the chirped probe light is tuned to the linear slope of DWDM channel transmittance curve, the inverted polarity monocycle Gaussian pulse is detected by a photodetector (PD) at the corresponding output port, respectively; If the wavelength of the chirped probe light is aimed to the quadrature slope of DWDM channel transmittance curve, the inverted polarity Gaussian doublet pulse is also acquired, respectively. If the probe lights are simultaneously aimed to different slopes of several DWDM channels transmittance curves, multi-channel or binary-phase-coded UWB signal generation can be obtained. Moreover, using proposed scheme, pulse amplitude modulation (PAM), pulse polarity modulation (PPM) and pulse shape modulation (PSM) to UWB optical pulse can be conveniently realized. Our method has many distinct advantages, such as simple and compact structure, easy integration, low power consumption, flexible modulation, and multi-channel operation.

2. Experiment setup and principle

Figure 1 shows schematic diagram of all-optical multiuser UWB communication system using SOA-XPM effect and DWDM-based frequency discriminator. In central station (CS), the tunable laser array (TL1, TL2...) launch CW probe lights with different wavelength, which are coupled via an optical coupler (OC1, with a splitting ratio of 50:50). TL0 emits CW light located at 1563.5 nm, which is modulated by a Mach-Zehnder modulator (MZM) to form optical Gaussian pulses, and a bit pattern generator (BPG) drives the MZM at a repetition rate of 20 Gb/s with a fixed pattern "1000 0000 0000 0000" (one "1" per 16 bits), which is equivalent to a Gaussian pulse train with a repetition rate of 1.25 GHz. Via the OC2, the Gaussian pulse train and the CW probe lights are simultaneously injected into the SOA biased at 180 mA with low polarization dependence (< 0.5 dB). Then, the chirped probe lights are tuned to the different operating point of the DWDM with channel spacing of 100 GHz and 3-dB channel bandwidth of 0.40 nm. Generated UWB signals are distributed to base stations (BSs) through fiber links from different DWDM channels. BS is formed by a pin photodetector (PIN-PD) and a power amplifier (PA), in which optical signal is converted into electrical signal, and is monitored by a digital communication analyzer (DCA) and an electrical spectrum analyzer (ESA).

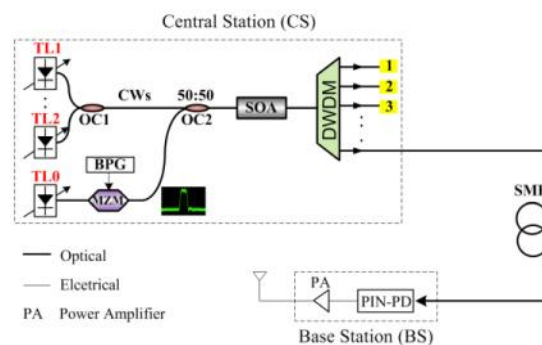

Fig. 1. Schematic diagram of all-optical multiuser UWB communication system.

When a CW probe light generated by TL1 and an optical Gaussian pulse generated by TL0 and the MZM are coupled and launched into the SOA, due to SOA-XPM effect, the probe light is phase modulated by the optical Gaussian pulse in the SOA, and have a phase variation similar

to the input Gaussian pulse. The probe light has a temporal chirp, which is the first-order derivative of the phase variation. Since the temporal phase keeps changing approximately in proportion to the input Gaussian pulse, the chirp of the probe signal has a monocycle shape [10]. DWDM has a frequency response with a super-Gaussian transfer function and can implement PM-IM conversion. Figure 2 shows the transfer function of a DWDM channel. When the wavelength of the chirped probe light is tuned to the left linear slope of the DWDM channel transmittance curve, the positive monocycle Gaussian pulse is detected by the PD (Point A in Fig. 2). Due to the symmetry of the transfer function, the output pulse will be monocycle with a π phase difference when the probe carrier is located at the negative slope of the DWDM transmission spectrum (Point D in Fig. 2). This property permits to implement PPM when two optical carriers corresponding to the inverted polarity UWB pulses are employed. When the optical carrier is located at the quadrature slopes of the DWDM transmittance response, as shown in Fig. 2 at B and C, the inverted polarity doublet pulses will be generated, respectively. Therefore, by locating the optical carrier at different operating point of DWDM channel, UWB pulses with different shapes (monocycle-doublet) can be generated, therefore, the implementation of another pulse modulation scheme, i.e., PSM, is also possible.

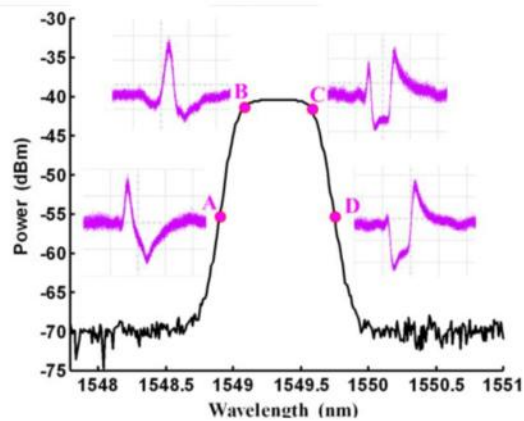

Fig. 2. Transfer function of a DWDM channel

3. Results and discussion

The SOA is biased on 180 mA and can provide small signal gain of about 14 dB. The Gaussian pulse train locates at 1563.5 nm, and has a full width of half maximum (FWHM) of 70 ps and a peak power of 1.5 mW. **When the wavelength of the tunable probe laser is targeted at different operating point in the DWDM channel with center wavelength of 1549.3 nm, the inverted polarity UWB monocycle and doublet pulse is obtained, respectively.** The measured waveforms and electrical spectra of the acquired UWB monocycle and doublet pulses are shown in Fig. 3. Figure 3(a) depicts the waveform of the positive polarity UWB monocycle pulse. The upper FWHM and the lower FWHM are 30 and 46 ps, respectively. Figure 3(b) shows that the corresponding electrical spectrum has a central frequency of 6.25 GHz and a 10-dB bandwidth of 10.00 GHz, thus, the fractional bandwidth is 160%. Figure 3(c), (d) shows the waveform and electrical spectrum of the obtained negative polarity UWB monocycle pulse, respectively. The upper FWHM and the lower FWHM are 36 and 68 ps, respectively. The central frequency is 5.62 GHz with a 10-dB bandwidth of 8.73 GHz, thus, the fractional bandwidth is 155%. Figure 3(e) depicts the waveform of the positive polarity UWB doublet pulse. The lower FWHM of the doublet pulses is 63 ps. Figure 3(f) shows the corresponding electrical spectrum. The central frequency is 6.25 GHz, and the 10-dB bandwidth is 10.00 GHz, therefore, the fractional bandwidth is 160%. Figure 3(g), (h) shows the waveform and electrical

spectrum of the negative polarity UWB doublet pulse, respectively. The upper FWHM of the doublet pulses is 69 ps. The central frequency is 8.75 GHz with a 10-dB bandwidth of 12.5 GHz, therefore the fractional bandwidth is 142%.

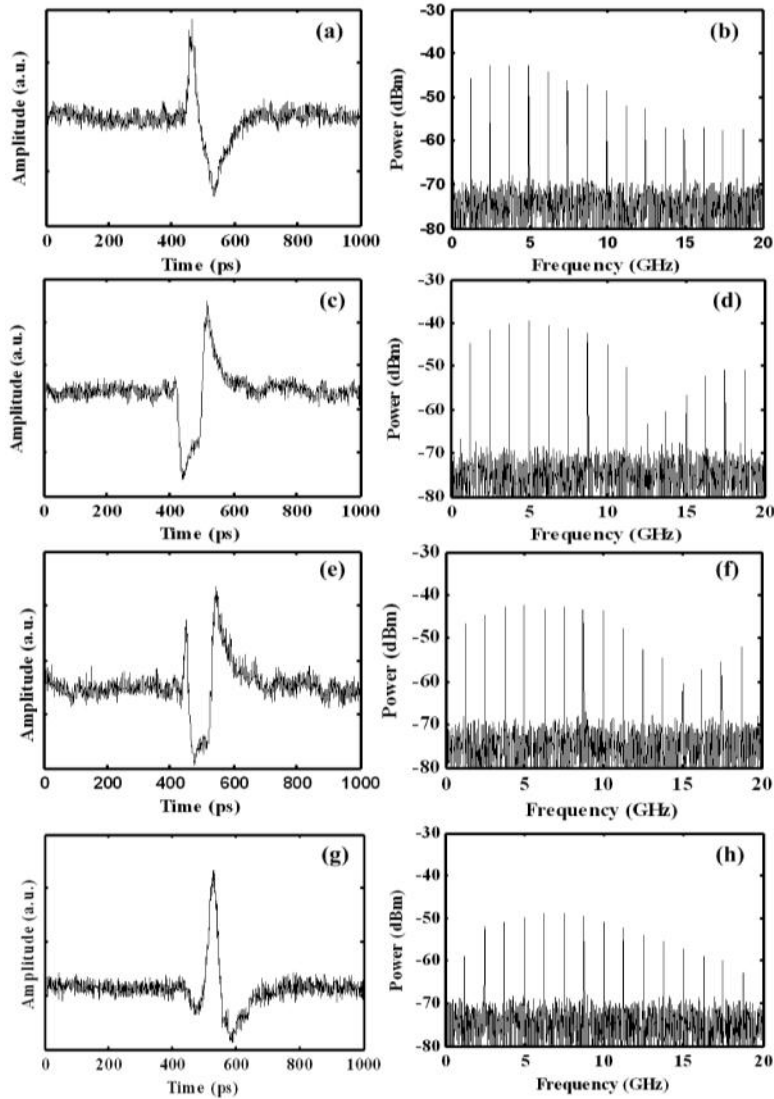

Fig. 3. Measured waveforms and electrical spectra of acquired the inverted polarity UWB monocyte and doublet pulses in a single DWDM channel.

The proposed scheme can also be used to generate binary-phase-coded UWB signal, due to limited experimental conditions, only the dual-channel UWB signal generation is demonstrated. When the two-channel probe lights with wavelength separation of 1.6 nm are simultaneously injected into the two adjacent DWDM channels (Channel 1, Channel 2, see Fig. 1), and were aligned to the positive and negative linear slope of DWDM channel frequency response curve, the positive and negative polarity UWB monocyte pulses are simultaneously acquired at the out ports of the two according channels. Measured waveforms and electrical spectra of the UWB monocyte pulses acquired in Channel 1 and Channel 2 are shown in Fig. 4. Figure 4 (a) depicts the waveform of the positive polarity UWB monocyte pulse acquired in Channel 1 located at 1548.5 nm. The upper FWHM and the lower FWHM are 30 and 40 ps,

respectively. Figure 4(b) shows that the corresponding electrical spectrum has a central frequency of 6.25 GHz and a 10-dB bandwidth of 10.00 GHz, thus, the fractional bandwidth is 160%. Figure 4(c), (d) shows the waveform and electrical spectrum of the negative polarity UWB monocycle pulse obtained in Channel 2 located at 1549.3 nm, respectively. The upper FWHM and the lower FWHM are 36 and 68 ps, respectively. The central frequency is 5.62 GHz with a 10-dB bandwidth of 8.73 GHz, thus, the fractional bandwidth is 155%. We also investigated that wavelength separation effect on crosstalk between channels. When the two-channel probe lights with wavelength separation of 0.75 nm were simultaneously injected, and were aligned to the right quadrature slope of Channel 1 and positive linear slope of Channel 3, the positive polarity UWB doublet and monocycle pulses were simultaneously acquired. But when wavelength separation was lower than 0.75 nm, XGM effect of the SOA had seriously affected the multi-channel operation. In the proposed scheme, channel number that can be operated simultaneously mainly depends on the minimum channel spacing and effective range of SOA-XPM. Therefore, operation with dozens of channels can be expected. Moreover, since XPM effect in SOA depends on light intensity and wavelength separation, the crosstalk between the adjacent probe lights with relative low intensity will be not increased too much when more channels are added.

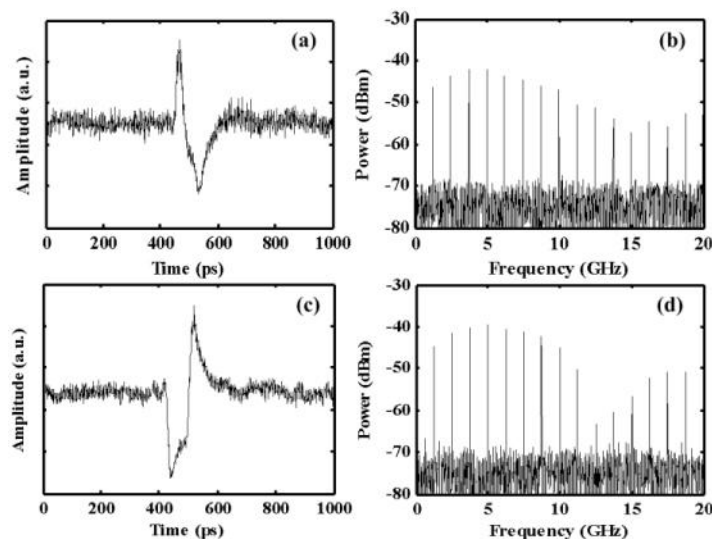

Fig. 4. Measured waveforms and electrical spectra of the UWB monocycle pulses simultaneously acquired in the two adjacent DWDM channels.

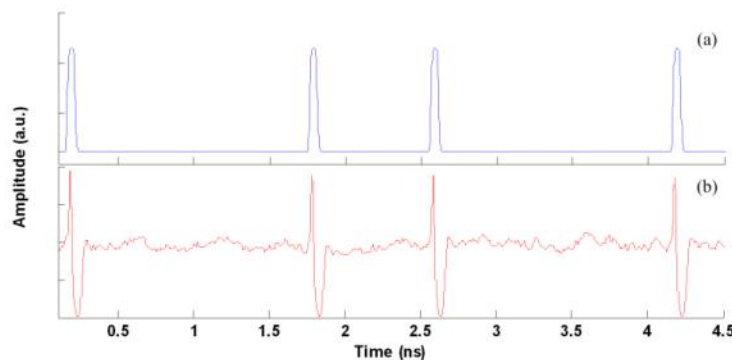

Fig. 5. Numerical result of implement PAM for UWB pulses. Bit sequence of the control optical signal (a) and the modulated UWB signal (b).

If the Gaussian pulse train is replaced by an optical on-off keying (OOK) signal with PRBS data signals in previous experiment, PAM for UWB pulses can be conveniently realized. The principle of PAM can be depicted as follows. When the coming signals are “1s”, the probe light will be phase modulated, in the corresponding time, a UWB monocycle/doublet pulse will be generated; when the coming signal is “0”, the probe light will not be phase modulated, therefore, no UWB pulse is generated. By this means, the information included in the control optical signal is transferred into the generated UWB pulse signal. In the actual application, the control optical data also can be directly downloaded in the optical communication network. Since the used transmitter cannot produce a return-to-zero (RZ) data stream less than 10-GHz with a fixed bit, we use Optisystem 7.0 to simulate that this scheme is used to implement PAM for UWB pulses. The numerical result is shown in Fig. 5. Figure 5(a) describes bit sequence of the control optical signal. The control optical signal has a bit rate of 1.25 GHz. Figure 5(b) describes bit sequence of the modulated UWB signal. If the wavelength of the probe light is tuned to the different operating point of DWDM channel, UWB modulation pulses with other shapes also can be produced.

4. Conclusion

An all-optical UWB pulses generation and modulation schemes for multiuser UWB-Over-Fiber communications have been proposed and experimentally and numerically demonstrated. The proposed system was based on the optical PM-IM conversion that was realized by use of SOA-XPM effect and a DWDM serving as a multi-channel optical frequency discriminator. By locating the probe light at different slopes of the DWDM transmittance spectrum, UWB pulses with the inverted polarity or different shapes were obtained. This feature makes PPM and PSM schemes for UWB pulses possible. The proposed scheme can also be used to generate binary-phase-coded and multi-channel UWB signal due to using DWDM with periodic transmittance spectra. PAM for UWB pulses had been demonstrated by introducing a control optical data similarly exploiting SOA-XPM effect.

Acknowledgement

This work was partly supported by the National Natural Science Foundation of China under Grant 60877056, 61007064 and 60901006, and the Huawei Foundation under Grant YJCB2008033TR. The authors also gratefully acknowledge the support from the Commission of Education of Chongqing City of P. R. China (KJ 100816).