



Fiber-Optic Communication Systems

Govind P. Agrawal

Institute of Optics
University of Rochester

email: gpa@optics.rochester.edu



Back

Close

Course Outline

- Introduction, Modulation Formats
- Fiber Loss, Dispersion, and Nonlinearities
- Receiver Noise and Bit Error Rate
- Loss Management: Optical Amplifiers
- Dispersion Management Techniques
- Management of Nonlinear Effects
- WDM Lightwave Systems



2/66



Back

Close

Historical Perspective

Electrical Era

- Telegraph; 1836
- Telephone; 1876
- Coaxial Cables; 1840
- Microwaves; 1948

Optical Era

- Optical Fibers; 1978
- Optical Amplifiers; 1990
- WDM Technology; 1996
- Multiple bands; 2002

- Microwaves and coaxial cables limited to $B \sim 100$ Mb/s.
- Optical systems can operate at bit rate >10 Tb/s.
- Improvement in system capacity is related to the high frequency of optical waves (~ 200 THz at $1.5 \mu\text{m}$).



3/66



Back

Close

Information Revolution

- Industrial revolution of 19th century gave way to information revolution during the 1990s.
- Fiber-Optic Revolution is a natural consequence of the Internet growth.

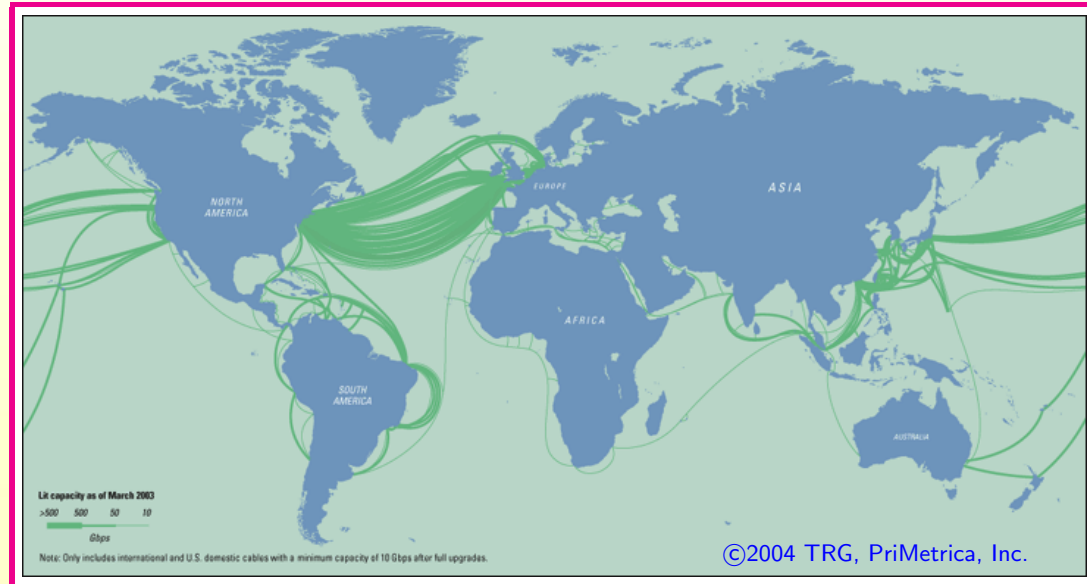

4/66



Back

Close

Five Generations

- 0.8- μm systems (1980); Graded-index fibers
- 1.3- μm systems (1985); Single-mode fibers
- 1.55- μm systems (1990); Single-mode lasers
- WDM systems (1996); Optical amplifiers
- L and S bands (2002); Raman amplification

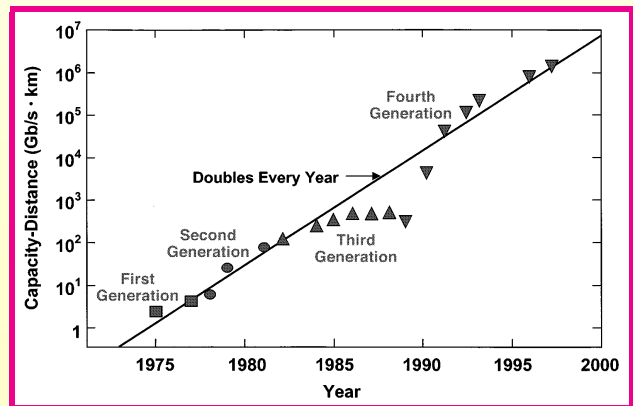
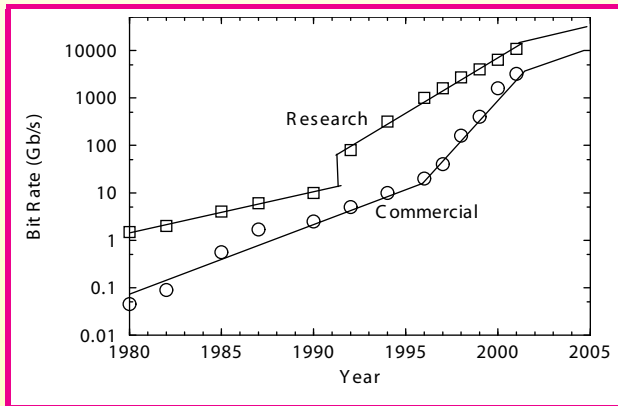

Lightwave System Components

Generic System



Transmitter and Receiver Modules

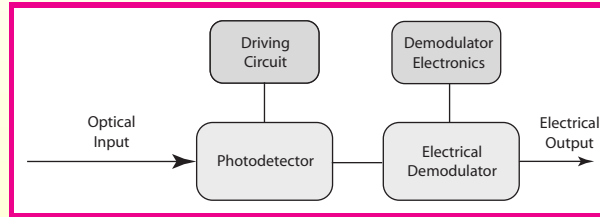
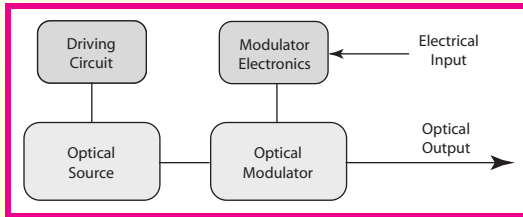

Fiber-Optic Communication Channel

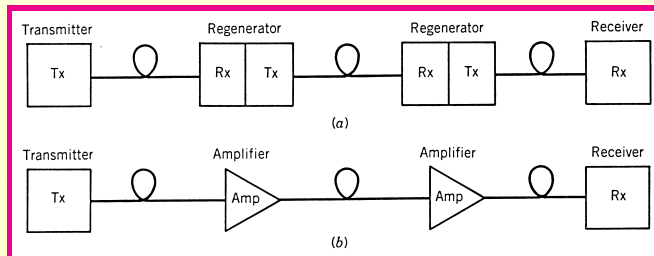



Modulation Formats

Optical Carrier has the form

$$\mathbf{E}(t) = \hat{\mathbf{e}}A \cos(\omega_0 t + \phi)$$

- Amplitude-shift keying (ASK): modulate A
- Frequency-shift keying (FSK): modulate ω_0
- Phase-shift keying (PSK): modulate ϕ
- Polarization-shift keying (PoSK): information encoded in the polarization state $\hat{\mathbf{e}}$ of each bit (not practical for optical fibers).
 - ★ Most lightwave systems employ ASK.
 - ★ ASK is also called on–of keying (OOK).
 - ★ Differential PSK (DPSK) is being studied in recent years.



Back

Close

Optical Bit Stream

- Return-to-zero (RZ)
- nonreturn-to-zero (NRZ)

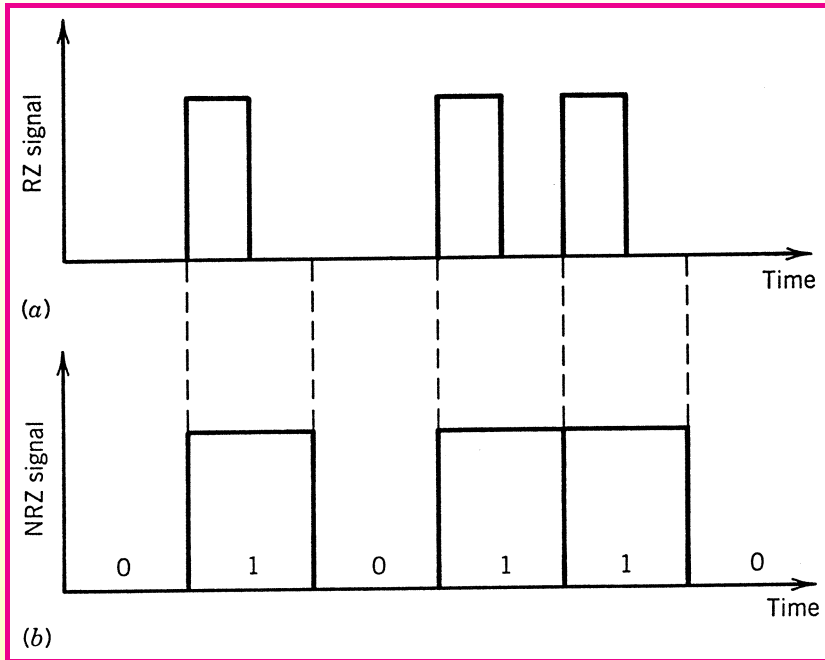

8/66



Back

Close

Bit-Stream Generation

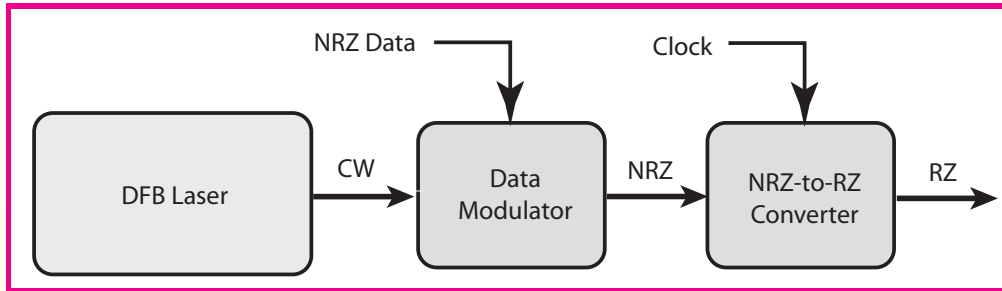

LiNbO₃ Modulators

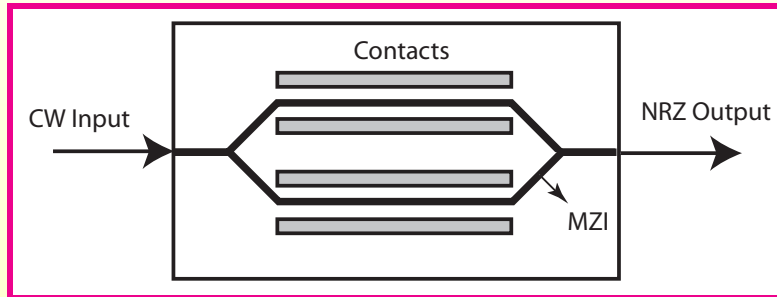

- Employ a Mach-Zehnder for PM to AM conversion.
- RZ Duty Cycle is 50% or 33% depending on biasing.





Variants of RZ Format

- Optical phase is changed selectively in addition to amplitude.
- Three-level or ternary codes: 1 0 -1 bits
- **CSRZ format**: Phase of alternate bits is shifted by π .
- **Alternate-phase (AP-RZ)**: Phase shift of $\pi/2$ for alternate bits.
- **Alternate mark inversion**: Phase of alternate 1 bits shifted by π .
- **Duobinary format**: Phase shifted by π after odd number of zeros.

- **RZ-DPSK format**: Information encoded in phase variations
- Phase difference $\phi_k - \phi_{k-1}$ is changed by 0 or π depending on whether k th bit is a 0 or 1.



Back

Close

DPSK Transmitters and Receivers

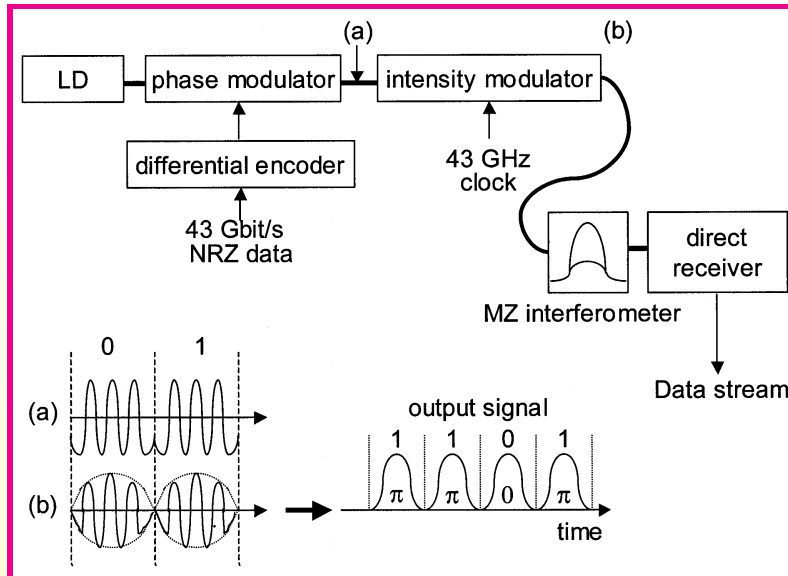

- Two modulators used at the transmitter end; second modulator is called a “pulse carver.”
- A Mach–Zehnder interferometer employed at receiver to convert phase information into current variations.

Comparison of Signal Spectra

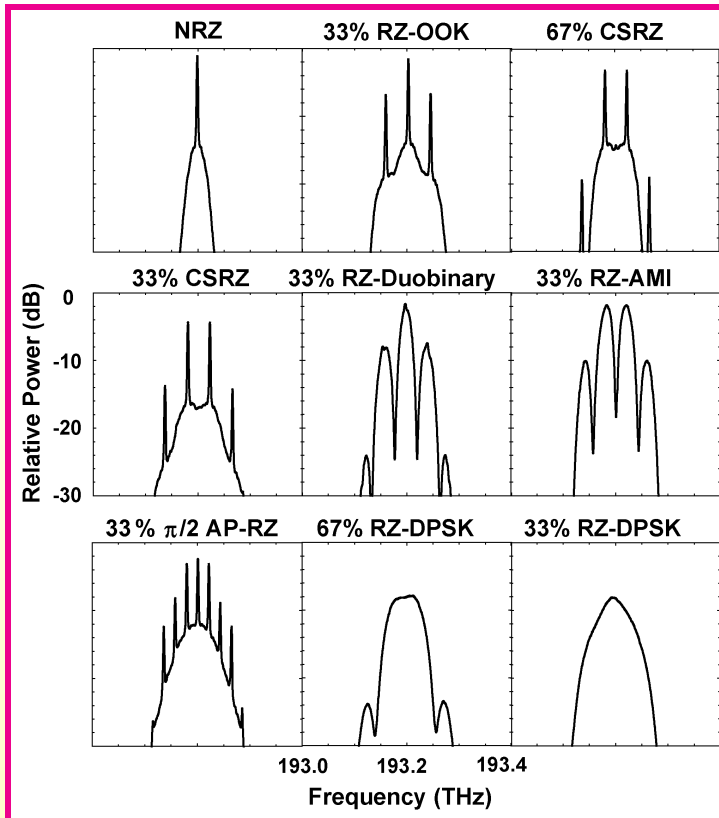

12/66



Back

Close



Optical Fibers

- Most suitable as communication channel because of dielectric waveguiding (acts like an optical wire).
- Total internal reflection at the core-cladding interface confines light to fiber core.
- Single-mode propagation for core size $< 10 \mu\text{m}$.

What happens to optical signal?

- Fiber losses limit the transmission distance (minimum loss near $1.55 \mu\text{m}$).
- Chromatic dispersion limits the bit rate through pulse broadening.
- Nonlinear effects distort the signal and limit the system performance.



Fiber Losses

Definition: $\alpha(\text{dB/km}) = -\frac{10}{L} \log_{10} \left(\frac{P_{\text{out}}}{P_{\text{in}}} \right) \approx 4.343\alpha$.

- Material absorption (silica, impurities, dopants)
- Rayleigh scattering (varies as λ^{-4})
- Waveguide imperfections (macro and microbending)

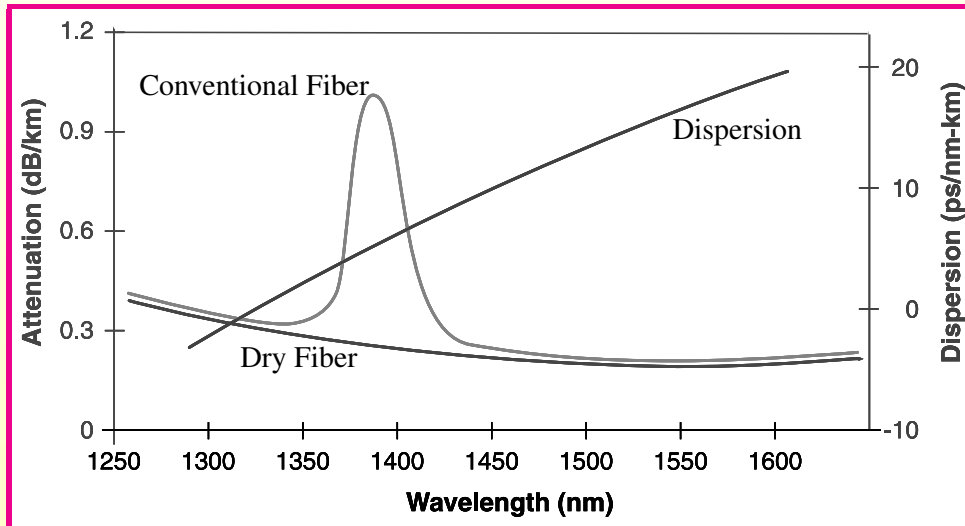

Fiber Dispersion

Origin: Frequency dependence of the mode index $n(\omega)$:

$$\beta(\omega) = \bar{n}(\omega)\omega/c = \beta_0 + \beta_1(\omega - \omega_0) + \beta_2(\omega - \omega_0)^2 + \dots,$$

where ω_0 is the carrier frequency of optical pulse.

- *Transit time* for a fiber of length L : $T = L/v_g = \beta_1 L$.
- Different frequency components travel at different speeds and arrive at different times at the output end (pulse broadening).

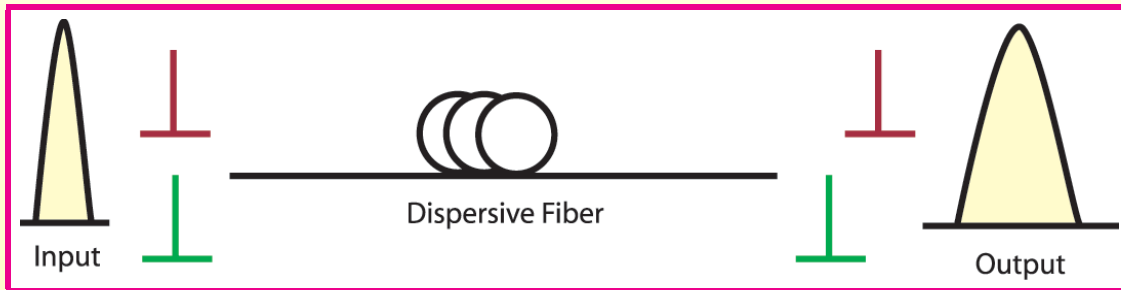



Fiber Dispersion (continued)

Pulse broadening governed by group-velocity dispersion:

$$\Delta T = \frac{dT}{d\omega} \Delta\omega = \frac{d}{d\omega} \frac{L}{v_g} \Delta\omega = L \frac{d\beta_1}{d\omega} \Delta\omega = L\beta_2 \Delta\omega,$$

where $\Delta\omega$ is pulse bandwidth and L is fiber length.

- GVD parameter: $\beta_2 = \left(\frac{d^2\beta}{d\omega^2} \right)_{\omega=\omega_0}$.
- Alternate definition: $D = \frac{d}{d\lambda} \left(\frac{1}{v_g} \right) = -\frac{2\pi c}{\lambda^2} \beta_2$.
- Limitation on the bit rate: $\Delta T < T_B = 1/B$, or

$$B(\Delta T) = BL\beta_2\Delta\omega \equiv BLD\Delta\lambda < 1.$$

- Dispersion limits the BL product for any lightwave system.



Back

Close



Higher-Order Dispersion

- Dispersive effects do not disappear at $\lambda = \lambda_{\text{ZD}}$.
- D cannot be made zero at all frequencies within the pulse spectrum.
- Higher-order dispersive effects are governed by the dispersion slope $S = dD/d\lambda$.
- S can be related to third-order dispersion β_3 as

$$S = (2\pi c/\lambda^2)^2\beta_3 + (4\pi c/\lambda^3)\beta_2.$$

- At $\lambda = \lambda_{\text{ZD}}$, $\beta_2 = 0$, and S is proportional to β_3 .
- Typical values: $S \sim 0.05\text{--}0.1 \text{ ps}/(\text{km}\cdot\text{nm}^2)$.



Back

Close



Polarization-Mode Dispersion

- Real fibers exhibit some birefringence ($\bar{n}_x \neq \bar{n}_y$).
- Orthogonally polarized component travel at different speeds.
Relative delay for fiber of length L is given by

$$\Delta T = \left| \frac{L}{v_{gx}} - \frac{L}{v_{gy}} \right| = L |\beta_{1x} - \beta_{1y}| = L(\Delta\beta_1).$$

- Birefringence varies randomly along fiber length (PMD) because of stress and core-size variations.
- Root-mean-square Pulse broadening:

$$\sigma_T \approx (\Delta\beta_1) \sqrt{2l_c L} \equiv D_p \sqrt{L}.$$

- PMD parameter $D_p \sim 0.01\text{--}10 \text{ ps}/\sqrt{\text{km}}$
- PMD can degrade system performance considerably (especially for old fibers and at high bit rates).



Commercial Fibers

Parameter values for some commercial fibers

Fiber Type and Trade Name	A_{eff} (μm^2)	λ_{ZD} (nm)	D (C band) ps/(km-nm)	Slope S ps/(km-nm ²)
Corning SMF-28	80	1302–1322	16 to 19	0.090
Lucent AllWave	80	1300–1322	17 to 20	0.088
Alcatel ColorLock	80	1300–1320	16 to 19	0.090
Corning Vascade	101	1300–1310	18 to 20	0.060
TrueWave-RS	50	1470–1490	2.6 to 6	0.050
Corning LEAF	72	1490–1500	2 to 6	0.060
TrueWave-XL	72	1570–1580	−1.4 to −4.6	0.112
Alcatel TeraLight	65	1440–1450	5.5 to 10	0.058



19/66



Back

Close



Pulse Propagation Equation

- Neglecting third-order dispersion, pulse evolution is governed by

$$\frac{\partial A}{\partial z} + \frac{i\beta_2}{2} \frac{\partial^2 A}{\partial t^2} = 0.$$

- Compare it with the paraxial equation governing diffraction:

$$2ik \frac{\partial A}{\partial z} + \frac{\partial^2 A}{\partial x^2} = 0.$$

- Slit-diffraction problem identical to pulse propagation problem.
- The only difference is that β_2 can be positive or negative.
- Many results from diffraction theory can be used for pulses.
- A Gaussian pulse should spread but remain Gaussian in shape.



Dispersion Limitations

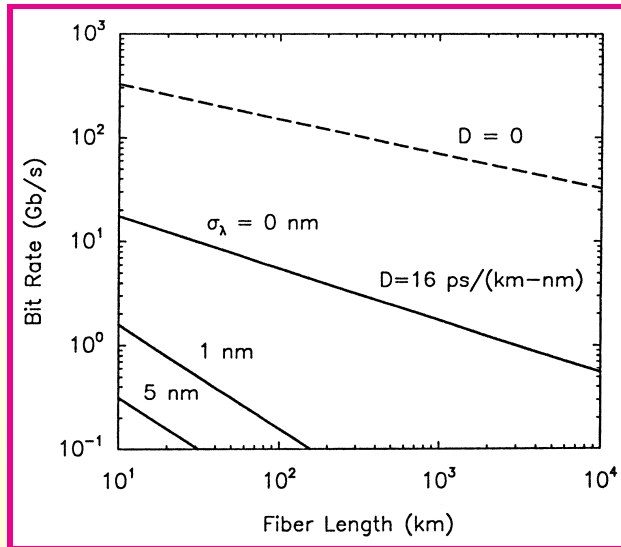

- Even a 1-nm spectral width limits $BL < 0.1$ (Gb/s)-km.
- DFB lasers essential for most lightwave systems.
- For $B > 2.5$ Gb/s, dispersion management required.



21/66



Back

Close



Major Nonlinear Effects

- Stimulated Raman Scattering (SRS)
- Stimulated Brillouin Scattering (SBS)
- Self-Phase Modulation (SPM)
- Cross-Phase Modulation (XPM)
- Four-Wave Mixing (FWM)

Origin of Nonlinear Effects in Optical Fibers

- Ultrafast third-order susceptibility $\chi^{(3)}$.
- Real part leads to SPM, XPM, and FWM.
- Imaginary part leads to SBS and SRS.



Back

Close



Nonlinear Schrödinger Equation

- Nonlinear effects can be included by adding a nonlinear term to the equation used earlier for dispersive effects.
- This equation is known as the Nonlinear Schrödinger Equation:

$$\frac{\partial A}{\partial z} + \frac{i\beta_2}{2} \frac{\partial^2 A}{\partial t^2} = i\gamma|A|^2 A.$$

- Nonlinear parameter: $\gamma = 2\pi\bar{n}_2/(A_{\text{eff}}\lambda)$.
- Fibers with large A_{eff} help through reduced γ .
- Known as large effective-area fiber or LEAF.
- Nonlinear effects leads to formation of optical solitons.



Optical Receivers

- A photodiode converts optical signal into electrical domain.
- Amplifiers and filters shape the electrical signal.
- A decision circuit reconstructs the stream of 1 and 0 bits.

- Electrical and optical noises corrupt the signal.
- Performance measured through bit error rate (BER).
- $BER < 10^{-9}$ required for all lightwave systems.

- **Receiver sensitivity:** Minimum amount of optical power required to realize the desirable BER.



24/66



Back

Close

Bit Error Rate

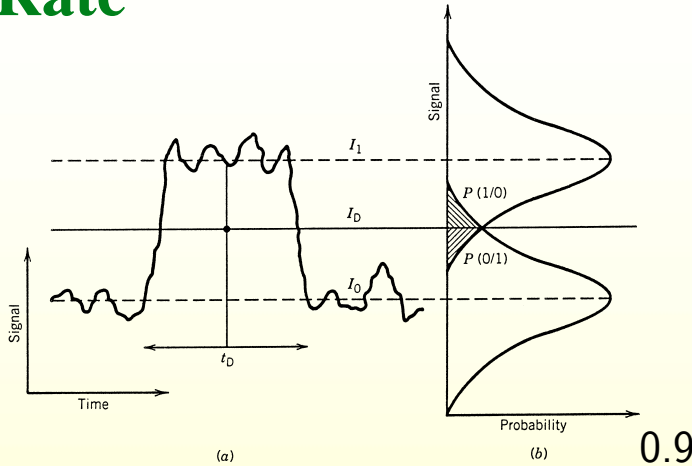

- BER = Error probability per bit

$$\text{BER} = p(1)P(0/1) + p(0)P(1/0) = \frac{1}{2}[P(0/1) + P(1/0)].$$

- $P(0/1)$ = conditional probability of deciding 0 when 1 is sent.
- Since $p(1) = p(0) = 1/2$, $\text{BER} = \frac{1}{2}[P(0/1) + P(1/0)]$.
- It is common to assume Gaussian statistics for the current.





Bit Error Rate (continued)

- $P(0/1)$ = Area below the decision level I_D

$$P(0/1) = \frac{1}{\sigma_1 \sqrt{2\pi}} \int_{-\infty}^{I_D} \exp\left(-\frac{(I - I_1)^2}{2\sigma_1^2}\right) dI = \frac{1}{2} \operatorname{erfc}\left(\frac{I_1 - I_D}{\sigma_1 \sqrt{2}}\right).$$

- $P(1/0)$ = Area above the decision level I_D

$$P(1/0) = \frac{1}{\sigma_0 \sqrt{2\pi}} \int_{I_D}^{\infty} \exp\left(-\frac{(I - I_0)^2}{2\sigma_0^2}\right) dI = \frac{1}{2} \operatorname{erfc}\left(\frac{I_D - I_0}{\sigma_0 \sqrt{2}}\right).$$

- Complementary error function $\operatorname{erfc}(x) = \frac{2}{\sqrt{\pi}} \int_x^{\infty} \exp(-y^2) dy$.
- Final Answer

$$\operatorname{BER} = \frac{1}{4} \left[\operatorname{erfc}\left(\frac{I_1 - I_D}{\sigma_1 \sqrt{2}}\right) + \operatorname{erfc}\left(\frac{I_D - I_0}{\sigma_0 \sqrt{2}}\right) \right].$$



Back

Close



Bit Error Rate (continued)

- BER depends on the decision threshold I_D .
- Minimum BER occurs when I_D is chosen such that

$$\frac{(I_D - I_0)^2}{2\sigma_0^2} = \frac{(I_1 - I_D)^2}{2\sigma_1^2} + \ln\left(\frac{\sigma_1}{\sigma_0}\right).$$

- Last term negligible in most cases, and

$$(I_D - I_0)/\sigma_0 = (I_1 - I_D)/\sigma_1 \equiv Q.$$

$$I_D = \frac{\sigma_0 I_1 + \sigma_1 I_0}{\sigma_0 + \sigma_1}, \quad Q = \frac{I_1 - I_0}{\sigma_1 + \sigma_0}.$$

- Final Expression for BER

$$\text{BER} = \frac{1}{2} \operatorname{erfc}\left(\frac{Q}{\sqrt{2}}\right) \approx \frac{\exp(-Q^2/2)}{Q\sqrt{2\pi}}.$$



Q Factor

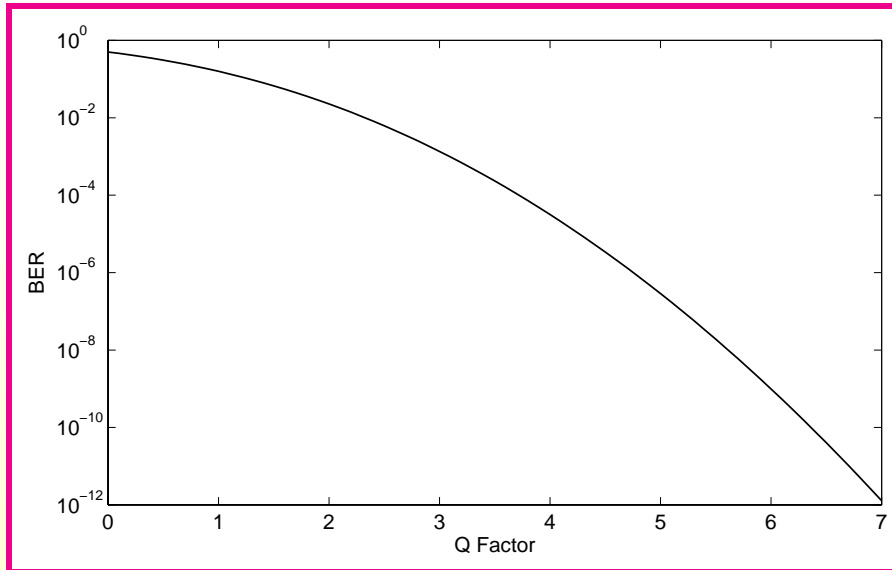

- $Q = \frac{I_1 - I_0}{\sigma_1 + \sigma_0}$ is a measure of SNR.
- $Q > 6$ required for a BER of $< 10^{-9}$.
- Common to use dB scale: $Q^2(\text{in dB}) = 20 \log_{10} Q$





Forward Error Correction

- Widely used for electrical devices dealing with transfer of digital data (CD and DVD players, hard drives).
- Errors corrected at the receiver without retransmission of bits.
- Requires addition of extra bits at the transmitter end using a suitable error-correcting codes: $\text{Overhead} = B_e/B - 1$.
- Examples: Cyclic, Hamming, Reed–Solomon, and turbo codes.
- Reed–Solomon (RS) codes most common for lightwave systems.
- RS(255, 239) with an overhead of 6.7% is often used; RS(255, 207) has an overhead of 23.2%.
- Redundancy of a code is defined as $\rho = 1 - B/B_e$.



Loss Management

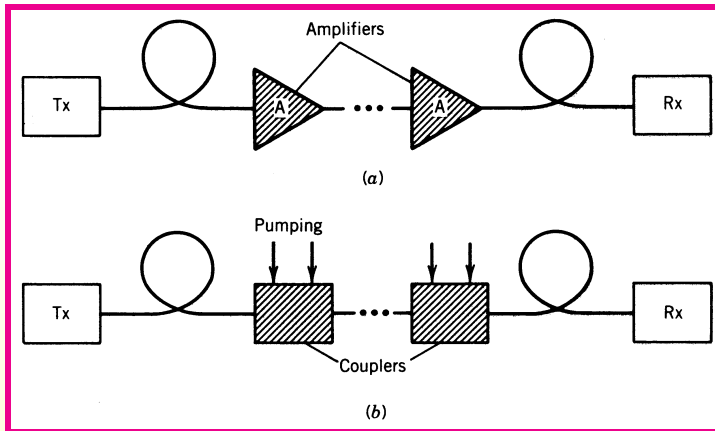

- Periodic regeneration of bit stream expensive for WDM systems:

$$\text{Regenerator} = \text{Receiver} + \text{Transmitter}$$
- After 1990, periodic placement of optical amplifiers was adopted.
- Amplifier spacing is an important design parameter.
- Distributed amplification offers better performance.



Optical Amplifiers

- Used routinely for loss compensation since 1995.
- Amplify input signal but also add some noise.
- Several kinds of amplifiers have been developed.
 - ★ Semiconductor optical amplifiers
 - ★ Erbium-doped fiber amplifiers
 - ★ Raman fiber amplifiers
 - ★ Fiber-Optic parametric amplifiers
- EDFAs are used most commonly for lightwave systems.
- Raman amplifiers work better for long-haul systems.
- Parametric amplifiers are still at the research stage.



Amplifier Noise

- Optical amplifiers introduce noise and degrade SNR.
- Source of noise: Spontaneous emission

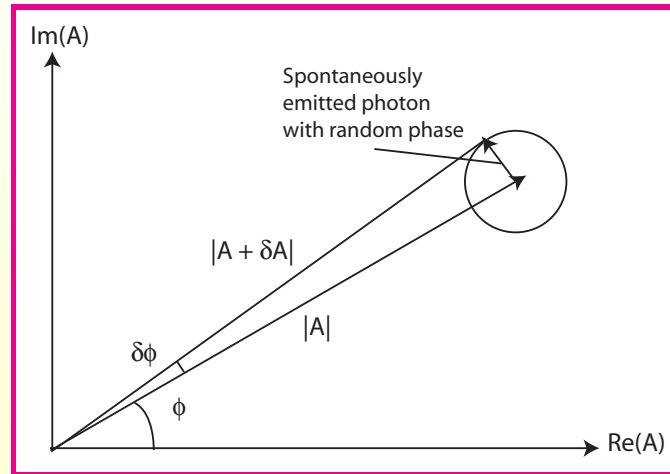

- Noise spectral density $S_{sp}(\nu) = (G - 1)n_{sp}h\nu$.
- Population inversion factor $n_{sp} = N_2 / (N_2 - N_1) > 1$.



32/66



Back

Close



Amplifier Noise Figure

- Noise figure F_n is defined as $F_n = \frac{(\text{SNR})_{\text{in}}}{(\text{SNR})_{\text{out}}}$.
- Beating of signal and spontaneous emission produces

$$I = R|\sqrt{G}E_{\text{in}} + E_{\text{sp}}|^2 \approx RGP_{\text{in}} + 2R(GP_{\text{in}}P_{\text{sp}})^{1/2} \cos \theta.$$

- Randomly fluctuating phase θ reduces SNR.
- Noise figure of lumped amplifiers

$$F_n = 2n_{\text{sp}} \left(1 - \frac{1}{G} \right) + \frac{1}{G} \approx 2n_{\text{sp}}.$$

- SNR degraded by 3 dB even for an ideal amplifier.
- SNR degraded considerably for a chain of cascaded amplifiers.





ASE-Induced Timing Jitter

- Amplifiers induce timing jitter by shifting pulses from their original time slot in a random fashion.
- This effect was first studied in 1986 and is known as the Gordon–Haus jitter.
- Spontaneous emission affects the phase and changes signal frequency by a small but random amount.
- Group velocity depends on frequency because of dispersion.
- Speed at which pulse propagates through the fiber is affected by each amplifier in a random fashion.
- Such random speed changes produce random shifts in the pulse position at the receiver and leads to timing jitter.



Back

Close

Dispersion Management

- Standard fibers have large dispersion near $1.55 \mu\text{m}$.
- Transmission distance limited to $L < (16|\beta_2|B^2)^{-1}$ even when DFB lasers are used.
- $L < 35 \text{ km}$ at $B = 10 \text{ Gb/s}$ for standard fibers with $|\beta_2| \approx 21 \text{ ps}^2/\text{km}$.
- Operation near the zero-dispersion wavelength not realistic for WDM systems because of the onset of four-wave mixing.
- Dispersion must be managed using a suitable technique.

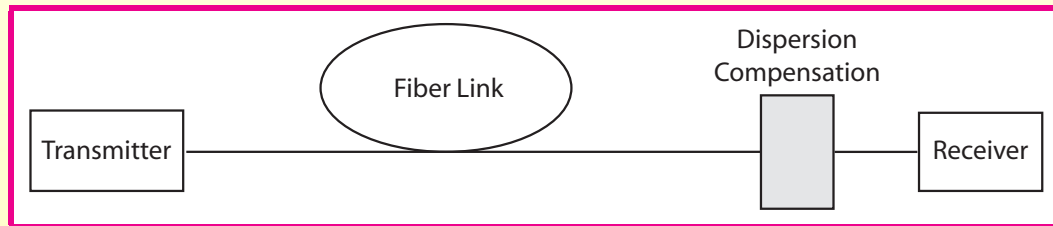



Basic Idea

- Pulse propagation in the linear case governed by

$$\frac{\partial A}{\partial z} + \frac{i\beta_2}{2} \frac{\partial^2 A}{\partial t^2} = 0.$$

- Using the Fourier-transform method, the solution is

$$A(z, t) = \frac{1}{2\pi} \int_{-\infty}^{\infty} \tilde{A}(0, \omega) \exp\left(\frac{i}{2}\beta_2 z \omega^2 - i\omega t\right) d\omega.$$

- Phase factor $\exp(i\beta_2 z \omega^2 / 2)$ is the source of degradation.
- A dispersion-management scheme cancels this phase factor.
- Actual implementation can be carried out at the transmitter, at the receiver, or along the fiber link.
- Such a scheme works only if nonlinear effects are negligible.



Back

Close

Dispersion Management Schemes

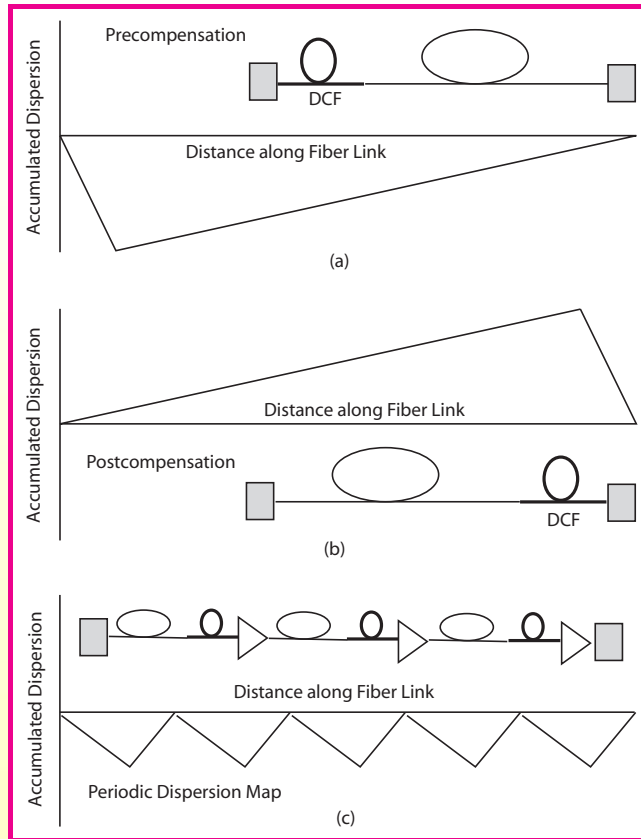



Dispersion-Compensating Fibers

- Fibers with opposite dispersion characteristics used.
- *Two-section map*: $D_1L_1 + D_2L_2 = 0$.
- Special dispersion-compensating fibers (DCFs) developed with $D_2 \sim -100$ ps/(nm-km).
- Required length $L_2 = -D_1L_1/D_2$ (typically 5-10 km).
- DCF modules inserted periodically along the link.
- Each module introduces 5–6 dB losses whose compensation increases the noise level.
- A relatively small core diameter of DCFs leads to enhancement of nonlinear effects.



Two-Mode DCFs

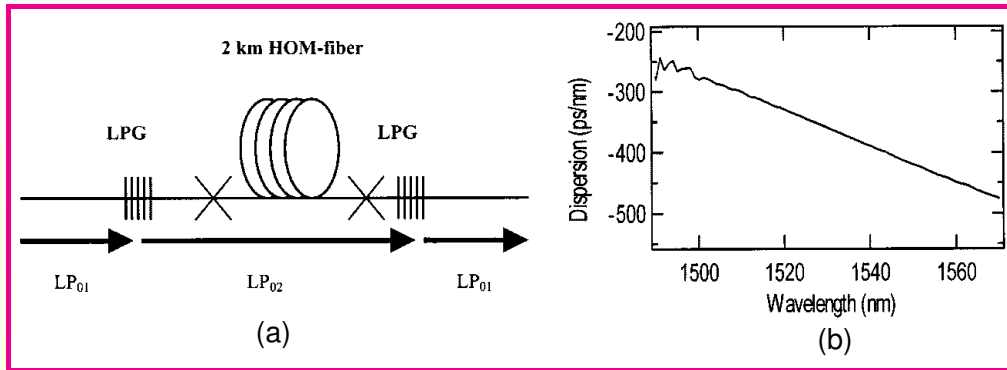

- A new type of DCF uses a *two-mode fiber* ($V > 2.405$).
- Long-period fiber gratings transfer power from one mode to another.
- Dispersion for the higher-order mode can be as large as $-500 \text{ ps}/(\text{km}\cdot\text{nm})$.
- Low insertion losses and a large mode area of such DCFs make them quite attractive.



Photonic-Crystal Fibers

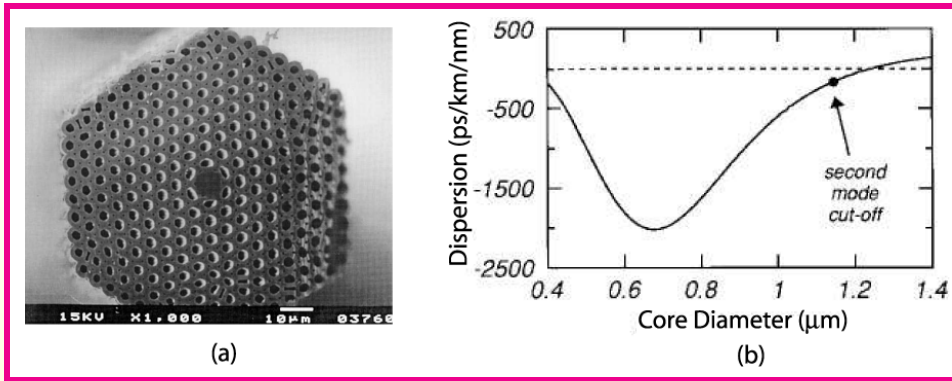

- A new approach to DCF design makes use of photonic-crystal (or microstructure) fibers.
- Such fibers contain a two-dimensional array of air holes around a central core.
- Holes modify dispersion characteristics substantially.
- Values of D as large as $-2000 \text{ ps}/(\text{km}\cdot\text{nm})$ are possible over a narrower bandwidth.



Optical Phase Conjugation

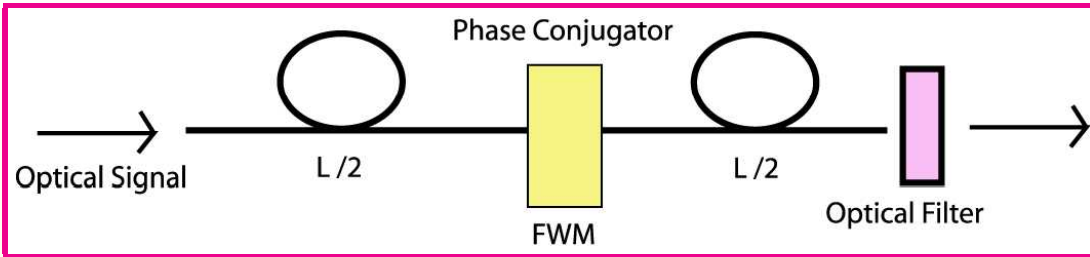

- Four-wave mixing used to generate phase-conjugated field in the middle of fiber link.
- β_2 reversed for the phase-conjugated field:

$$\frac{\partial A}{\partial z} + \frac{i\beta_2}{2} \frac{\partial^2 A}{\partial t^2} = 0 \quad \rightarrow \quad \frac{\partial A^*}{\partial z} - \frac{i\beta_2}{2} \frac{\partial^2 A^*}{\partial t^2} = 0.$$

- Pulse shape restored at the fiber end.
- Basic idea patented in 1979.
- First experimental demonstration in 1993.





Management of Nonlinear Effects

- Reduce launch power as much as possible. But, amplifier noise forces certain minimum power to maintain the SNR.
- Pseudo-linear Systems employ short pulses that spread rapidly.
- Resulting decrease in peak power reduces nonlinear effects.
- Overlapping of pulses leads to intrachannel nonlinear effects.
- Another solution: Propagate pulses as solitons by launching an optimum amount of power.
- Manage loss and dispersion: Dispersion-Managed Solitons are used in practice.



Back

Close



Fiber Solitons

- Combination of SPM and anomalous GVD required.
- GVD broadens optical pulses except when the pulse is initially chirped such that $\beta_2 C < 0$.
- SPM imposes a chirp on the optical pulse such that $C > 0$.
- Soliton formation possible only when $\beta_2 < 0$.
- SPM-induced chirp is power dependent.
- SPM and GVD can cooperate when input power is adjusted such that SPM-induced chirp just cancels GVD-induced broadening.
- Nonlinear Schrödinger Equation governs soliton formation

$$i \frac{\partial A}{\partial z} - \frac{\beta_2}{2} \frac{\partial^2 A}{\partial t^2} + \gamma |A|^2 A = 0.$$



Bright Solitons

- Normalized variables: $\xi = z/L_D$, $\tau = t/T_0$, and $U = A/\sqrt{P_0}$

$$i \frac{\partial U}{\partial \xi} \pm \frac{1}{2} \frac{\partial^2 U}{\partial \tau^2} + N^2 |U|^2 U = 0.$$

- Solution depends on a single parameter N defined as

$$N^2 = \frac{L_D}{L_{NL}} = \frac{\gamma P_0 T_0^2}{|\beta_2|}.$$

- Dispersion and nonlinear lengths:
 $L_D = T_0^2/|\beta_2|$, $L_{NL} = 1/(\gamma P_0)$.
- The two are balanced when $L_{NL} = L_D$ or $N = 1$.
- NLS equation can be solved exactly with the inverse scattering method.



44/66



Back

Close

Pulse Evolution

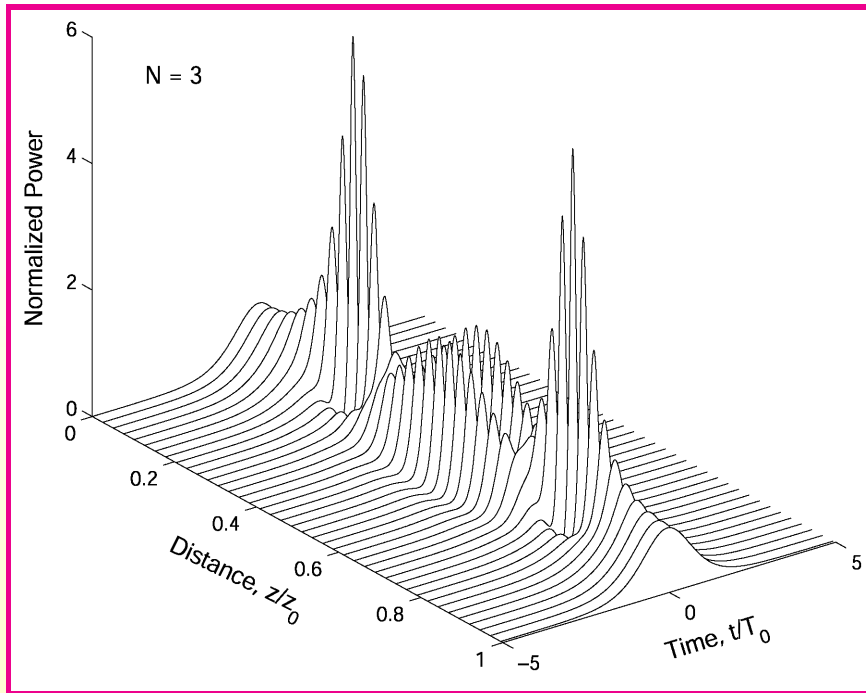

- Periodic evolution for a third-order soliton ($N = 3$).
- When $N = 1$, solitons preserve their shape.



45/66



Back

Close



Fundamental Soliton Solution

- For fundamental solitons, NLS equation becomes

$$i \frac{\partial u}{\partial \xi} + \frac{1}{2} \frac{\partial^2 u}{\partial \tau^2} + |u|^2 u = 0.$$

- If $u(\xi, \tau) = V(\tau) \exp[i\phi(\xi)]$, V satisfies $\frac{d^2 V}{d\tau^2} = 2V(K - V^2)$.
- Multiplying by $2(dV/d\tau)$ and integrating over τ

$$(dV/d\tau)^2 = 2KV^2 - V^4 + C.$$

- $C = 0$ from the boundary condition $V \rightarrow 0$ as $|\tau| \rightarrow \infty$.
- Constant $K = \frac{1}{2}$ using $V = 1$ and $dV/d\tau = 0$ at $\tau = 0$.
- Final Solution: $u(\xi, \tau) = \text{sech}(\tau) \exp(i\xi/2)$.



Back

Close

Stability of Fundamental Solitons

- Very stable; can be excited using any pulse shape.
- Evolution of a Gaussian pulse with $N = 1$:

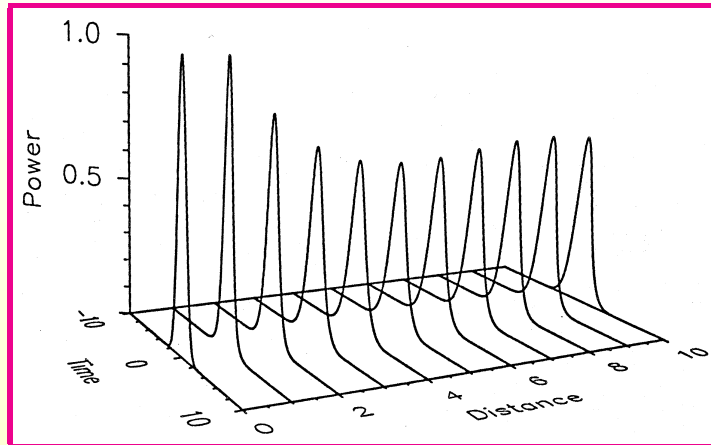

- Nonlinear index $\Delta n = n_2 I(t)$ larger near the pulse center.
- Temporal mode of a SPM-induced waveguide.



47/66



Back

Close



Loss-Managed Solitons

- Fiber losses destroy the balance needed for solitons.
- Soliton energy and peak power decrease along the fiber.
- Nonlinear effects become weaker and cannot balance dispersion completely.
- Pulse width begins to increase along the fiber.
- Solution: Compensate losses periodically using amplifiers.
- Solitons sustained through periodic amplification are called **loss-managed solitons**.
- They need to be launched with a higher energy.



Soliton Amplification

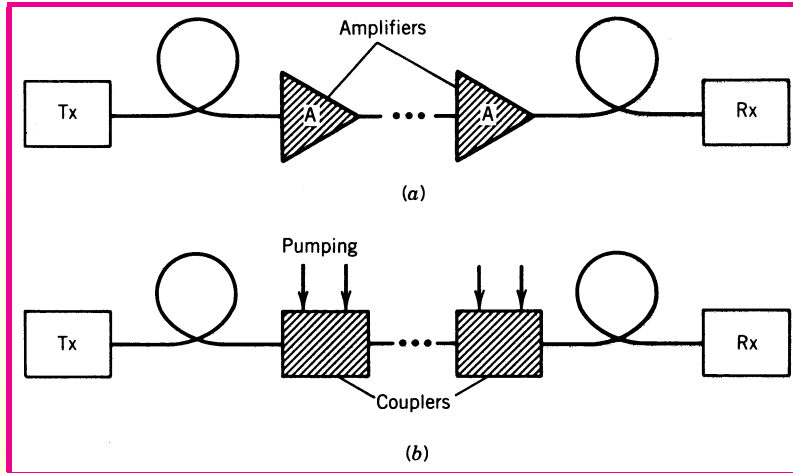

- Optical amplification necessary for long-haul systems.
- System design identical to non-soliton systems.
- Lumped amplifiers placed **periodically along the link**.
- **Distributed Raman amplification** is a better alternative.



Dispersion-Managed solitons

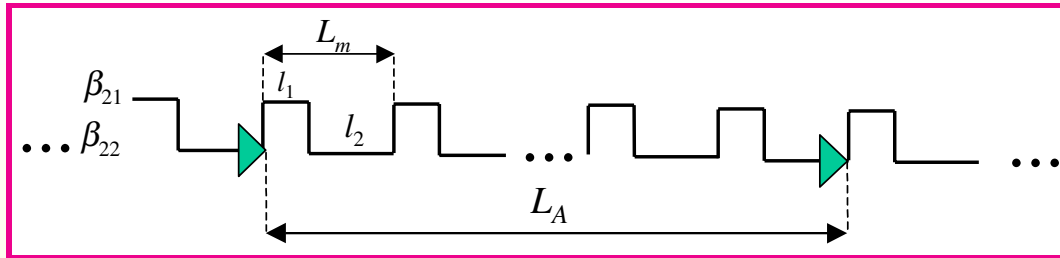

Nonlinear Schrödinger Equation

$$i \frac{\partial B}{\partial z} - \frac{\beta_2(z)}{2} \frac{\partial^2 B}{\partial t^2} + \gamma p(z) |B|^2 B = 0.$$

- $\beta_2(z)$ is a periodic function with period L_{map} .
- $p(z)$ accounts for loss-induced power variations.
- $L_A = mL_{\text{map}}$, where m is an integer.
- Often $L_A = L_D$ ($m = 1$) in practice.
- DM solitons are solutions of the modified NLS equation.



Pulse Width and Chirp Evolution

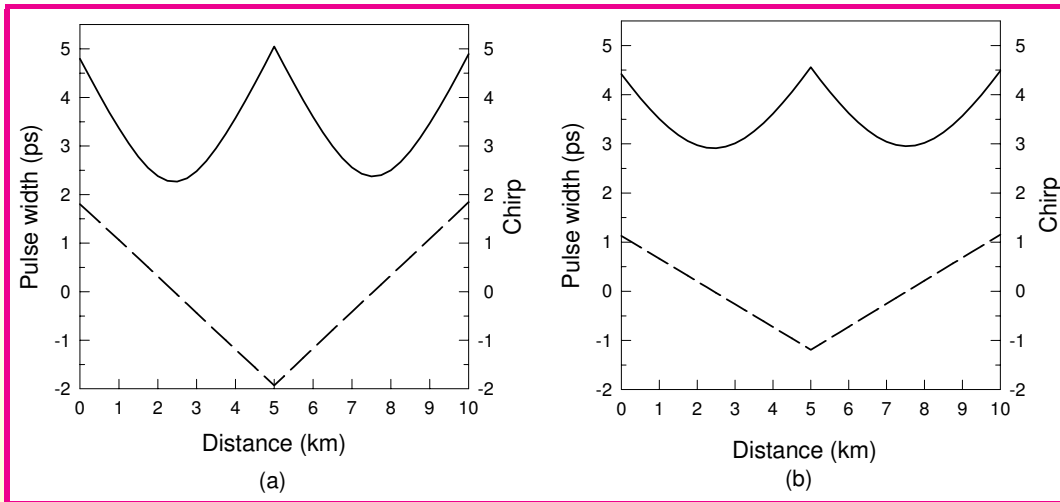

- Pulse width and chirp of DM solitons for two pulse energies.
- Pulse width minimum where chirp vanishes.
- Shortest pulse occurs in the middle of anomalous-GVD section.
- DM soliton does not maintain its chirp, width, or peak power.



WDM Systems

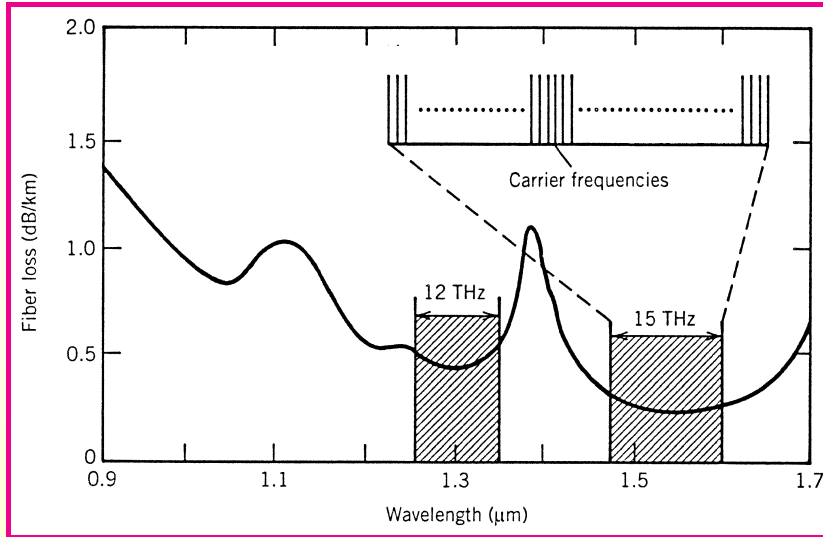

- Optical fibers offer a huge bandwidth (~ 100 THz).
- Single-channel bit rate limited to 40 Gb/s by electronics.
- Solution: Wavelength-division multiplexing (WDM).
- Many 10 or 40-Gb/s channels sent over the same fiber.



Point-to-Point WDM Links

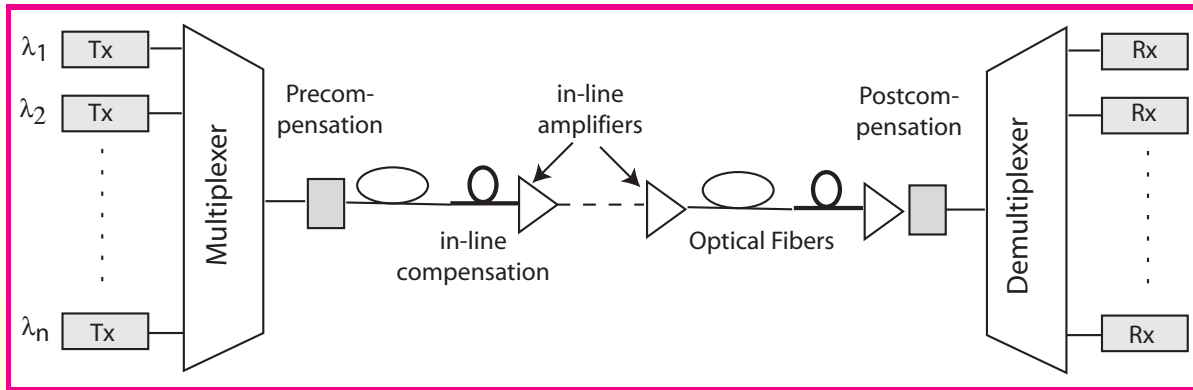

- Bit streams from several transmitters are multiplexed together.
- A demultiplexer separates channels and feeds them into individual receivers.
- Channel spacing in the range 25–100 GHz.
- ITU grid specifies source wavelengths from 1530 to 1610 nm.



High-capacity Experiments



54/66

Channels N	Bit Rate B (Gb/s)	Capacity NB (Tb/s)	Distance L (km)	NBL Product [(Pb/s)-km]
120	20	2.40	6200	14.88
132	20	2.64	120	0.317
160	20	3.20	1500	4.80
82	40	3.28	300	0.984
256	40	10.24	100	1.024
273	40	10.92	117	1.278

- Capacity increased using C and L bands simultaneously.
C band = 1525–1565 nm; L band = 1570–1610 nm.
- Other bands defined to cover 1.3–1.6 μm range.
- Total fiber capacity exceeds 30 Tb/s.



Back

Close



Crosstalk in WDM Systems

- System performance degrades whenever power from one channel leaks into another.
- Such a power transfer can occur because of the nonlinear effects in optical fibers (nonlinear crosstalk).
- Crosstalk occurs even in a perfectly linear channel because of imperfections in WDM components.
- **Linear crosstalk** can be classified into two categories.
- **Heterowavelength or Out-of-band crosstalk**: Leaked power is at a different wavelength from the channel wavelength.
- **Homowavelength or In-band crosstalk**: Leaked power is at the same wavelength as the channel wavelength.



Back

Close



Nonlinear Raman Crosstalk

- SRS not of concern for single-channel systems because of its high threshold (about 500 mW).
- In the case of WDM systems, fiber acts as a Raman amplifier.
- Long-wavelength channels amplified by short-wavelength channels.
- Power transfer depends on the bit pattern: amplification occurs only when 1 bits are present in both channels simultaneously.
- SRS induces power fluctuations (noise) in all channels.
- Shortest-wavelength channel most depleted.
- One can estimate Raman crosstalk from the depletion and noise level of this channel.





Four-Wave Mixing

- FWM generates new waves at frequencies $\omega_{ijk} = \omega_i + \omega_j - \omega_k$.
- In the case of equally spaced channels, new frequencies coincide with the existing frequencies and produce in-band crosstalk.
- Coherent crosstalk is unacceptable for WDM systems.
- In the case of nonuniform channel spacing, most FWM components fall in between the channels and produce out-of-band crosstalk.
- Nonuniform channel spacing not practical because many WDM components require equal channel spacings.
- A practical solution offered by the periodic dispersion management technique.
- GVD high locally but its average value is kept low.



Cross-Phase Modulation

- XPM-induced phase shift depends on bit pattern of channels.
- Dispersion converts pattern-dependent phase shifts into power fluctuations (noise).
- Level of fluctuations depends on channel spacing and local GVD.
- Fluctuations as a function of channel spacing for a 200-km link.

Thiele et al, PTL **12**, 726, 2000

- No dispersion management
- With dispersion management
- ▽ Field conditions

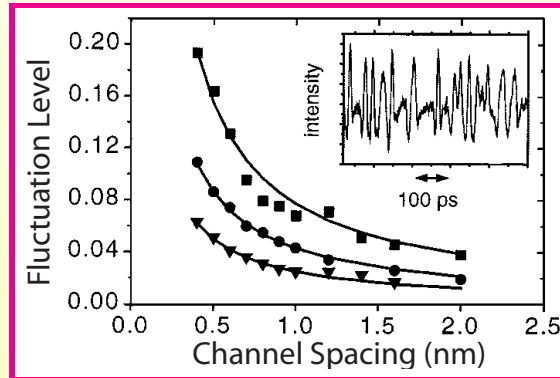

58/66



Back

Close



Control of Nonlinear Effects

- SPM, XPM, and FWM constitute the dominant sources of power penalty for WDM systems.
- FWM can be reduced with dispersion management.
- modern WDM systems are limited by the XPM effects.
- Several techniques can be used for reducing the impact of nonlinear effects.
 - ★ Optimization of Dispersion Maps
 - ★ Use of Raman amplification
 - ★ Polarization interleaving of channels
 - ★ Use of CSRZ, DPSK, or other formats



Back

Close

Prechirping of Pulses

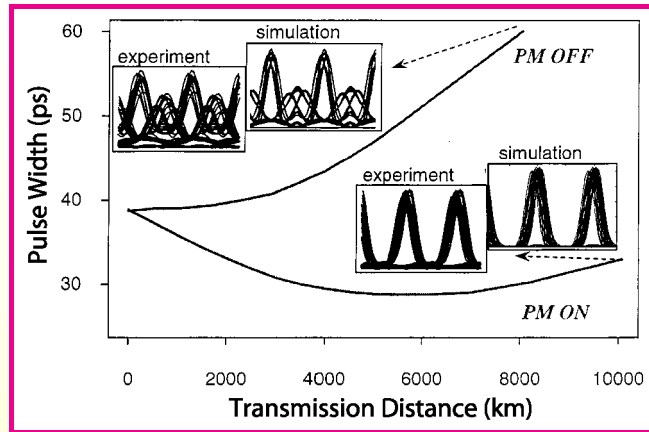

- Use of CRZ format (Golovchenko et al., JSTQE **6**, 337, 2000); 16 channels at 10 Gb/s with 100-GHz channel spacing.
- A phase modulator was used for prechirping pulses.
- Considerable improvement observed with phase modulation (PM).
- A suitably chirped pulse undergoes a compression phase.



Mid-Span Spectral Inversion

Woods et al., PTL **16**, 677, (2004)

Left: No phase conjugation

Right: With phase conjugation

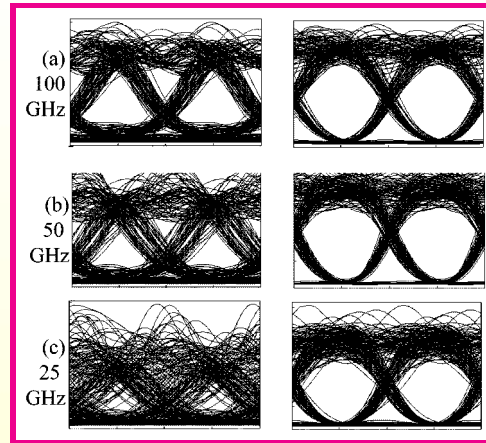

- Simulated eye patterns at 2560 km for 10-Gbs/s channels.
- A phase conjugator placed in the middle of fiber link.
- XPM effects nearly vanish as dispersion map appears symmetric,
- XPM-induced frequency shifts accumulated over first half are cancelled in the second-half of the link.



Distributed Raman Amplification

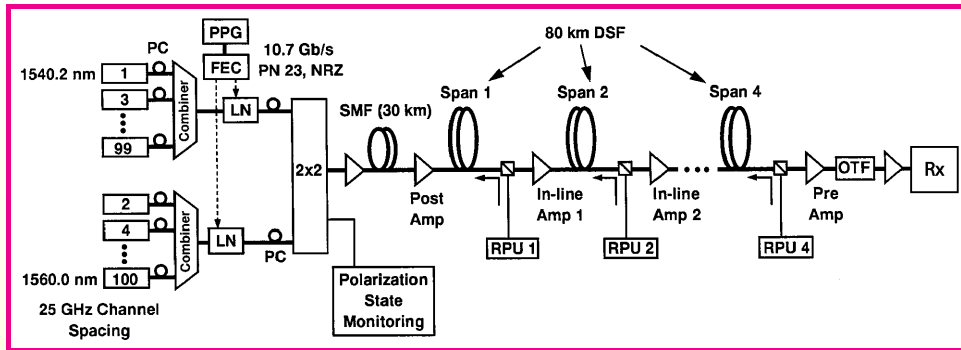

- Use of Raman amplification for reducing nonlinear effects.
- Distributed amplification lowers accumulated noise.
- Same value of Q factor obtained at lower launch powers.
- Lower launch power reduces all nonlinear effects in a WDM system.
- In a 2004 experiment, 64 channels at 40 Gb/s transmitted over over 1600 km (Grosz et al., PTL **16**, 1187, 2004).





Polarization Interleaving of Channels

- Neighboring channels of a WDM system are orthogonally polarized.
- XPM coupling depends on states of polarization of interacting channels and is reduced for orthogonally polarized channels.

$$\delta n = n_2(P_1 + 2P_2) \implies \delta n = n_2(P_1 + \frac{2}{3}P_2).$$

- Both amplitude and timing jitter are reduced considerably.
- PMD reduces the effectiveness of this technique.
- Polarization-interleaving technique helpful when fibers with low PMD are employed and channel spacing is kept < 100 GHz.
- This technique is employed often in practice.



Use of DPSK Format

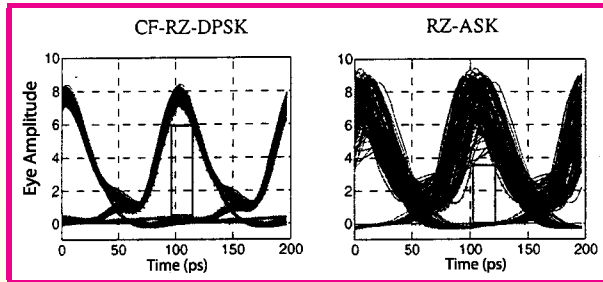

- Eye diagrams at 3000 km for 10-Gb/s channels with 100-GHz spacing (Leibrich et al., PTL **14**, 155 2002).
- XPM is harmful because of randomness of bit patterns.
- In a RZ-DPSK system, information is coded in pulse phase.
- Since a pulse is present in all bit slots, channel powers vary in a periodic fashion.
- Since all bits are shifted in time by the same amount, little timing jitter is induced by XPM.





Concluding Remarks

- Optical amplifiers have solved the fiber-loss problem.
- Dispersion management solves the dispersion problem and also reduces FWM among WDM channels.
- Nonlinear effects, PMD, and amplifier noise constitute the major limiting factors of modern systems.

Research Directions

- Extend the system capacity by opening new transmission bands (L, S, S+, etc.)
- Develop new fibers with low loss and dispersion over the entire 1300–1650 nm wavelength range.
- Improve spectral efficiency (New formats: DPSK, DQPSK, etc.)



Back

Close



Bibliography

- G. P. Agrawal, [Fiber-Optic Communication Systems](#), 3rd ed. (Wiley, Hoboken, NJ, 2002)
- R. Ramaswami and K. Sivarajan, [Optical Networks](#) 2nd ed. (Morgan, San Francisco, 2002).
- G. E. Keiser, [Optical Fiber Communications](#), 3rd ed. (McGraw-Hill, New York, 2000).
- G. P. Agrawal, [Lightwave Technology: Components and Devices](#) (Wiley, Hoboken, NJ, 2004).
- G. P. Agrawal, [Lightwave Technology: Telecommunication Systems](#) (Wiley, Hoboken, NJ, 2005).

