

OptiFDTD

Technical Background and Tutorials

Finite Difference Time Domain Photonics Simulation Software

Version 10.0
for Windows® XP/Vista/Windows 7™ 32/64 bit
& Linux 64-bit for 3D simulations



OptiFDTD

Technical Background and Tutorials

Finite Difference Time Domain Photonics Simulation Software

Copyright © 2011 Optiwave

All rights reserved.

All OptiFDTD documents, including this one, and the information contained therein, is copyright material.

No part of this document may be reproduced, stored in a retrieval system, or transmitted in any form or by any means whatsoever, including recording, photocopying, or faxing, without prior written approval of Optiwave.

Disclaimer

Optiwave makes no representation or warranty with respect to the adequacy of this documentation or the programs which it describes for any particular purpose or with respect to its adequacy to produce any particular result. In no event shall Optiwave, its employees, its contractors or the authors of this documentation, be liable for special, direct, indirect, or consequential damages, losses, costs, charges, claims, demands, or claim for lost profits, fees, or expenses of any nature or kind.

Technical support

If you purchased Optiwave software from a distributor that is not listed here, please send technical questions to your distributor.

Optiwave Systems Inc.

Canada/US East

Tel (613) 224-4700

E-mail support@optiwave.com

Fax (613) 224-4706

URL www.optiwave.com

Cybernet Systems Co., Ltd.

Japan

Tel +81 (03) 5978-5414

E-mail owtech@cybernet.co.jp

Fax +81 (03) 5978-6082

URL www.cybernet.co.jp

Optiwave Europe

Europe

Tel +33 (0) 494 08 27 97

E-mail support@optiwave.com

Fax +33 (0) 494 33 65 76

URL www.optiwave.eu

Table of Contents

Table of Contents.....	1
Installing OptiFDTD	1
Hardware and software requirements.....	1
Protection key	1
OptiFDTD directory	2
Installation	2
FDTD Basics.....	3
2D FDTD Equations.....	3
TE waves.....	4
TM waves	7
3D FDTD Equations.....	8
Output data	13
Material Models	15
Constant Dielectrics.....	15
Lossy dielectrics	16
Lorentz dispersion materials.....	17
Drude Model	18
Nonlinear material model.....	19
Lorentz-Drude Model.....	24
References:.....	27
OptiFDTD Boundary Conditions.....	29
PML Boundary Conditions	29
PMC/PEC boundary conditions and plane wave simulation.....	30
Image value of PEC/ PMC.....	30
Plane wave realized in symmetric/periodic structure.....	32
PBC Boundary Conditions	34
Input Wave.....	35
Incident wave source excitation — Total/Reflected field formulation.....	35
CW excitation	36
Pulsed excitation	36

Point Source	36
Gaussian Beam Size	37
2D Total Field /Scattering Field (TF/SF) region.....	38
2D FDTD Band Solver	40
Simulation concept introduction.....	40
Bloch's boundary condition.....	41
Initial excitation	42
Unit cell and Brillouin zone	43
References:.....	44
Post-simulation Data Analysis	45
Discretized Fourier Transform (DFT) and Fast Fourier Transform (FFT)	45
Power calculation and Poynting vector	45
Overlap Integral (OI)	46
Mode Overlap Integral (MOI)	46
Input Overlap Integral (IOI).....	46
Input Overlap Integral Scan (IOIS)	47
Far Field Transform	47
Fraunhofer approximation	47
Fresnel-Kirchhoff Diffraction Formula.....	48
Heating Absorption	49
RCS Calculation	50
References:.....	52
Plane Wave Expansion (PWE) method	53
References:.....	54
Power Transmittance Calculation with VB Scripting	55
References:.....	56
FDTD basic references	56
Material models	56
Anisotropic Perfectly Matched Layer (Anisotropic PML) boundary conditions	56
Nonlinearity	56
Tutorials.....	59
Introduction to the layout designer concept.....	61

Know the difference between 32-bit and 64-bit simulations.....	87
Lesson 1—Getting started	91
Create a new project	93
Create a design	102
Set up the Input Plane	109
Observe the Refractive Index Distribution	118
Set up observation points, areas, and lines	120
Run the simulation.....	124
Analyze the simulation results	133
Export results	147
Lesson 2—Input wave setup.....	149
Point Source	163
Lesson 3—Photonic crystal and photonic band gap simulation	167
Sample 1---PGB Layout	167
Sample 2---Plane wave simulation based on the periodic cell of PhC.....	187
Sample 3---Periodic Boundary Condition for PBG simulation	197
Lesson 4—Multiple resonant Lorentz dispersive material simulation ...	201
Lesson 5—Drude model for noble metal and surface plasma simulation ...	213
Lesson 6—2nd-Order nonlinearity simulation	223
2nd Order nonlinear material simulation.....	223
Lesson 7—Four wave mixing	241
Lesson 8—Plane wave simulation	255
2D-TE plane wave in unique material.....	255
3D-Y-direction polarized plane wave in unique material.....	260
Lesson 9—FDTD Band Solver	263
Photonic crystal structure	263
Band Solver parameters.....	268

**Lesson 10 - Lorentz_Drude model for metal and surface plasma simulation
273**

Lesson 11 - Analyzing 1D Photonic Crystals (Bragg gratings) 287

Introduction	287
Define the Lattice Structure	287
PWE Band Solver Parameters	292
Run Simulation and View Results	294
Bragg grating with layers of different width.....	295
Off-axis propagation	296
References:.....	297

Lesson 12 - Analyzing 2D Photonic Crystals 299

Introduction	299
References:.....	306

Lesson 13 - Analyzing 3D Photonic Crystals 307

Introduction	307
1. FCC lattices of Air Spheres in Dielectric.....	307
2. Diamond Lattice of Air Spheres in Dielectric	312
References:.....	314

Lesson 14 - Analyzing 2D Defects in Photonic Crystals..... 315

Introduction	315
1. Square 2D lattice	315
References:.....	321

Lesson 15 - Grating Simulation 323

Part 1 --- Simulations of Gratings Created with VB Script	323
Introduce the layout	323
Part 2 --- Calculate the transmission and reflection spectrum from grating unit cell	330
Part 3 --- Calculate the diffraction efficiency and diffraction angle based on grat- ing unit cell simulation	333

**Lesson 16 – Calculating Power Transmittance and Reflection using VB
Script..... 341**

Lesson 17 - Analysis of Photonic Crystal Fibers (PCF) in OptiFDTD	345
Introduction	345
Sample 1- Photonic Crystal Fiber-Holey Fiber	346
Create the layout	347
Convert Refractive index distribution to a file	357
Perform the Modal analysis	358
Perform the wavelength scanning mode analysis.....	361
Lesson 18 - Simulations with 64-bit 3D Simulator	365
Create a new Layout	366
Layout creation steps	366
Define Input Wave	369
Define Simulation Parameters	371
Observe the Refractive Index	373
Setup the Observation Objects (result data-detector)	375
Perform the 64Bit-FDTD FDTD Simulation.....	378
Post-Simulation Data Analysis	381
Observation Point	381
Field pattern in Observation Area	384
Power transmission/reflection function	387
Lesson 19 - Heating absorption simulation using 64bit processor	389
Define Input Wave	395
Define Simulation Parameters	397
Observe the Refractive Index (Optional)	400
Setup the Observation Objects (result data detector).....	401
Perform the 64Bit-FDTD FDTD Simulation.....	403
Post-Simulation Data Analysis	404
Lesson 20 - 2D Total Field/Scattering Field(TF/SF) simulation and Radar Cross Section(RCS) Detection	407
Layout creation steps	407
Define Input Wave	409
Define Simulation Parameters	414
Perform the 32Bit-FDTD FDTD Simulation.....	415
Observe Steady state response in Analyzer	416
RCS calculation for an infinity cylinder	417
Reference:.....	421

Lesson 21 - Simulation on 3D surface Plasmon based layout	423
Example 1 nano-gold particle simulation	423
Layout Creation steps.....	423
Define Input Wave	426
Define Simulation Parameters	427
Setup the Observation Objects (result data-detector).....	428
Perform the 64Bit-FDTD Simulation	429
Post-Simulation Data Analysis	430
Example 2 Simulate Sub wavelength holes in metallic film.....	432
Layout Creation steps.....	432
Design VB script code to Scan the hole width	437
Define Input Wave	438
Define Simulation Parameters	439
Setup the Observation Objects (result data-detector)	439
Perform the VB scripting Scanning 64Bit-FDTD Simulation	441
Post-Simulation Data Analysis	441
Lesson 22 - Simulation 3D layout using non-uniform mesh	443
Check the memory requirement	444
Non-uniform mesh setting	445
Perform the 64bit simulation and post data analysis	448
Using the user defined non-uniform mesh.....	449

Installing OptiFDTD

Before installing OptiFDTD, ensure the system requirements described below are available.

Hardware and software requirements

OptiFDTD requires the following minimum system configuration:

- Microsoft Windows XP/Vista/7, 32-bit or 64-bit, note: 64-bit OS is required to run 64-bit simulators
- Personal computer with Pentium 4 or higher processor 1.2 GHz (or higher). Multi-core CPU is required for increased performance of parallel processing simulators.
- 2GB of RAM or higher (dependent on the size of calculated problem)
- 500 MB to 10 GB free hard drive disk space depending on calculation size for storage of the simulation results
- 1024 x 768 graphic resolution, minimum 256 colors
- Internet Explorer 5.5 (or higher)
- Most recent video and OpenGL drivers for your graphics card

Note: For machines running Windows XP, the “Windows Classic” theme must be used.

Protection key

A hardware protection key is supplied with the software. To ensure that OptiFDTD operates properly, verify the following:

- The protection key is properly connected to the parallel port of the computer.
- If you use more than one protection key, ensure that there is no conflict between the OptiFDTD protection key and the other keys.

Note: Use a switch box to prevent protection key conflicts. Ensure that the cable between the switch box and the computer is a maximum of one meter long.

OptiFDTD directory

By default, the OptiFDTD installer creates an OptiFDTD directory on your hard disk. The OptiFDTD directory contains the following subdirectories:

- **\BIN** – contains executable files, dynamic linked libraries, and help files
- **\SAMPLES** – contains OptiFDTD examples
- **\TMP** – temporary directory used by OptiFDTD during operation
- **\DOC** – OptiFDTD support documentation

Installation

- OptiFDTD can be installed on Windows XP/Vista/7, 32-bit or 64-bit, note: 64-bit OS is required to run 64-bit simulators.
- Linux 64-bit for 3D simulations, Linux enabled versions only (see the Release Notes for more information).
- We recommend that you exit all Windows programs before running the setup program.

Installing OptiFDTD on Windows operating systems

To install OptiFDTD on Windows operating systems, perform the following procedure.

- | Step | Action |
|-------------|---|
| 1 | Log on as the Administrator, or log onto an account with Administrator privileges. |
| 2 | Insert the OptiFDTD installation CD into your CD ROM drive. |
| 3 | On the Taskbar, click Start and select Run .
<i>The Run dialog box appears.</i> |
| 4 | In the Run dialog box, type F:\setup.exe , where F is your CD ROM drive. |
| 5 | Click OK and follow the screen instructions and prompts. |
| 6 | When the installation is complete, remove the CD from the CD ROM drive and reboot your computer. |

FDTD Basics

OptiFDTD is a powerful, highly integrated, user-friendly software that allows computer aided design and simulation of advanced passive photonic components.

The OptiFDTD software package is based on the finite-difference time-domain (FDTD) method. The FDTD method has been established as a powerful engineering tool for integrated and diffractive optics device simulations. This is due to its unique combination of features, such as the ability to model light propagation, scattering and diffraction, and reflection and polarization effects. It can also model material anisotropy and dispersion without any pre-assumption of field behavior such as the slowly varying amplitude approximation. The method allows for the effective and powerful simulation and analysis of sub-micron devices with very fine structural details. A sub-micron scale implies a high degree of light confinement and correspondingly, the large refractive index difference of the materials (mostly semiconductors) to be used in a typical device design.

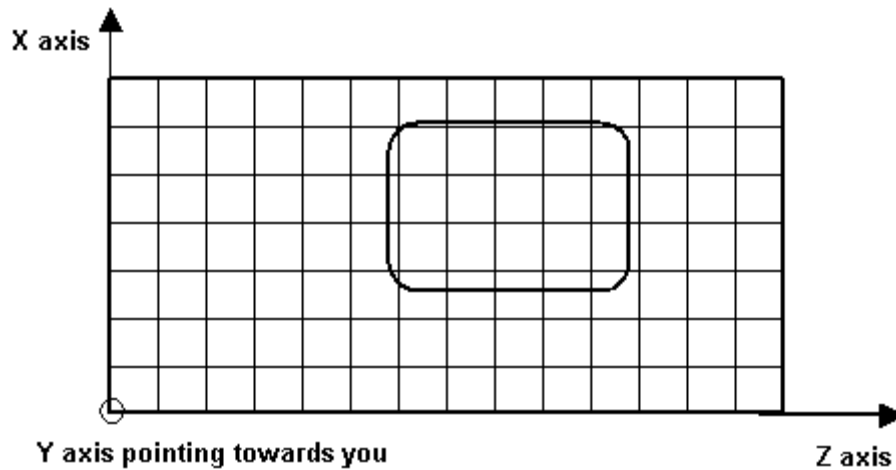
2D FDTD Equations

The FDTD approach is based on a direct numerical solution of the time-dependent Maxwell's curl equations. The first version of OptiFDTD is in 2D. The photonic device is laid out in the X-Z plane. The propagation is along Z. The Y-direction is assumed to be infinite. This assumption removes all the $\partial/\partial y$ derivatives from Maxwell's equations and splits them into two (TE and TM) independent sets of equations.

The 2D computational domain is shown in [Figure 1](#). The space steps in the X and Z directions are Δx and Δz , respectively. Each mesh point is associated with a specific

type of material and contains information about its properties such as refractive index, and dispersion parameters.

Figure 1 Numerical representation of the 2D computational domain



TE waves

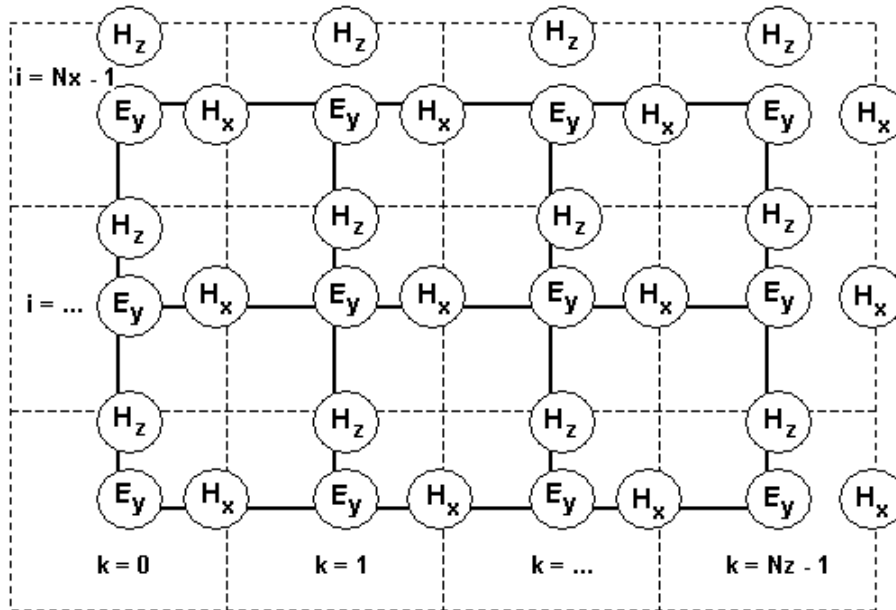
In the 2D TE case (H_x, E_y, H_z - nonzero components, propagation along Z, transverse field variations along X) in lossless media, Maxwell's equations take the following form:

$$\frac{\partial E_y}{\partial t} = \frac{1}{\epsilon} \left(\frac{\partial H_x}{\partial z} - \frac{\partial H_z}{\partial x} \right), \quad \frac{\partial H_x}{\partial t} = \frac{1}{\mu_0} \frac{\partial E_y}{\partial z}, \quad \frac{\partial H_z}{\partial t} = -\frac{1}{\mu_0} \frac{\partial E_y}{\partial x} \quad (1)$$

where $\epsilon = \epsilon_0 \epsilon_r$ is the dielectric permittivity and μ_0 is the magnetic permeability of the vacuum. The refractive index is $n = \sqrt{\epsilon_r}$.

Each field is represented by a 2D array — $E_y(i,k)$, $H_x(i,k)$ and $H_z(i,k)$ — corresponding to the 2D mesh grid given in [Figure 1](#). The indices i and k account for the number of space steps in the X and Z direction, respectively. In the case of TE, the location of the fields in the mesh is shown in [Figure 2](#).

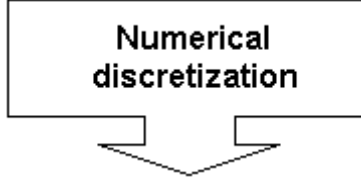
Figure 2 Location of the TE fields in the computational domain



The TE fields stencil can be explained as follows. The E_y field locations coincide with the mesh nodes given in Figure 1. In Figure 2, the solid lines represent the mesh given in Figure 1. The E_y field is considered to be the center of the FDTD space cell. The dashed lines form the FDTD cells. The magnetic fields H_x and H_z are associated with cell edges. The locations of the electric fields are associated with integer values of the indices i and k . The H_x field is associated with integer i and $(k + 0.5)$ indices. The H_z field is associated with $(i + 0.5)$ and integer k indices. The numerical analog in Equation 1 can be derived from the following relation:

$$\frac{\partial E_y}{\partial t} = \frac{1}{\epsilon} \left(\frac{\partial H_x}{\partial z} - \frac{\partial H_z}{\partial x} \right) \quad (2)$$

:



$$\frac{E_y^n(i,k) - E_y^{n-1}(i,k)}{\Delta t} = + \frac{1}{\varepsilon} \frac{H_x^{n-1/2}(i,k+1/2) - H_x^{n-1/2}(i,k-1/2)}{\Delta z} - \frac{1}{\varepsilon} \frac{H_z^{n-1/2}(i+1/2,k) - H_z^{n-1/2}(i-1/2,k)}{\Delta x}$$

The total set of numerical Equation 1 takes the form:

$$E_y^n(i,k) = E_y^{n-1}(i,k) + \frac{\Delta t}{\varepsilon \Delta z} [H_x^{n-1/2}(i,k+1/2) - H_x^{n-1/2}(i,k-1/2)] - \frac{\Delta t}{\varepsilon \Delta x} [H_z^{n-1/2}(i+1/2,k) - H_z^{n-1/2}(i-1/2,k)]$$

$$H_x^{n+1/2}(i,k+1/2) = H_x^{n-1/2}(i,k+1/2) + \frac{\Delta t}{\mu_0 \Delta z} [E_y^n(i,k+1) - E_y^n(i,k)] \quad (3)$$

$$H_z^{n+1/2}(i+1/2,k) = H_z^{n-1/2}(i+1/2,k) - \frac{\Delta t}{\mu_0 \Delta x} [E_y^n(i+1,k) - E_y^n(i,k)]$$

The superscript n labels the time steps while the indices i and k label the space steps and Δx and Δz along the x and z directions, respectively. This is the so-called Yee's numerical scheme applied to the 2D TE case. It uses central difference approximations for the numerical derivatives in space and time, both having second-order accuracy. The sampling in space is on a sub-wavelength scale. Typically, 10 to 20 steps per wavelength are needed. The sampling in time is selected to ensure numerical stability of the algorithm. The time step is determined by the Courant limit:

$$\Delta t \leq 1 / (c \sqrt{1/(\Delta x)^2 + 1/(\Delta z)^2})$$

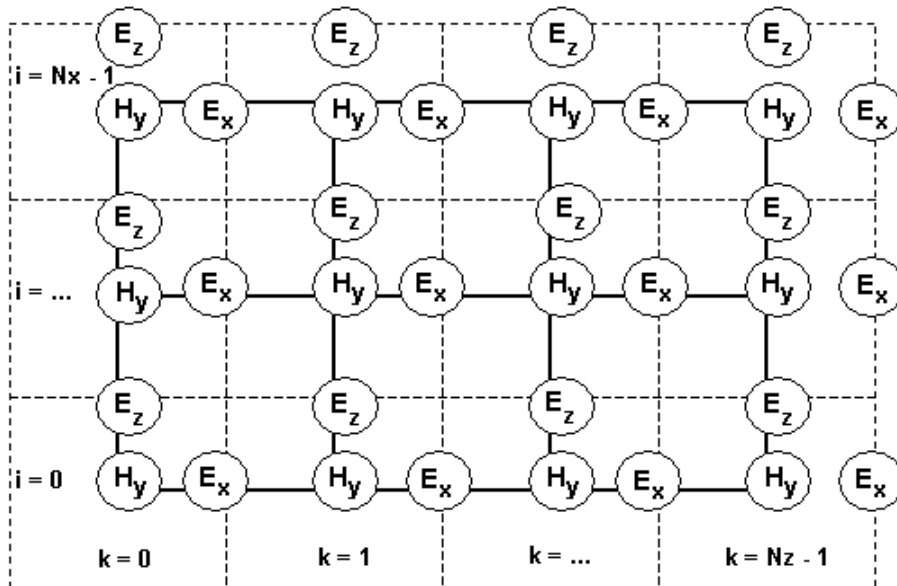
TM waves

In the 2D TM case (E_x, H_y, E_z — nonzero components, propagation along Z, transverse field variations along X) in lossless media, Maxwell's equations take the following form:

$$\frac{\partial H_y}{\partial t} = -\frac{1}{\mu_0} \left(\frac{\partial E_x}{\partial z} - \frac{\partial E_z}{\partial x} \right), \quad \frac{\partial E_x}{\partial t} = -\frac{1}{\varepsilon} \frac{\partial H_y}{\partial z}, \quad \frac{\partial E_z}{\partial t} = \frac{1}{\varepsilon} \frac{\partial H_y}{\partial x} \quad (4)$$

The location of the TM fields in the computational domain follows the same philosophy and is shown in [Figure 3](#).

Figure 3 Location of the TM fields in the computational domain shown in [Figure 112](#)



Now, the electric field components E_x and E_z are associated with the cell edges, while the magnetic field H_y is located at the cell center. The TM algorithm can be presented in a way similar to [Equation 3](#).

3D FDTD Equations

In 3D simulations, the simulation domain is a cubic box, the space steps are D_x , D_y , and D_z in x, y, and z directions respectively.

Each field components is presented by a 3D array --- $\mathbf{Ex}(i,j,k)$, $\mathbf{Ey}(i,j,k)$, $\mathbf{Ez}(i,j,k)$, $\mathbf{Hx}(i,j,k)$, $\mathbf{Hy}(i,j,k)$, $\mathbf{Hz}(i,j,k)$. The field components position in Yee's Cell are shown in Figure 4. These placements and the notation show that the E and H components are interleaved at intervals of $1/2Dh$ in space and $1/2Dt$ for the purpose of implementing a leapfrog algorithm.

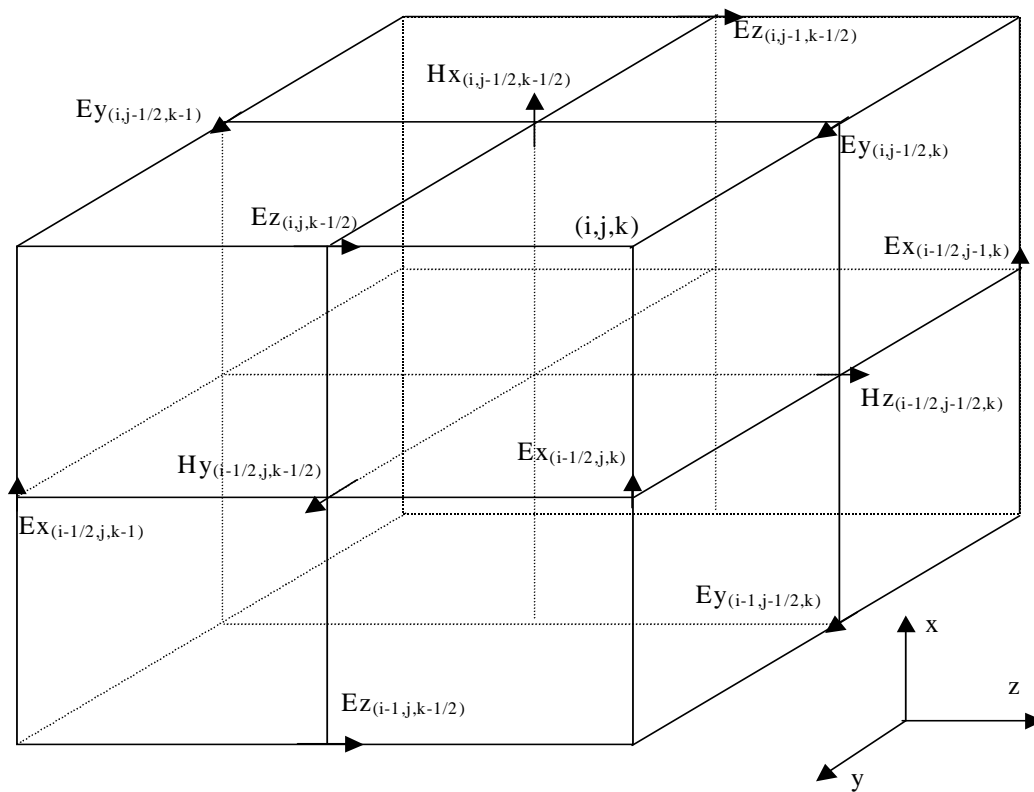


Figure 4 Displacement of the electric and magnetic field vector components about a cubic unit cell of the Yee space lattice

Now we can apply the above finite-difference ideas, notations, and field displacements to achieve a numerical approximation of Maxwell's equation (1.3-1.4).

The FDTD can be written as:

1.11a

$$H_{x,i,j-1/2,k-1/2}^{n+1/2} = H_{x,i,j-1/2,k-1/2}^{n-1/2} + \frac{\Delta t}{\mu_0 \Delta z} (E_{y,i,j-1/2,k}^n - E_{y,i,j-1/2,k-1}^n) - \frac{\Delta t}{\mu_0 \Delta y} (E_{z,i,j,k-1/2}^n - E_{z,i,j-1,k-1/2}^n)$$

1.11b

$$H_{y,i-1/2,j,k-1/2}^{n+1/2} = H_{y,i-1/2,j,k-1/2}^{n-1/2} + \frac{\Delta t}{\mu_0 \Delta x} (E_{z,i,j,k-1/2}^n - E_{z,i-1,j,k-1/2}^n) - \frac{\Delta t}{\mu_0 \Delta z} (E_{x,i-1/2,j,k}^n - E_{x,i-1/2,j,k-1}^n)$$

1.11c

$$H_{z,i-1/2,j-1/2,k}^{n+1/2} = H_{z,i-1/2,j-1/2,k}^{n-1/2} + \frac{\Delta t}{\mu_0 \Delta y} (E_{x,i-1/2,j,k}^n - E_{x,i-1/2,j-1,k}^n) - \frac{\Delta t}{\mu_0 \Delta x} (E_{y,i,j-1/2,k}^n - E_{y,i-1,j-1/2,k}^n)$$

1.12a

$$E_{x,i-1/2,j,k}^{n+1} = \frac{2\varepsilon - \sigma \Delta t}{2\varepsilon + \sigma \Delta t} E_{x-1/2,i,j,k}^n + \frac{2\Delta t}{(2\varepsilon + \sigma \Delta t) \Delta y} (H_{z,i-1/2,j+1/2,k}^{n+1/2} - H_{z,i-1/2,j-1/2,k}^{n+1/2}) - \frac{2\Delta t}{(2\varepsilon + \sigma \Delta t) \Delta z} (H_{y,i-1/2,j,k+1/2}^{n+1/2} - H_{y,i-1/2,j,k-1/2}^{n+1/2})$$

1.12b

$$E_{y,i,j-1/2,k}^{n+1} = \frac{2\varepsilon - \sigma \Delta t}{2\varepsilon + \sigma \Delta t} E_{y,i,j-1/2,k}^n + \frac{2\Delta t}{(2\varepsilon + \sigma \Delta t) \Delta z} (H_{x,i,j-1/2,k+1/2}^{n+1/2} - H_{x,i,j-1/2,k-1/2}^{n+1/2}) - \frac{2\Delta t}{(2\varepsilon + \sigma \Delta t) \Delta x} (H_{z,i+1/2,j-1/2,k}^{n+1/2} - H_{z,i-1/2,j-1/2,k}^{n+1/2})$$



1.12c

$$\begin{aligned}
 E_{z,i,j,k-1/2}^{n+1} &= \frac{2\varepsilon - \sigma\Delta t}{2\varepsilon + \sigma\Delta t} E_{z,i,j,k-1/2}^n \\
 &+ \frac{2\Delta t}{(2\varepsilon + \sigma\Delta t)\Delta x} (H_{y,i+1/2,j,k-1/2}^{n+1/2} - H_{y,i-1/2,j,k-1/2}^{n+1/2}) \\
 &- \frac{2\Delta t}{(2\varepsilon + \sigma\Delta t)\Delta y} (H_{x,i,j+1/2,k-1/2}^{n+1/2} - H_{x,i,j-1/2,k-1/2}^{n+1/2})
 \end{aligned}$$



Space Step and Time Step

The fundamental constraint of FDTD method is the step size both for the time and space. Space and time steps relate to the accuracy, numerical dispersion, and the stability of the FDTD method. Many references and books have discussed these problems. In general, to keep the results as accurate as possible, with a low numerical dispersive, the mesh size often quoted is "10 cells per wavelength", meaning that the side of each cell should be $1/10\lambda$ or less at the highest frequency (shortest wavelength).

Please note that FDTD is a volumetric computational method, so that if some portion of the computational space is filled with penetrable material, you must use the wavelength in the material to determine the maximum cell size.

The following equation is for the suggested mesh size:

1.15

$$\min(\Delta x, \Delta y, \Delta z) \leq \frac{\lambda_{\min}}{10n_{\max}}$$

where n_{\max} is the maximum refractive index value in the computational domain.

Once the cell size is determined, the maximum size for the time step Δt immediately follows the Courant-Friedrichs-Levy (CFL) condition.

For 3D FDTD simulation, the CFL condition is:

1.16

$$\Delta t \leq \frac{1}{v \sqrt{\frac{1}{(\Delta x)^2} + \frac{1}{(\Delta y)^2} + \frac{1}{(\Delta z)^2}}}$$

where v is the speed of the light in medium.

For 2D simulations, the above CFL condition can be simplified as:

$$\Delta t \leq \frac{1}{v \sqrt{\frac{1}{(\Delta x)^2} + \frac{1}{(\Delta z)^2}}}$$



OptiFDTD Simulation Procedures

The following is the flow chart for the FDTD simulation in OptiFDTD. It also details the work flow in OptiFDTD.

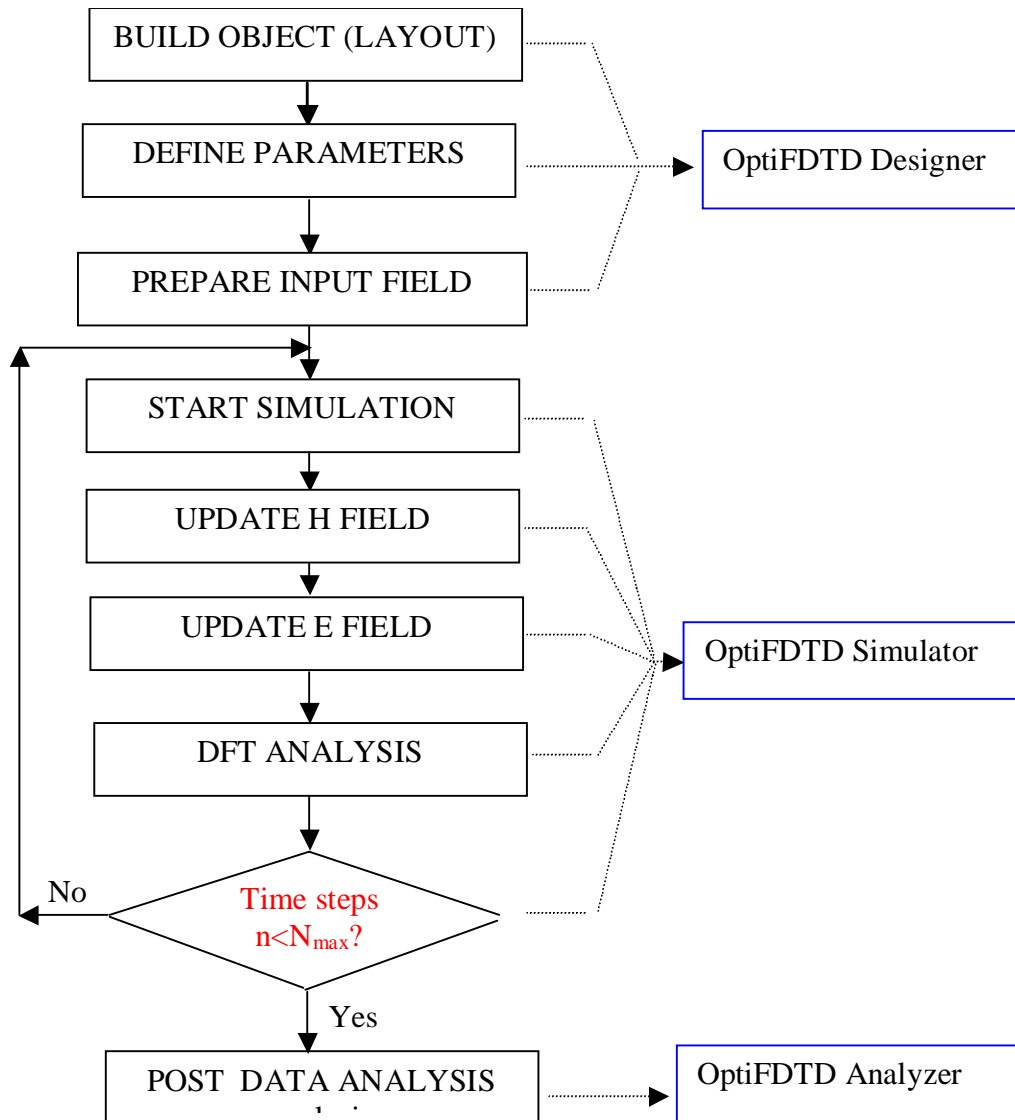


Figure 5 FDTD Simulation Flow Chart in OptiFDTD



Output data

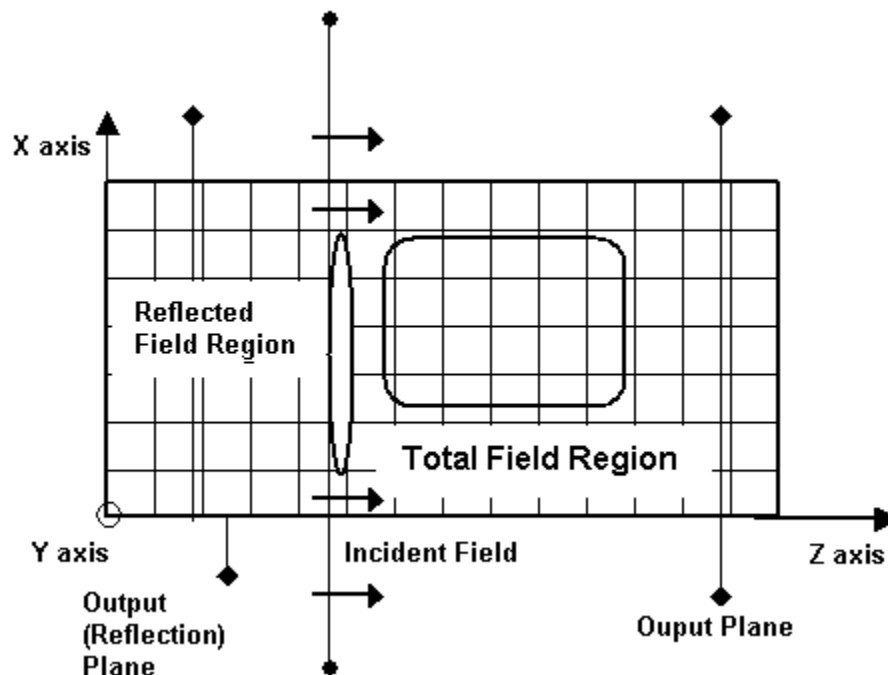
The fields propagated by the FDTD algorithm are the time domain fields. At each location of the computational domain they have a form similar to that given in Equation 8:

$$E_y(x,z) = BG(x,z)\sin(\omega t + \varphi_i) \quad (5)$$

where B is the amplitude of the field at that particular location, G is the wave profile, and φ_i is the corresponding phase. However, the values of B and φ_i are not accessible from the time domain field values.

In order to get the full amplitude/phase wave information, we need the stationary complex fields that correspond to the waveform Equation 5. The complex fields are the source of all useful information, such as output and reflected powers, overlap integrals with modal fields, etc. Those complex fields are calculated by a run time Fourier transform performed in the last time period of the simulation. The final complex fields can be visualized at specific Output Planes located properly in the computational domain.

Figure 6 Output Planes



FDTD BASICS

The Output Plane located on the right side of the Input Plane is in the Total Field Region and collects the Total Field data. The Output Plane on the left of the Input Plane is in the Reflected Field Region and collects Reflected Field data. It is also called the Reflection Plane. Output planes can also be situated along the Z axis.



Material Models

One of the main advantages of the FDTD approach is the lack of approximations for the propagating field—light is modeled in its full richness and complexity. The other significant advantage is the great variety of materials that can be consistently modeled within the FDTD context. In this sub-section we make a brief review of some of the main material properties that can be handled

Constant Dielectrics

Constant dielectric material is expressed by a complex refractive index value (\tilde{n}) or relative permittivity value (ϵ_r).

$$\begin{aligned}\tilde{n} &= n + \sqrt{-1} \cdot K = n + jK \\ \epsilon_r &= \epsilon_r' + j\epsilon_r'' \\ \epsilon_r &= \tilde{n}^2\end{aligned}$$

Here, n is the refractive index indicating the phase velocity information in the medium, while K is called the extinction coefficient, which indicates the amount of absorption loss when the electromagnetic wave propagates through the material. Note that the sign of the complex part is a matter of convention, which is important due to possible confusion between loss and gain. From OptiFDTD version 9, Engineering convention is used for the constant material definition, which means negative imaginary part will bring the loss effect.

Sellmeier equation can be used for calculating the permittivity with the reference wavelength (λ).

$$\epsilon_r = \epsilon_{r0} + \sum_{i=1}^M \frac{A_i \lambda^2}{\lambda^2 + j\Gamma_i \lambda - \lambda_i^2}$$

Where A_i is the strength, Γ_i is the damping factor or collision wavelength. λ_i is the oscillating wavelength



Lossy dielectrics

Before proceeding with a more detailed description it should be emphasized that the fact that in the time domain all the fields (H_x , E_y , H_z) are real quantities. Thus, accounting for loss is possible only through a non-zero conductivity σ of the medium:

$$\nabla \times \vec{H} = \epsilon_0 \epsilon_r \frac{\partial \vec{E}}{\partial t} + \sigma \vec{E} = i\omega \epsilon_0 \left(\epsilon_r - i \frac{\sigma}{\omega \epsilon_0} \right) \vec{E} = i\omega \epsilon_0 \epsilon_{eff} \vec{E} \quad (6)$$

where

$$\epsilon_{eff} = \epsilon_r - i \frac{\sigma}{\omega \epsilon_0} = \epsilon_e^{Re} + i \epsilon_r^{Im} = (n + i\kappa)^2$$

Here we have assumed that

$$\vec{E} \propto e^{i\omega t}$$

and

$$\frac{\partial}{\partial t} \rightarrow i\omega$$

corresponds to time-to-frequency domain Fourier transform. The real and imaginary part of the permittivity can be expressed through the real and imaginary part of the refractive index:

$$\epsilon_r^{Re} = n^2 - \kappa^2, \epsilon_r^{Im} = 2n\kappa, \kappa = -\sigma / 2\epsilon_0 \omega n \quad (7)$$

This makes the refractive index approach and the conductivity approach equivalent.



Lorentz dispersion materials

By Lorentz dispersion materials, we mean materials for which the frequency dependence of the dielectric permittivity can be described by a sum of multiple resonance Lorentzian functions:

$$\varepsilon_r(\omega) = \varepsilon_\infty + \sum_{m=1}^N \frac{\chi_0 G_m \omega_{0m}^2}{\omega_{0m}^2 + i\Gamma_m \omega - \omega^2}, \quad \sum_{m=1}^N G_m = 1 \quad (8)$$

where

ω_{0m}	are the resonant frequencies
G_m	is related to the oscillator strengths
Γ_m	is the damping coefficient
ε_∞	is the permittivity at infinite frequency
$\chi_0 = \varepsilon_s - \varepsilon_\infty$	is the permittivity at $\omega = 0$.
and ε_s	

In the lossless case [Equation 8](#) is directly related to the Sellmeier equation which in the three resonances can be presented as:

$$n^2 = \varepsilon_\infty + \frac{A_1 \lambda^2}{\lambda^2 - \lambda_1^2} + \frac{A_2 \lambda^2}{\lambda^2 - \lambda_2^2} + \frac{A_3 \lambda^2}{\lambda^2 - \lambda_3^2}, \quad A_m = \chi_0 G_m, \quad (m= 1, 2, 3) \quad (9)$$

In the lossy case, the Sellmeier equation can be written in a generalized form, accounting for a non-zero damping coefficient Γ_m as well as for anisotropy in the dispersion properties:

$$n^2(\omega) = \varepsilon_\infty + \frac{A_1 \lambda^2}{\lambda^2 + i\Gamma_{\lambda_1} \lambda - \lambda_1^2} + \frac{A_2 \lambda^2}{\lambda^2 + i\Gamma_{\lambda_2} \lambda - \lambda_2^2} + \frac{A_3 \lambda^2}{\lambda^2 + i\Gamma_{\lambda_3} \lambda - \lambda_3^2} \quad (10)$$



There are different ways to implement [Equation 8](#) into the FDTD formalism. Here we consider the so-called polarization equation approach in the single resonance case. It uses the dielectric susceptibility function:

$$\chi(\omega) = \frac{\chi_0 \omega_0^2}{\omega_0^2 + i\Gamma\omega - \omega^2} \quad (11)$$

and the relation between the polarization and the electric field $P_y = \epsilon_0 \chi(\omega) E_y$. Taking the Fourier transform of the last equation leads to the following differential equation:

$$\frac{\partial^2 P_y}{\partial t^2} + \Gamma \frac{\partial P_y}{\partial t} + \omega_0^2 P_y = \epsilon_0 \chi_0 \omega_0^2 E_y \quad (12)$$

By substituting $\frac{\partial P_y}{\partial t} = J_y$, the above equation becomes:

$$\frac{\partial J_y}{\partial t} + \Gamma J_y + \omega_0^2 P_y = \epsilon_0 \chi_0 \omega_0^2 E_y \quad (13)$$

Then [Equation 13](#) is solved numerically together with the modified [Equation 1](#):

$$\frac{\partial H_x}{\partial z} - \frac{\partial H_z}{\partial x} = \frac{\partial D_y}{\partial t} = \frac{\partial E_y}{\partial t} + \frac{\partial P_y}{\partial t} \quad (14)$$

The FDTD approach can also account for a large variety of materials such as Drude dispersion materials, perfect metal, second-order, and third-order materials.

Lorentz model only supports 2D simulation. Lorentz_Drude material that covers Lorentz model supports both 2D and 3D simulation.

Drude Model

Drude material in OptiFDTD is marked as



$$\epsilon_r = \epsilon_{r\infty} + \frac{\omega_p^2}{j\Gamma\omega - \omega^2}$$

Where $\epsilon_{r\infty}$ is the permittivity for infinity frequency, ω_p is the plasma frequency, and Γ is the collision frequency or damping factor.

Drude model only supports 2D simulation, Lorentz_drude model that covers Drude model supports both 2D and 3D simulation.

Nonlinear material model

In general, the nonlinear behavior is due to the dependence of the polarization $P(t)$ on the applied electric field, $E(t)$. Assuming an isotropic dispersive material, Maxwell's equations are:

$$\mu_0 \frac{\partial \vec{H}}{\partial t} = -\nabla \times \vec{E} \quad (15)$$

$$\frac{\partial \vec{D}}{\partial t} = \nabla \times \vec{H} \quad (16)$$

$$\vec{D} = \vec{P}^L + \vec{P}^{NL} + \sum_{m=1}^M \vec{P}_m^D \quad (17)$$



$$\frac{\partial^2 \vec{P}_m^L}{\partial t^2} + \Gamma_m \frac{\partial \vec{P}_m^L}{\partial t} + \omega_m^2 \vec{P}_m^L = \varepsilon_0 \chi_0 G_m \omega_m^2 \vec{E} \quad (18)$$

where P^L represents the linear polarization, in general $\vec{P}^L = \varepsilon_L \varepsilon_0 \vec{E}$, \vec{P}_m^D is the dispersive polarization which is controlled by Lorentz model in [Equation 18](#) and denotes the nonlinear polarization. For more information, see [“Dispersive third-order nonlinear material”](#) on page 21.



The nonlinear polarization \vec{P}_m^{NL} may come from various model sources that produce the different nonlinear phenomenon. Currently OptiFDTD can handle four kinds of nonlinearity:

- Dispersive second-order nonlinear material
- Dispersive third-order nonlinear material
- Dispersive Kerr effect
- Dispersive Raman effect

Dispersive second-order nonlinear material

In this model, the electrical displacement \vec{D} is

$$\vec{D} = \varepsilon_0 \varepsilon_L \vec{E} + \varepsilon_0 \chi^{(2)} : \vec{E} \vec{E} + \sum_{m=1}^M \vec{P}_m^D \quad (19)$$

where ε_L is the linear relative permittivity and $\chi^{(2)}$ is the second order isotropic susceptibility. They are the real values. In order to simulate second order nonlinear effect, you should input two parameters: the linear relative permittivity ε_L and the second order isotropic susceptibility $\chi^{(2)}$.

Dispersive third-order nonlinear material

Like the second-order nonlinearity, OptiFDTD takes third-order susceptibility to calculate the nonlinear polarization

$$\vec{D} = \varepsilon_0 \varepsilon_L \vec{E} + \varepsilon_0 \chi^{(3)} \text{N} \vec{E} \vec{E} \vec{E} + \sum_{m=1}^M \vec{P}_m^D \quad (20)$$

where ε_L is the linear relative permittivity and $\chi^{(3)}$ is the third order isotropic susceptibility.

Dispersive Kerr effect

If the time scale over which the medium changed is greater than the pulse width, we should take into account the effects of the finite response time of the medium. Followed by Prof. Richard W. Ziolkowski 's work [1]-[4], OptiFDTD treats the nonlinear effect with a finite response time as well as an instantaneous manner by



solving the phenomenological susceptibility equation simultaneously with Maxwell's equation:

$$\vec{D} = \epsilon_L \epsilon_0 + \vec{P}^{NL} + \sum_{m=1}^M \vec{P}_m^D \quad (21)$$

$$\vec{P}^{NL} = \epsilon_0 \chi^{NL}(\vec{r}, t, |E|^2) \vec{E} \quad (22)$$

$$\frac{\partial \chi^{NL}}{\partial t} + \frac{1}{\tau} \chi^{NL} = \frac{1}{\tau} \epsilon_2 |E|^2 \quad (23)$$

where

- ϵ_L is the linear relative permittivity
- χ^{NL} is the nonlinear susceptibility
- τ is the response time
- ϵ_2 is the Kerr model permittivity

Therefore, in order to simulate the Kerr effect, you should setup the three parameters, ϵ_L , τ , and ϵ_2 . Due to the numerical difficulties to update the susceptibility in the FDTD scheme, currently OptiFDTD for Kerr model is good for high-nonlinearity.

Dispersive Raman effect

Raman model allows another way to simulate the nonlinear phenomenon where the nonlinear susceptibility was modeled by a second-order derivative equation which is related to the resonant wavelength and the response time

$$\vec{D} = \epsilon_L \epsilon_0 + \vec{P}^{NL} + \sum_{m=1}^M \vec{P}_m^D \quad (24)$$



$$\vec{P}^{NL} = \epsilon_0 \chi^{NL} \vec{E} \quad (25)$$

$$\frac{\partial^2 \chi^{NL}}{\partial t^2} + \omega_R^2 \tau_R \frac{\partial \chi^{NL}}{\partial t} + \omega_R^2 \chi^{NL} = \epsilon_R \omega_R^2 |E|^2 \quad (26)$$

where

ϵ_L is the linear relative permittivity

χ^{NL} is the nonlinear susceptibility

τ is the response time

ϵ_R is Raman model permittivity

ω_R is the Raman model resonant frequency

In order to simulate the Raman effect, set four parameters for Raman model: ϵ_L , ϵ_R , τ , and ω_R .

Nonlinearity simulation

- To observe nonlinear effects in common used materials, a high-intensity light source is required. You should pay special attention to the input wave amplitude and/or the power level; each model with different parameters may need different input power or amplitude. If the input power is too low, you may not observe the nonlinear phenomenon. If the power is too strong, the nonlinear effect may be over saturable.
- The OptiFDTD takes Lorentz dispersive effect to the nonlinear effect. But it can work independently.



Lorentz-Drude Model

Lorentz-Drude Model in Frequency Domain

It has been shown [1] that a complex dielectric function for some metals and surface plasmas can be expressed in the following form:

$$\varepsilon_r(\omega) = \varepsilon_r^f(\omega) + \varepsilon_r^b(\omega) \quad (1)$$

This form separates explicitly the intraband effects (usually referred to as free electron effects) from interband effect (usually referred to as bound-electron effects). The intraband part $\varepsilon_r^f(\omega)$ of the dielectric function is described by the well know free-electron or Drude model [2][3]:

$$\varepsilon_r^f(\omega) = 1 + \frac{\Omega_p^2}{j\omega\Gamma_0 - \omega^2}; \quad (2)$$

The interband part of the dielectric function is described by the simple semiquantum model resembling the Lorentz results for insulators:

$$\varepsilon_r^b(\omega) = \left(\sum_{m=1}^M \frac{\Omega_p^2}{\omega_m^2 - \omega^2 + j\omega\Gamma_m} \right) \quad (3)$$

where ω_p is the plasma frequency, m is the number of oscillators with frequency ω_m and lifetime $1/\Gamma_m$, where $\Omega_p = \sqrt{G_m}\omega_p$ is the plasma frequency as associated with intraband transitions with oscillator strength G_0 and damping constant Γ_0 .

The above Lorentz-Drude Model can be expressed as the more general equation:

$$\varepsilon_r(\omega) = \varepsilon_{r,\infty} + \sum_{m=0}^M \frac{G_m\Omega_m^2}{\omega_m^2 - \omega^2 + j\omega\Gamma_m} \quad (4)$$

where $\varepsilon_{r,\infty}$ is the relative permittivity in the infinity frequency. Ω_m is the plasma frequency, ω_m is the resonant frequency, and Γ_m is the damping factor or collision frequency.

In this general equation, if only the term $m = 0$ exists, and $\omega_0 = 0$, then the general equation describes the Drude model as in (2). If only the $m = 1 \dots M$ term



exists, and $\Omega_1 = \Omega_2 = \dots = \Omega_M$; then the general model becomes the Lorentz model as in (3). This model can also work as the separate Drude and Lorentz models.

Reference [1] also gives the LD parameters for 11 noble metals; their unit is in electron volts. [Lorentz_Drude parameters for selected materials](#) contains parameters compiled by Optiwave that describe noble metals.

Lorentz-Drude Model in Time Domain

The Lorentz-Drude model in (4) is in the frequency domain. However, FDTD is a time domain method and therefore would be suitable for broadband simulations. We need to transform (4) to time domain so that FDTD can handle the fullwave-analysis for the Lorentz-Drude material. This transformation to time domain is accomplished by using the Polarization philosophy within Maxwell's equation. The Lorentz-Drude model in time domain can be expressed:

$$\mu_0 \frac{\partial \vec{H}}{\partial t} = \nabla \times \vec{E} \quad (5)$$

$$\epsilon_{r, \infty} \epsilon_0 \frac{\partial \vec{E}}{\partial t} + \sum_{m=0}^M \frac{\partial \vec{P}_m}{\partial t} = -\nabla \times \vec{H} \quad (6)$$

$$\frac{\partial^2 \vec{P}_m}{\partial t^2} + \Gamma_m \frac{\partial \vec{P}_m}{\partial t} + \omega_m^2 \vec{P}_m = \epsilon_0 G_m \Omega_m^2 \vec{E} \quad (7)$$

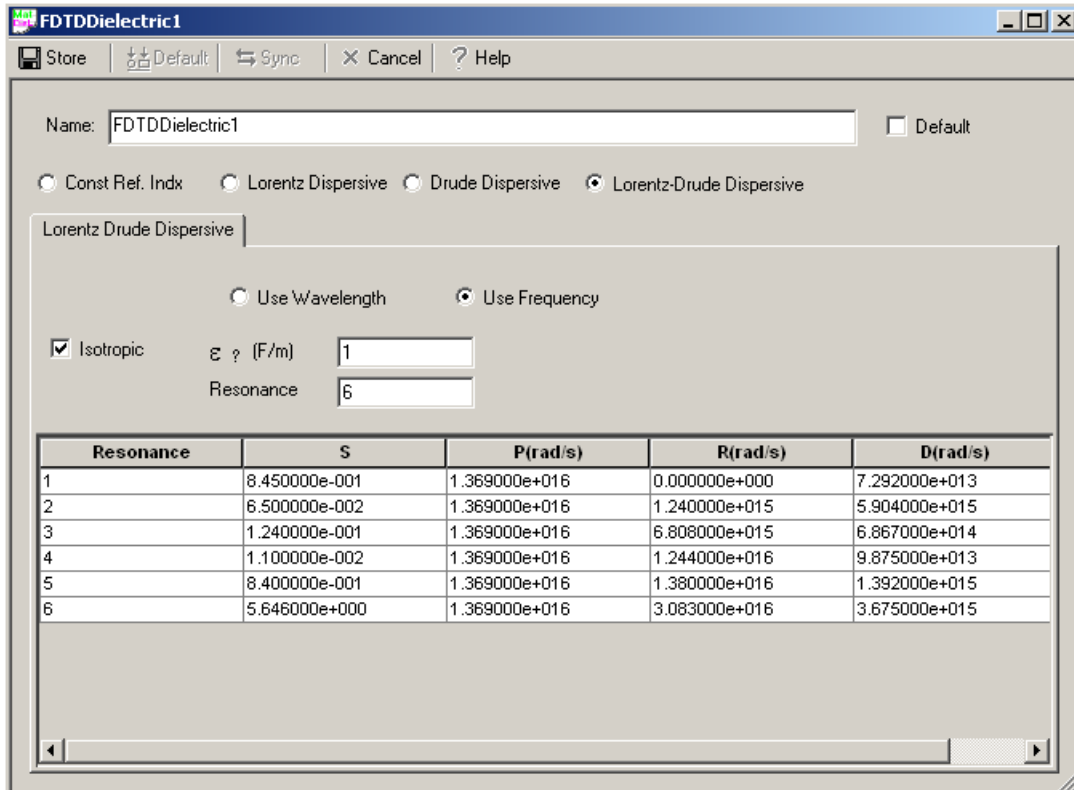
The FDTD algorithm can be derived based on the above equation.



Lorentz-Drude model user interface in OptiFDTD

The Lorentz-Drude model user interface is shown in [Figure 22](#).

Figure 7 Lorentz-Drude material definition data entry interface



where:

- **S** = Strength of the corresponding resonance terms
- **P (rad/s)** = Plasma frequency
- **R (rad/s)** = Resonant frequency
- **D (rad/s)** = Collision frequency (or damping factor)

Note: Refer to the Technical Background description when you first start preparing metal simulations. The parameters of aluminum are located in [Lorentz_Drude parameters for selected materials](#).



References:

- [1] Aleksandar D. Rakic, Aleksandra B. Djuricic, et. al., "Optical Properties of Metallic Films for Vertical - Cavity Optoelectronic Devices". 1998 Optical Society of America, August, Vol. 37, No. 22, Applied Optics, pp. 5271-5283.
- [2] M. I. Markovic and A. D. Rakic, " Determination of reflection coefficients of laser light of wavelength $\lambda \in (0.22\mu m, 200\mu m)$ from the surface of aluminum using the Lorentz-Drude model", Appl. Opt. 29, 3479-3483 (1990).
- [3] M. I. Markovic and A. D. Rakic, " Determination of optical properties of aluminum including electron reradiation in the Lorentz-Drude Model", Opt. Laser technol. 22, 394-398, (1990).





OptiFDTD Boundary Conditions

PML Boundary Conditions

The basic FDTD algorithm must be modified at the boundaries of the computational window where suitable numerical absorbing boundary conditions (ABC) are applied. This is one of the most challenging parts of FDTD simulations. There are several choices for the type of boundary conditions. The Perfectly Matched Layer (PML) boundary conditions have the best performance. Our FDTD simulator uses the Anisotropic PML, or so-called Un-split PML (UPML) version. The theory of the UPML is very well explained in some of the references given here. The UPML boundary conditions are physical rather than numerical because their implementation is based on a Maxwellian formulation rather than on a mathematical model. Their absorbing properties are physically equivalent to the properties of an absorbing uni-axial anisotropic medium with the following permittivity and permeability tensors:

$$\hat{\epsilon} = \epsilon \hat{S}, \hat{\mu} = \mu_0 \hat{S}, \hat{S} = \begin{pmatrix} s^{-1} & 0 & 0 \\ 0 & s & 0 \\ 0 & 0 & s \end{pmatrix}, s = \kappa - i \frac{\sigma}{\epsilon_0 \omega} \quad (4)$$

A plane wave incident on a half space composed of the above uni-axial medium with an interface in the $x = \text{const}$ plane is purely transmitted into it. The reflectionless property is completely independent of the angle of incidence, polarization and frequency of the incident wave. The numerical implementation of the UPML in a 2D (X-Z) computational window requires the introduction of such perfectly matched absorbing layers on all the sides. The corner regions need special attention. In these regions the tensor \hat{S} from [Equation 4](#) must be modified to:

$$\hat{S} = \begin{pmatrix} s_x^{-1} & 0 & 0 \\ 0 & s_x & 0 \\ 0 & 0 & s_x \end{pmatrix} \begin{pmatrix} s_z & 0 & 0 \\ 0 & s_z & 0 \\ 0 & 0 & s_z^{-1} \end{pmatrix}, s_x = \kappa_x - i \frac{\sigma_x}{\epsilon_0 \omega}, s_z = \kappa_z - i \frac{\sigma_z}{\epsilon_0 \omega} \quad (5)$$



The minimization of the numerical reflectance of the Anisotropic PML layers requires spatial scaling of the conductivity profile from zero (at the interface of the PML) to a maximum value at the end of the computational window:

$$\sigma(x) = \sigma_{max} \left(\frac{x}{L}\right)^m, \quad \kappa(x) = 1 + (\kappa_{max} - 1) \left(\frac{x}{L}\right)^m \quad (6)$$

where L is the thickness of the Anisotropic PML. Typical values for the parameter m are between 2 and 4.

PMC/PEC boundary conditions and plane wave simulation

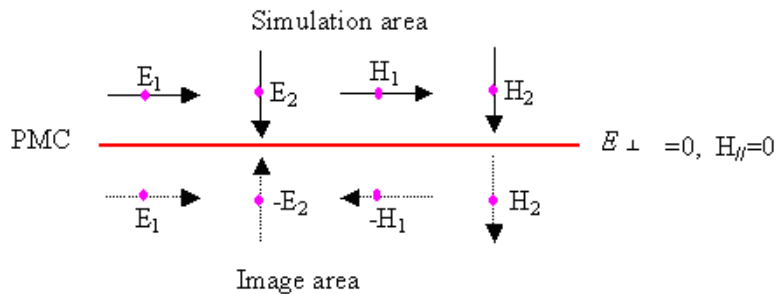
OptiFDTD now has options to use Perfect Electrical Conductor (PEC) and Perfect Magnetic Conductor (PMC) boundary conditions. You can choose which boundaries use the new conditions, and Anisotropic PML can be used for the remaining boundaries. With this PEC/PMC/Anisotropic PML combination, the following simulations may be obtained:

- Plane wave simulation
- Domain reduced simulation for symmetric, periodic, or photonic band gap structures

Image value of PEC/ PMC

The following graphs show the field set up in the PEC/PMC wall (zero thickness) and its image value

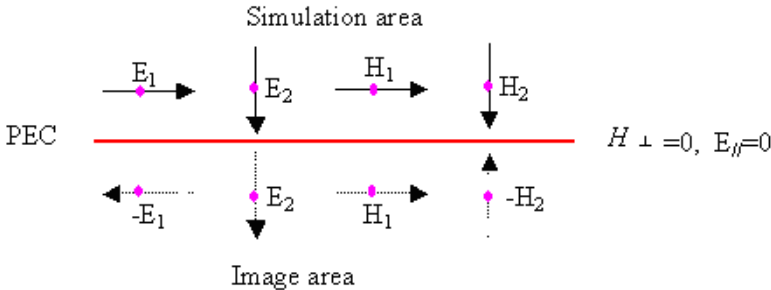
Figure 8 Field in PMC and image area



(E_{\perp} is the vertical electric component in the PMC wall, and H_{\parallel} is the parallel magnetic component in the PMC wall.)



Figure 9 Field in PEC and image area



As we can see from Figure 8, PMC is a symmetric wall for the symmetric structure with symmetric wave propagation. The following two cases details the results when PMC occurs.

Figure 10 PMC wall in a symmetric waveguide—excited by symmetric TE waveguide mode

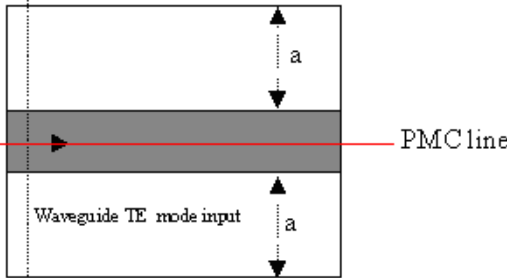
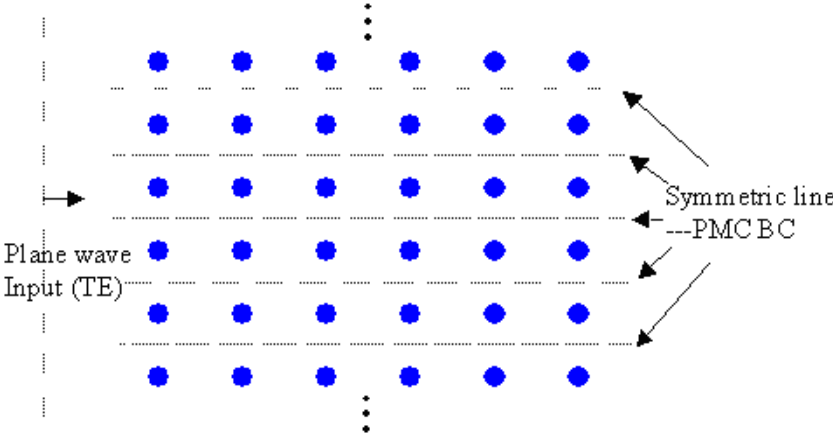


Figure 11 PMC wall in a periodic structure for TE plane wave propagation



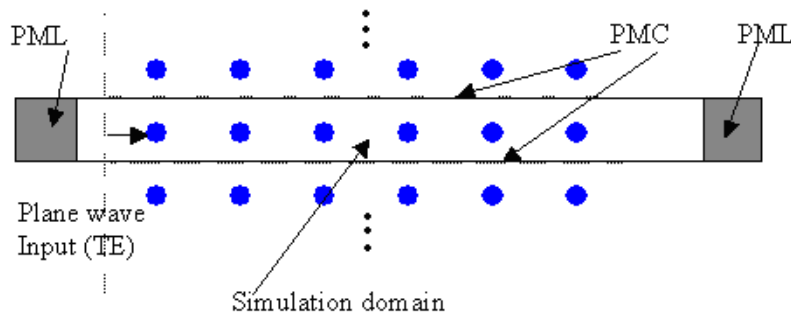
PMC can be seen as the special case for Bloch's boundary condition (periodic boundary condition) where the k -vector is set to zero in the corresponding direction.

PEC line is the complement of PMC, so in [Figure 10](#), and [Figure 11](#), the PMC line will become the PEC line if the wave polarization is changed to TM.

Plane wave realized in symmetric/periodic structure

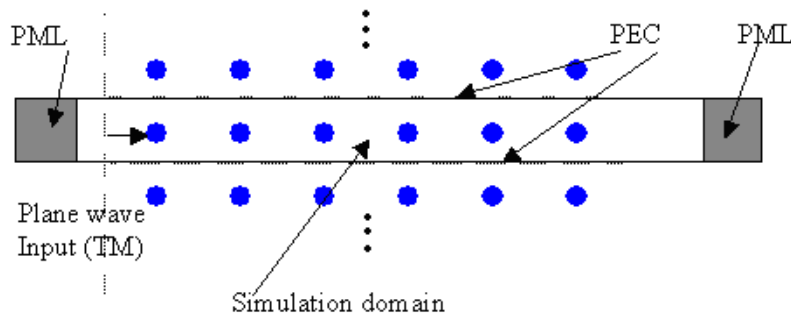
[Figure 12](#) shows how the plane wave simulation can be realized for a symmetric structure. For a 2D TE simulation, the edge of transverse plane should be set to the PMC boundary condition to realize the plane wave.

Figure 12 Plane wave in TE simulation



For a 2D TM simulation, the edge of transverse plane should set to the PEC boundary condition to realize the plane wave (see [Figure 13](#)).

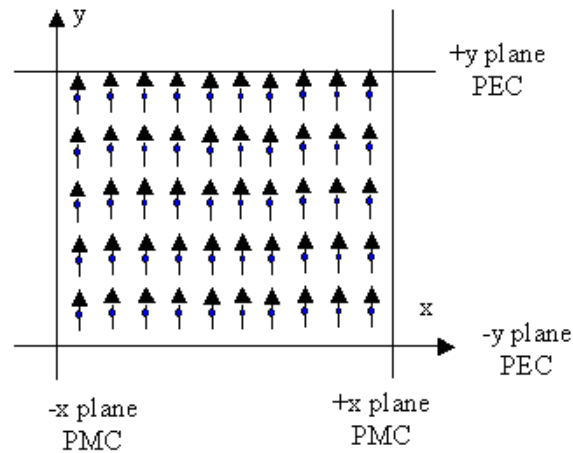
Figure 13 Plane wave in TM simulation



For a 3D simulation, the plane wave realization depends on the wave polarization and the boundary condition setup at different edges of the transverse plane. If the wave goes in z -direction, and the input wave is in y -direction polarization, then the y plane (x - z) edge should be set to the PEC and x -plane (y - z plane) edge set to the PMC boundary (see [Figure 14](#)).

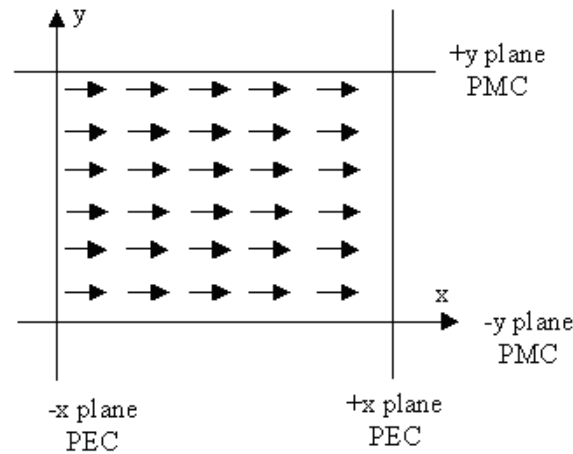


Figure 14 Y-polarization plane wave (z-direction propagation) with boundary conditions



For 3D simulation, if the wave goes in z-direction, and the input wave is in x-direction polarization, then the y plane (x-z) edge should be set to the PMC and x-plane (y-z plane) edge set to the PEC boundary (see [Figure 15](#)).

Figure 15 X-polarization plane wave (z-direction propagation) with boundary conditions



The plane wave shape can be set by setting the rectangular wave parameters in the **Input Wave Properties** dialog box. Currently, plane wave does not support the tilting angle. Currently, the plane wave simulation is only effective for symmetrical structures.



PBC Boundary Conditions

This version of OptiFDTD provides the option to use simplified Periodic Boundary Condition (PBC). PBC can work with other boundary conditions such as Anisotropic PML, PMC, and PEC. With PBC, you can generate a simple plane wave simulation or periodic layout simulations.

The simplified PBC is based on the Bloch's Theorem:

- For the periodic layout, the wave function is written as the combination of a cell periodic component and a wave-like component:

$$\psi(\gamma + \Delta\gamma) = \varphi(\gamma) \cdot \exp(jk\Delta\gamma)$$

- The equation above needs to have a pre-defined value for the k -vector; which is not so feasible for an FDTD simulation, especially for Pulse input.

Therefore, we simplified the application by setting the k -vector in one specific direction as zero, which then leads to the input wave being the axis-propagated wave, and then the equation becomes:

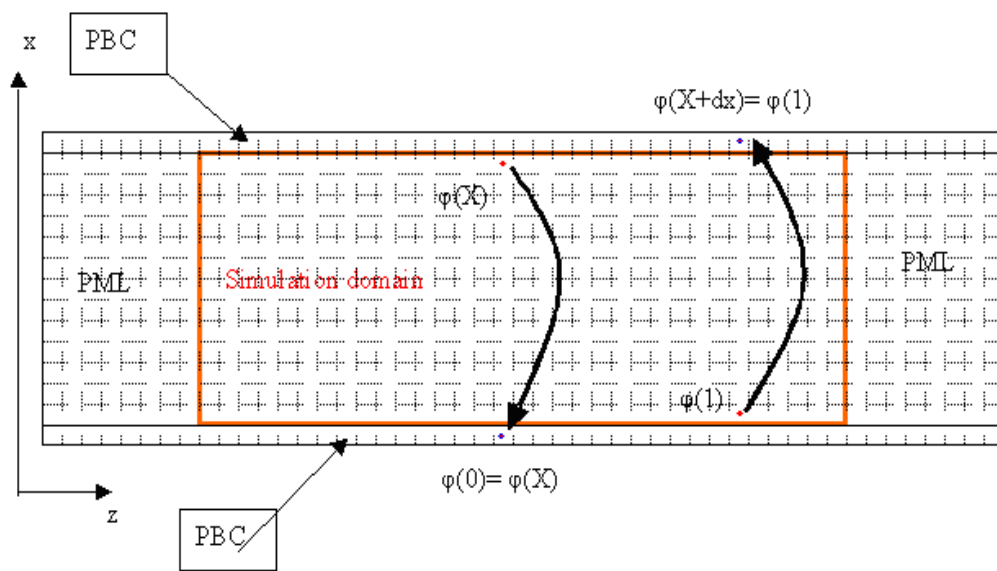
$$\psi(\gamma + \Delta\gamma) = \varphi(\gamma)$$

In an OptiFDTD application, $\Delta\gamma$ in the simplified is the periodic length or one dimensional length the edge of which is set to periodic boundary condition.

$\varphi(\gamma)$ is the field component at the edge of the simulation domain.

$\psi(\gamma + \Delta\gamma)$ is the corresponding field value at the boundary of the opposite edge of the $\varphi(\gamma)$.

The following graph shows the relationship.



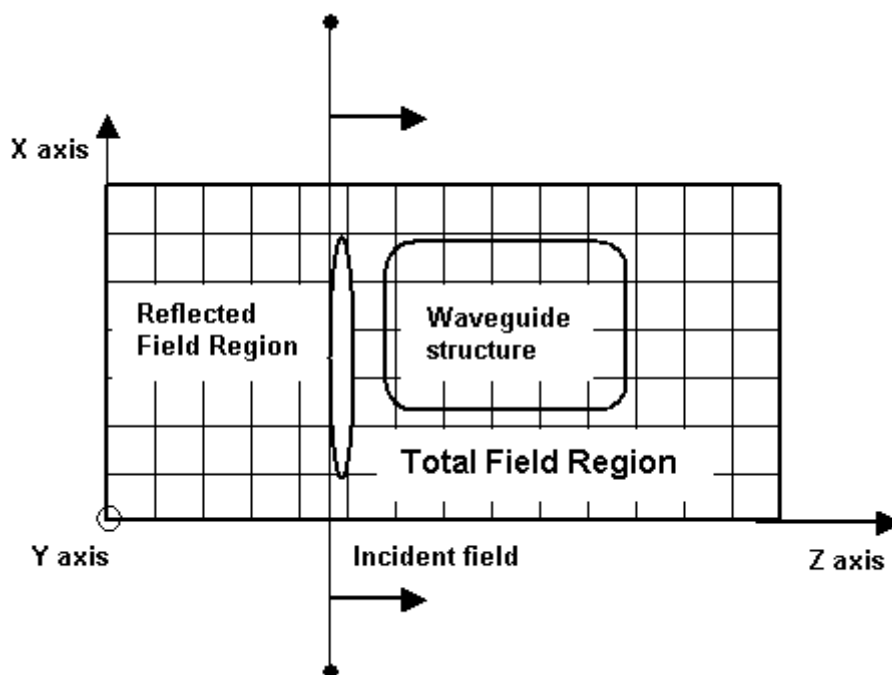
Input Wave

Incident wave source excitation — Total/Reflected field formulation

The FDTD numerical scheme yields the solution of an initial value problem. At the first time step of the simulation all the fields are set to zero. The algorithm needs the initial field excitation that will be propagated through the computational domain. The FDTD Total/Reflected Field formulation gives the methodology in defining a +Z propagating incident field. The computational domain is separated into two sub-regions — the **total field region** and the **reflected field region**. The plane separating these regions is called the **incident field** (Figure 16).

In the Total Field Region, the waveguide structures of interest are designed. The interaction between the incident field and the waveguide structure will take place in this region. That is why the Total Field Region contains information for both the incident and scattered (reflected) waves. In the Reflected Field Region the geometry is uniform and the propagating waves are presented by the fields reflected from the Total Field Region. There are no objects in this region and the signal will not be reflected back to the total field region.

Figure 16 Total/Reflected field formulation



CW or pulsed excitations can be used. One can consider the incident field as being generated by a flashlight located on the incidence plane facing the +Z direction. Before starting the simulation the flashlight is turned off and the field values in the



whole computational domain are equal to zero. The flashlight is switched on at $t = 0$ and illuminates only the Total Field Region. If the excitation scheme is perfect, there should not be any light detected by an observer located in the Reflected Field Region, unless there are some obstacles which would generate the reflections. The incident wave can be generated by specifying the exact field distribution on the incident plane at each time interval.

CW excitation

In CW excitation, the time dependence of the incident field is a single frequency sinusoidal function. For example the incident E_y field has the following form:

$$E_y^{inc}(x, z_{inc}) = AF(x, z_{inc}) \sin(\omega t + \theta_i) \quad (7)$$

where A is the field amplitude, $AF(x, z_{inc})$ is the transverse field distribution at the incident plane location z_{inc} .

The initial phase offset θ_i is the phase difference between points in the incidence plane. This offset can be adjusted to define the direction of the incident field. $\omega = (2\pi/\lambda)c$ is the frequency of the input wave. In the CW case the optical wave analog propagates until it reaches the stationary state everywhere in the computational window.

Pulsed excitation

For pulsed excitations the incident field has the form:

$$E_y^{inc}(x, z_{inc}) = AT(t)F(x, z_{inc}) \sin(\omega t + \theta_i) \quad (8)$$

where

$$T(t) = \exp\left[-\frac{1}{2}\left(\frac{t-t_{off}}{t_0}\right)^2\right] \quad (9)$$

is the pulse envelope function, t_{off} is the time offset and t_0 is the pulse width parameter.

For pulsed excitations the time stepping continues until the desired late-time pulse response is observed at the field points of interest.

Point Source

This version of OptiFDTD includes a new type of excitation - Point Source. Point source can also be referred to as a radiation source. For this new source, the input



wave is only functional with one field component at one single point. You can specify which field component is required to add this source.

In the case of CW, the point source is expressed as:

$$F_{i,j,k} = F_{i,j,k} + A \cdot [-\exp(-t/T)] \cdot \sin(\omega t)$$

where (i,j,k) is the user-specified position and F is the user specified component, A is the point source amplitude, T is the time delay and w is the angle frequency. $F_{i,j,k}$ represents the FDTD simulation results, and the last term in the equation is the enforced point source excitation.

For the GMCW, point source is expressed as

$$F_{i,j,k} = F_{i,j,k} + A \cdot \exp(-0.5 \cdot (t - t_0)^2 / T^2) \cdot \sin(\omega t)$$

where t_0 is time offset and T is the half width.

Note:

- Point sources can work with other kinds of source (such as input plane source).
- Point sources can be either continuous wave (CW) or Gaussian modulated continuous wave (GMCW).
- Point sources works for both 2D and 3D simulations.
- Multiple point sources can be utilized in OptiFDTD.
- When Point source is used as the key input. The normalized power calculation will be disabled in analyzer

Gaussian Beam Size

In OptiFDTD, transverse Gaussian Beam is expressed as

$$E(x) = A \cdot \exp\left[-\frac{(x - x_0)^2}{2T^2}\right]$$

where x_0 is the center position and T is being called as half width.

In general, Gaussian Beam radius is the radius at which the field amplitude and intensity drop to $1/e$ and $1/e^2$, respectively. Gaussian Beam Size or Gaussian Beam Spot size is the beam diameter which is two times of Beam Radius. Suppose the beam size is denoted as a , which means



$$E\left(x = \frac{a}{2}\right) \Big|_{x_0 = 0} = \exp(-1) = \exp\left(-\frac{a^2}{8T}\right)$$

This means

$$T = \frac{a}{2\sqrt{2}}$$

Please use the above formula to set the half width in OptiFDTD for your desired Gaussian Beam size.

2D Total Field /Scattering Field (TF/SF) region.

The Total-field/Scattered-field (TF/SF) technique results from attempts to realize any tilting plan-wave source that avoids the difficulties caused by using either the hard source or the boundary conditions. 2D TF/SF is a special type of formula that generates a wave in the enclosed rectangular surface. Inside the rectangular region, it generates the total field (including incident wave and scattering wave together). Outside of this rectangular region, it generates the pure scattering field or reflected field. [Figure 17](#) shows a 2D sketch for 2D TF/SF. TF/SF used special numerical formula to separate the total field and scattering field. A 2D free space TF/SF response is shown in [Figure 18](#)



Figure 17 TF/SF Sketch

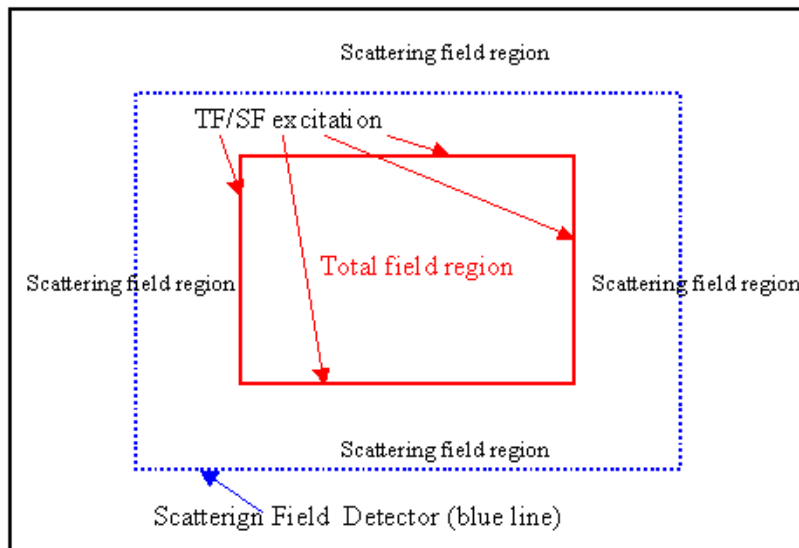
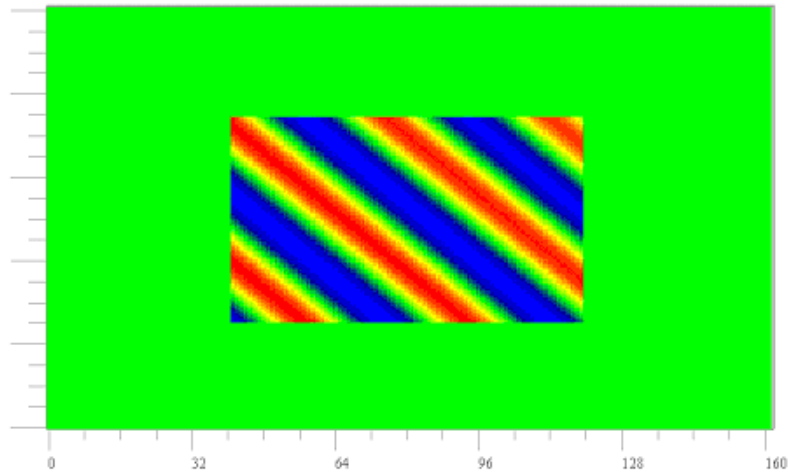


Figure 18 Field response for a TF/SF sketch



In OptiFDTD, it is the user's choice to set up the total field working area position, size and the scattering field detector position. After the simulation, the steady state scattering field response can be obtained in the scattering field detector. If all four scattering- field detector lines are active, Radar Cross Section (RCS) can also be performed based on the near scattering field response, RCS calculation formula is listed in the post-simulation data analysis section.



2D FDTD Band Solver

The band solver in OptiFDTD is an integrated CAD tool and simulation engine for analyzing the photonic crystal and photonic band gap structure. Currently it employs the FDTD method and generates band-diagrams.

Simulation concept introduction

As we know, the periodic structure or the lattice structure has the mode selection function. The task of the band solver is to find these mode positions based on one or several basic lattice cell. The key points for FDTD simulation come from:

- How can the FDTD method extract the mode?
- How can the FDTD method handle several basic cells and generate global results?

The first question can be addressed in two parts:

- set the reasonable initial fields that can excite out all necessary modes
- get the eigenvalues (frequencies) from the Fourier spectrum of the field time sequence somewhere in the periodic cell. The second question can be solved by using the Bloch's boundary condition with defined k-vector.

In summary, when a field pattern is excited in the first time step, the steady state oscillating mode which will satisfy the Bloch's boundary condition will be found through FDTD simulation in the defined periodic cell.

Note:

- To extract all the excited eigenvalues, observation points to record the time domain series are needed.
- Some of the mode may not be excited.
- Because of the above points, the FDTD band solver cannot be guaranteed to find all the eigenvalues.



Basic equation for TE mode 2D simulation

$$\begin{aligned}
\mu_0 \frac{\partial H_x}{\partial t} &= \frac{\partial E_y}{\partial z} & \text{a} \\
\mu_0 \frac{\partial H_z}{\partial t} &= -\frac{\partial E_y}{\partial x} & \text{b} \\
\varepsilon \frac{\partial E_y}{\partial t} + \sigma E_y &= \frac{\partial H_x}{\partial z} - \frac{\partial H_z}{\partial x} & \text{c}
\end{aligned} \tag{10}$$

Basic equation for TM mode 2D simulation

$$\begin{aligned}
\mu_0 \frac{\partial H_y}{\partial t} &= \frac{\partial E_z}{\partial x} - \frac{\partial E_x}{\partial z} & \text{a} \\
\varepsilon \frac{\partial E_x}{\partial t} + \sigma E_x &= -\frac{\partial H_y}{\partial z} & \text{b} \\
\mu_0 \frac{\partial E_z}{\partial t} + \sigma E_z &= \frac{\partial H_y}{\partial x} & \text{c}
\end{aligned} \tag{11}$$

Note:

- The above equations are same as the equations used in conventional FDTD simulations. However, because the Bloch's boundary condition is used in the simulation, all the field components in band solving are complex values.
- The discretization treatment for the FDTD method and simulation domain is same as conventional FDTD simulation.

Bloch's boundary condition

Bloch's theorem tells us that for periodic structure, field components have the following properties:

$$\vec{\Psi}(\vec{r} + \vec{R}, t) = \Psi(\vec{r}, t) e^{j\vec{k} \cdot \vec{r}} \tag{12}$$

where \vec{R} is the lattice vector, \vec{k} is the wave vector. Equation 12 is the boundary condition used in the OptiFDTD band solver.



Initial excitation

Unlike conventional FDTD simulations where time domain excitation is continuous wave and lasts on only some time steps, the FDTD band solver sets the initial value in the first time step, and this initial field is expected to have non-zero projection on the normal modes we are interested in.

Example: At $t = 0$:

$$\vec{E}(\vec{r}) = 0 \quad (13)$$

$$\vec{H}(\vec{r}) = \sum_G \vec{h}_0(\vec{k} + \vec{G}) e^{k(\vec{k} + \vec{G})\vec{r}} \quad (14)$$

$$\vec{h}_0(\vec{k} + \vec{G}) = \vec{v} \times (\vec{k} + \vec{G}) \quad (15)$$

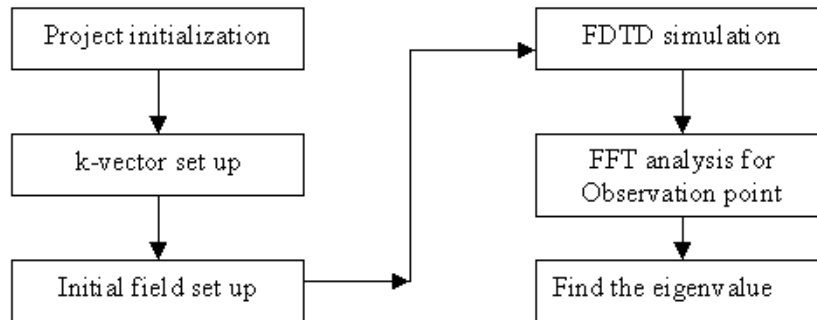
\vec{v} is chosen as the unit vector along the Cartesian system coordinator.

This keeps $\nabla \cdot \mu \vec{H} = 0$.



Figure 19 Flow chart of FDTD band solver

Flow chart of FDTD band solver

**Note:**

- In OptiFDTD, the FDTD band solver only deals with the 2D square lattice and 2D hexagonal lattice.
- In OptiFDTD, the band solver only accept lossless Isotropic and Anisotropic materials.

Unit cell and Brillouin zone

The following figures show the unit cell and Brillouin zone in the OptiFDTD 2D FDTD band solver.



Figure 20 Unit cell and associated Brillouin zone for square lattice

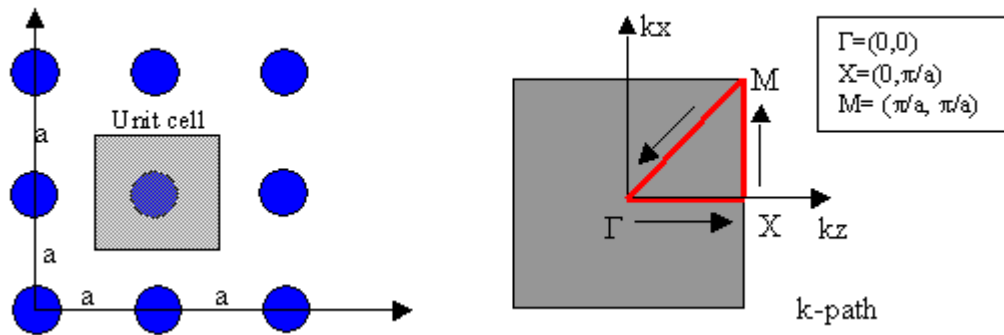
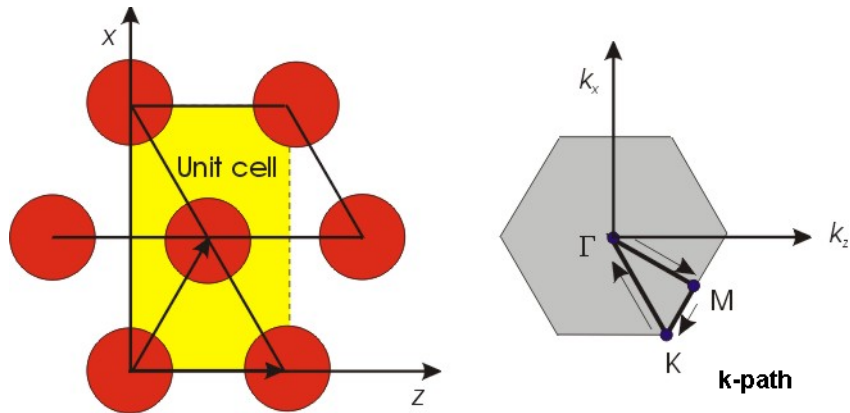


Figure 21 Unit cell and Brillouin zone for Hexagonal lattice



References:

- [1] J. B. Pendry, "Calculating photonic band structure", *J. Phys.*, **No. 8**, 1085-1108, 1996.
- [2] A. J. Ward, J.B. Pendry, " Calculating photonic Green's functions using a non-orthogonal finite difference time-domain method", **PACS**.



Post-simulation Data Analysis

OptiFDTD provides comprehensive post-simulation data analysis tools in the Simulator and Analyzer.

Discretized Fourier Transform (DFT) and Fast Fourier Transform (FFT)

As a time domain simulation method; FDTD can get all the relevant spectral response with a single simulation. To get the spectral response, you need to use the DFT, FFT, and Analysis. Discretized Fourier Transform gets a single wavelength response from a time series.

1.33

$$S(\omega) = \int_0^T s(t)e^{-j\omega t} dt = \sum_{n=0}^N s(n)e^{-j\omega n\Delta t} \Delta t$$

where $s(n)$ are the time domain response, N is the number of time steps, and ω is the angle frequency.

When DFT is running in the simulator, it will get the frequency domain response only for the center wavelength, while DFT for the observation point, area, and line gives the spectral response for a series of wavelengths which are identified by the user.

Fast Fourier Transform uses the traditional fast Fourier transform scheme to get a spectral response from the zero frequency to the cutoff frequency $1/(2Dt)$; and the frequency domain sampling step is $1/(2NDt)$.

In general, the sampling frequency step for FFT is comparable to the wavelength due to the fact that the FDTD required time step is very small. Therefore, the FFT results may have a larger error than that of the DFT results, but the FFT method is much faster than DFT.

Power calculation and Poynting vector

For the z-direction propagation wave. The total power in x-y plan can be divided into two power values: x-direction polarized z-direction propagation power (P_{z-x}) and y-direction polarized z-direction propagation power (P_{z-y}). The corresponding formulas are:

$$\text{x-polarization power} \quad P_{z-x} = \text{Re}\left(\frac{1}{2} \iint_s \mathbf{E}_x \times \mathbf{H}_y^* dx dy\right) \quad 1.34a$$



$$\text{y-polarisation power } P_{z-y} = -\text{Re}\left(\frac{1}{2} \iint_s \hat{E}_y H_x^* dx dy\right) \quad 1.34b$$

$$\text{Total power } P_z = P_{z-x} + P_{z-y} = \text{Re}\left(\frac{1}{2} \iint_s \hat{E}_x H_y^* dx dy\right) - \text{Re}\left(\frac{1}{2} \iint_s \hat{E}_y H_x^* dx dy\right) \quad 1.34c$$

where the cap dot indicates the complex value that comes from the DFT calculation, and the superscript star indicates the complex conjugate value.

The z-direction Poynting for a point (i,j) in x-y plane is:

$$S_{z,i,j} = \frac{1}{2} \hat{E}_{x,i,j} H_{y,i,j}^* - \frac{1}{2} \hat{E}_{y,i,j} H_{x,i,j}^* \quad 1.35$$

The Poynting vector is a complex value. In OptiFDTD, only the amplitudes are displayed to the user.

Overlap Integral (OI)

Overlap Integral do the inner product and integral calculation for the two electric fields in a specified region. The results can also be seen as the Correlation Function, or as a comparison between the two fields. The Overlap Integral (MOI) is defined as:

$$OI = \frac{\left| \iint_s \hat{E}_1(x, y) \cdot \hat{E}_2^*(x, y) dx dy \right|^2}{\iint_s \left| \hat{E}_1(x, y) \right|^2 dx dy \iint_s \left| \hat{E}_2(x, y) \right|^2 dx dy} \quad 1.36$$

The cap dot represents the complex value, and the superscript star represents the conjugate value, \hat{E}_1 is the first field component, and \hat{E}_2 is the second field component.

Mode Overlap Integral (MOI)

For mode overlap integral calculation, the first component in eq.1.36 are the OptiFDTD simulated DFT results in a selected x-y plane, and the second components are the modal components that come from the mode solver for the same x-y plane.

Input Overlap Integral (IOI)

For Input Overlap Integral, the first component \hat{E}_1 in Equation 1.36 are the OptiFDTD simulated DFT results in a selected x-y plane, and the second component \hat{E}_2 is the input wave in the input plane. The input overlap integral is also called the power overlap integral. The input overlap integral provides the criteria to do the comparison between the output in the selected plane and the input wave.



Input Overlap Integral Scan (IOIS)

The Input Overlap Integral Scan makes the Input Overlap Integral calculations for all the x-y slices in the z-direction. This means that it scans the IOI calculation in the z-direction, and the results are provided to the user interface. Users can observe percentages of output power in each slice. Far Field Transform.

Far Field Transform

Fraunhofer approximation

Narrow angle far-field transform being used in OptiFDTD is based on the Fraunhofer approximation [1]:

(1)

$$E(x, y, z = d) \cong \frac{ie^{ikd} e^{i\frac{k}{2d}(x^2+y^2)}}{\lambda d} \iint E(x', y', 0) e^{-i\frac{k}{d}(xx' + yy')} dx' dy'$$

At a large distance d, the far field position can be expressed by the far field angle,

(2)

$$\tan(\theta_x) = \frac{x}{d}; \tan(\theta_y) = \frac{y}{d}$$

Where the x-directional angle (θ_x) is the angle between the original yz-plane and the shortest straight line connecting the point and the Y axis, and y-directional angle (θ_y) is the angle between the original xz-plane and the shortest straight line connecting the point and the x axis. The far field angle is also shown in the [Figure 20](#).

Associated with the angle where to observe the far-field, far-field formula now can be simplified as

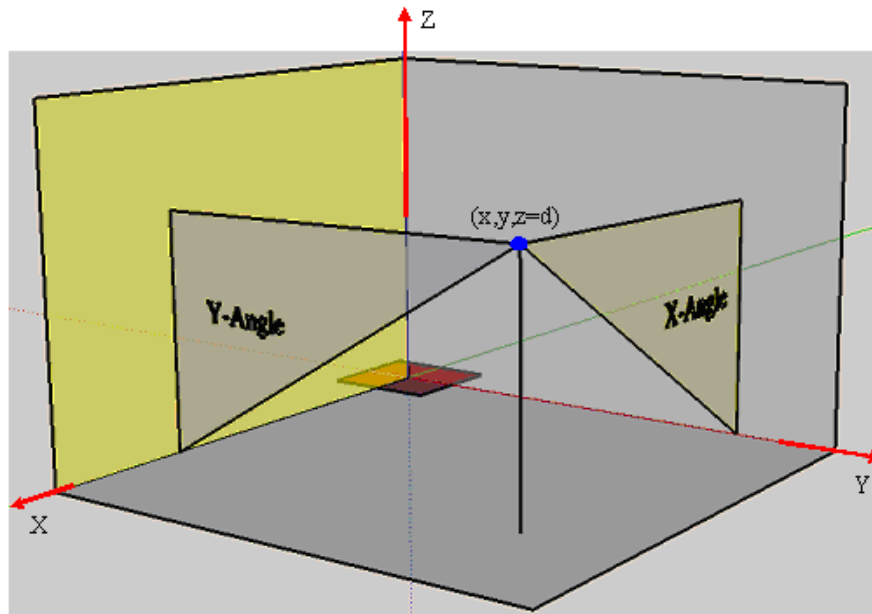
(3)

$$E(\theta_x, \theta_y) \propto \iint E(x', y', 0) e^{-in\frac{2\pi}{\lambda}[x' \cdot \tan(\theta_x) + y' \cdot \tan(\theta_y)]} dx' dy'$$

Please note that the above formula assumes that the far-field plane is far away from the near field one. OptiFDTD uses equation (3) to calculate the narrow angle far field transform.



Figure 22 Far-field angle (the red region is the near field)



Fresnel-Kirchhoff Diffraction Formula

Wide angle far field transform is based on the Fresnel-Kirchhoff diffraction formula [1].

(3)

$$E(x, y, z = d) = -\frac{i}{\lambda} \iint E(x', y', z = 0) \frac{e^{ikR}}{R} \left[\frac{1 + \cos(\vec{R}, \vec{z})}{2} \right] dx' dy'$$

Where R is the vector from near-field to far-field.

The far-field position can be expressed with far field angle the far-field distance z=d. So in the wide angle far field transform, the user needs to specify the far-field distance.



Heating Absorption

It is known that the real electromagnetic power transmitted through the closed surface S into the volume V is equal to the power loss produced by conduction current resulting in Joule heating plus the power loss resulting from polarization damping forces.

From the complex Poyntin vector theorem, the time-average heating absorption intensity is expressed as

$$w(\lambda) = \sigma(\lambda)|E(\lambda)|^2/2$$

where σ is the conductivity that maybe varied with wavelenth, E is the electrical field components.

In OptiFDTD, for each cell in a given observation area, the heating absorption intensity for each polarization then can be expressed as

$$w_{x,i,i}(\lambda) = \sigma_{x,i,j}(\lambda)|E_{x,i,j}(\lambda)|^2/2$$

$$w_{y,i,j}(\lambda) = \sigma_{y,i,j}(\lambda)|E_{y,i,j}(\lambda)|^2/2$$

$$w_{z,i,j}(\lambda) = \sigma_{z,i,j}(\lambda)|E_{z,i,j}(\lambda)|^2/2$$

$$w_{i,j}(\lambda) = w_{x,i,j}(\lambda) + w_{y,i,j}(\lambda) + w_{z,i,j}(\lambda)$$

where the subscript letter, x,y and z means the polarization direction, i and j is the position index.

Then the total heating absorption for one observation slice will be the integral of the heating absorption intensity in the volume

$$W_x(\lambda) = \int \int_{obs} w_{x,m,n}(\lambda) dudvd\tau = \left(\int \int_{obs} \sigma_{x,i,j}(\lambda)|E_{x,i,j}(\lambda)|^2 dudv \right) \cdot \frac{d\tau}{2}$$

$$W_y(\lambda) = \int \int_{obs} w_{y,m,n}(\lambda) dudvd\tau = \left(\int \int_{obs} \sigma_{y,i,j}(\lambda)|E_{y,i,j}(\lambda)|^2 dudv \right) \cdot \frac{d\tau}{2}$$

$$W_z(\lambda) = \int \int_{obs} w_{z,m,n}(\lambda) dudvd\tau = \left(\int \int_{obs} \sigma_{z,i,j}(\lambda)|E_{z,i,j}(\lambda)|^2 dudv \right) \cdot \frac{d\tau}{2}$$



Where du and dv are the mesh size in the observation plane, $d\tau$ is the third dimensional (vertical to the observation area) space step. The total heating absorption in the whole observation slice will be

$$W(\lambda) = W_x(\lambda) + W_y(\lambda) + W_z(\lambda)$$

Heating absorption calculation needs the conductivity. Basic formula between permittivity and refractive index is

$$\epsilon_r - j \frac{\sigma}{\omega \epsilon_0} = (n - jK)^2$$

So the permittivity and conductivity is

$$\begin{aligned} \epsilon_r &= n^2 - K^2 \\ \sigma &= 2nK\omega\epsilon_0 \end{aligned}$$

For Lorentz_Drude model material

$$\epsilon_{r,\infty} + \sum_{m=0}^{\dots} \frac{G_m \Omega_m^2}{\omega_m^2 - \omega^2 + j\omega\Gamma_m} = \epsilon_{r1}(\omega) - j \cdot \epsilon_{r2}(\omega) = \epsilon_r - j \frac{\sigma}{\omega \epsilon_0}$$

The conductivity can be delivered as

$$\sigma = \omega \epsilon_0 \epsilon_{r2}(\omega)$$

RCS Calculation

Consider figure 21, which depicts an observation point $\vec{P} = \vec{r}$ in the far field many wavelengths away from the near field path $\vec{r}' = z'\hat{z} + x'\hat{x}$. In this case, the Far Field can be identified as:

$$E_y(\vec{r}') = \frac{e^{j\pi/4}}{\sqrt{8\pi kr}} e^{-jkr} \oint_{C_a} \left\{ \begin{array}{l} -(\omega\mu_0)\vec{y}' \cdot \vec{J}_{ea}(r') \\ -ky'x\vec{J}_{ma}(r') \cdot \vec{r}' \end{array} \right\} e^{+jk\vec{r} \cdot \vec{r}'} dC' \quad (\text{RCS-1})$$



for TE simulation and

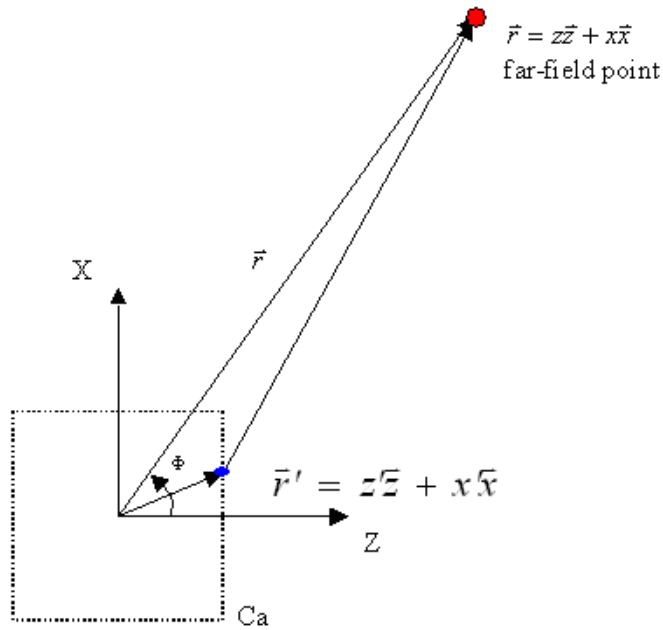
$$H_y[\vec{r}(\theta)] = \frac{e^{j\pi/4}}{\sqrt{8\pi kr}} e^{-jkr} \oint_{C_a} \left\{ \begin{array}{l} -\omega\epsilon(\hat{y} \cdot \vec{M}_{eq}) \\ +k(\hat{y} \times \vec{J}_{eq}) \cdot \hat{r} \end{array} \right\} e^{+jk\hat{r} \cdot \vec{r}'} dC' \quad (\text{RCS-2})$$

for TM simulation.

Then the bistatic radar cross section (RCS) in two dimension can be defined as:

$$\begin{aligned} \text{RCS}(\phi) &= 2\pi \cdot \frac{\text{Power scattered per unit angle in direction } \hat{r}}{\text{Incident Power per unit length}} \\ &= 2\pi \frac{|F(\phi)|^2}{|F_{inc}|^2} \end{aligned} \quad (\text{RCS-3})$$

Figure 23 Geometry of far-field point relative to the new field contour



References:

- [1] Justin Peatross and Harold Stokes, "**Physics of Light and Optics**"



Plane Wave Expansion (PWE) method

The Maxwell equation in a transparent, time-invariant, source free, and non-magnetic medium can be written in the following form:

$$\nabla \times \frac{1}{\varepsilon(\vec{r})} \nabla \times \vec{H}(\vec{r}) = \frac{\omega^2}{c^2} \vec{H}(\vec{r}), \quad (1)$$

where $\varepsilon(\vec{r})$ is the space dependent dielectric function, c is speed of light in vacuum, and $\vec{H}(\vec{r})$ is the optical magnetic field vector of a definite frequency ω with time dependence $e^{i\omega t}$. This equation is sometimes called the master equation [1], and represents a Hermitian eigen-problem, which would not be applicable if the wave equation were derived in terms of the electric field.

The Bloch theorem says that, due to the infinite periodicity, the magnetic field will take the form:

$$\vec{H}(\vec{r}) = e^{i\vec{k}\vec{r}} \vec{h}_k(\vec{r}), \quad (2)$$

where $\vec{h}(\vec{r}) = \vec{h}(\vec{r} + \vec{R})$ for all combinations of lattice vectors \vec{R} . Thus, we end up with the master equation in operator form:

$$(\nabla + i\vec{k}) \times \left\{ \frac{1}{\varepsilon(\vec{r})} (\nabla + i\vec{k}) \right\} \times \vec{h}_k = \frac{\omega^2}{c^2} \vec{h}_k \quad (3)$$

This is the fundamental equation, which needs to be solved. The equation is transformed into a finite problem by expanding the magnetic field in a finite basis of simple plane waves. Different approaches can be explored to solve the final discretized problem, e.g. [2] and [3]. The result of solving the discretized problem is the dispersion relationship between the frequencies of the modes and wave vector \vec{k} , usually plotted in the form of a band diagram.



References:

- [1] J.D. Joannopoulos, R.D. Meade, and J.N. Winn, "Photonic crystals, Molding the flow of light", Princeton University Press, 1995.
- [2] S.G. Johnson, J.D. Joannopoulos, "Block-iterative frequency-domain methods for Maxwell's equations in a planewave basis", Optics Express 8, no.3, p.173-190, 2000.
- [3] S.Guo, S.Albin, "Simple plane wave implementation for photonic crystal calculations", Optics Express 11, no.2, p.167-175, 2003.



Power Transmittance Calculation with VB Scripting

Access to the simulation results data of Observation objects is a critical feature required for layout sweep simulations and optimization of designed devices. During the simulations, observation objects collect time domain data. The time domain data are stored in the Analyzer file. The OptiFDTD Analyzer provides all tools necessary for post-simulation analysis of the results. However, this requires manual interaction with the application. In order to provide the means for automated processing of the simulation results, VB Script interfaces have been designed, which access the required data. For more information, see “Power Transmittance Calculations - Observation Line” of the **VB Script Reference Guide** for a description and usage details for the VB script functions and interface.



References:

FDTD basic references

- [1] Yee, K. S., "Numerical solution of initial boundary value problems involving Maxwell's equations in isotropic media," *IEEE Transactions on Antennas and Propagation*, 302-307, (1966).
- [2] Chu, S. T., Chaudhuri, S.K., "A finite-difference time-domain method for the design and analysis of guided-wave optical structures," *Journal of Lightwave Technology*, 2033-2038, (1989).
- [3] Taflove, A., Hagness, S., "Computational Electrodynamics: The Finite-Difference Time-Domain Method," Second edition, Artech House, Boston, (2000).

Material models

- [1] Ziolkowski, R. W., "Incorporation of microscopic material models into FDTD approach for ultrafast optical propagation," *IEEE Transactions on Antennas and Propagation*, 375-391, (1997).
- [2] Liang, T., Ziolkowski, R. W., "Dispersion effects on grating-assisted output couplers under ultrafast pulse excitations", *Microwave and Opt. Tech. Lett.*, **17**, 17-23, (1998).

Anisotropic Perfectly Matched Layer (Anisotropic PML) boundary conditions

- [1] Bérenger, J. P., "A perfectly matched layer for the absorption of electromagnetic waves," *Journal of Computational Physics*, **114**, 185-200, (1994).
- [2] Gedney, S. D., "An anisotropic perfectly matched layer absorbing media for the truncation of FDTD lattices," *IEEE Transactions on Antennas and Propagation*, 1630-1639, (1996).
- [3] Taflove, A., "Advances in Computational Electrodynamics—The Finite-Difference Time-Domain Method", Artech House, Boston, Ch. 5, (1998).

Nonlinearity

- [1] Ziolkowski, Richard W., Judkins, Justin B., "Full-wave vector Maxwell equation modeling of the self-focusing of ultrashort optical pulses in a nonlinear Kerr medium exhibiting a finite response time", *J. Opt. Soc. Am. B*, **2**, 186-198 (1993).
- [2] Ziolkowski, Richard W., Judkins, Justin B., "Nonlinear finite-difference time-domain modeling of linear and nonlinear corrugate waveguides", *J. Opt. Soc. Am. B*, **9**, 1565-1575, (1994).
- [3] Ziolkowski, Richard W., Judkins, Justin B., "Applications of the nonlinear finite difference time-domain(NL-FDTD) method to pulse propagation in nonlinear media: self-focusing and linear-nonlinear interfaces", *Radio Science*, 901-911, (1993).
- [4] Ziolkowski, Richard W., "The incorporation of microscopic material models into the FDTD approach for ultrafast optical pulse simulations", *IEEE Trans. On Antenna and Propagation*, **3**, 375-391, (1997).
- [5] Joseph, Rose M., Taflove, Allen, "FDTD Maxwell's equations models for nonlinear electrodynamics and optic", *IEEE Trans. On Antenna and Propagation*, **3**, 364-374, (1997).



- [6] Goorjian, Peter M., Taflove, Allen, Joseph, Rose M., "Computational modeling of Femtosecond optical soliton from Maxwell's equation", IEEE Journal of Quantum electronics, **10**, 2416-2422, (1992).
- [7] Joseph, Rose M., Taflove, Allen, " Spatial soliton deflection mechanism indicated by FD-TD Maxwell's equations modeling", IEEE Photonics Technology Letters, **10**, 1251-1254, (1994).





Tutorials

The following are tutorial lessons. Each one concerns different applications and features. The first four lessons are recommended for first time users to learn the basics of OptiFDTD.





Introduction to the layout designer concept

This lesson is designed to familiarize you with the OptiFDTD layout designer concept. The same basic steps need to be followed to layout any device in OptiFDTD. This document will guide you through these steps and provide you with a detailed explanation.

OptiFDTD comes as 4 main applications:

1. Layout Designer – This is where you define your structure and simulation conditions.
2. Profile Designer – This is used to define the materials and profiles used in the simulation.
3. Simulator – This program loads the designer file and performs the simulation. The simulator is started from the layout designer.
4. Analyzer – This program is used to view the results and perform some post processing. As soon as the simulation is done, the simulator will ask if you would like to open the analyzer.

This document focuses on using the layout designer. To start an OptiFDTD project, your first step will be to open up the layout designer. From here the process of defining a layout begins.

[Figure 1](#) is a flow chart that illustrates the main steps for building a layout.

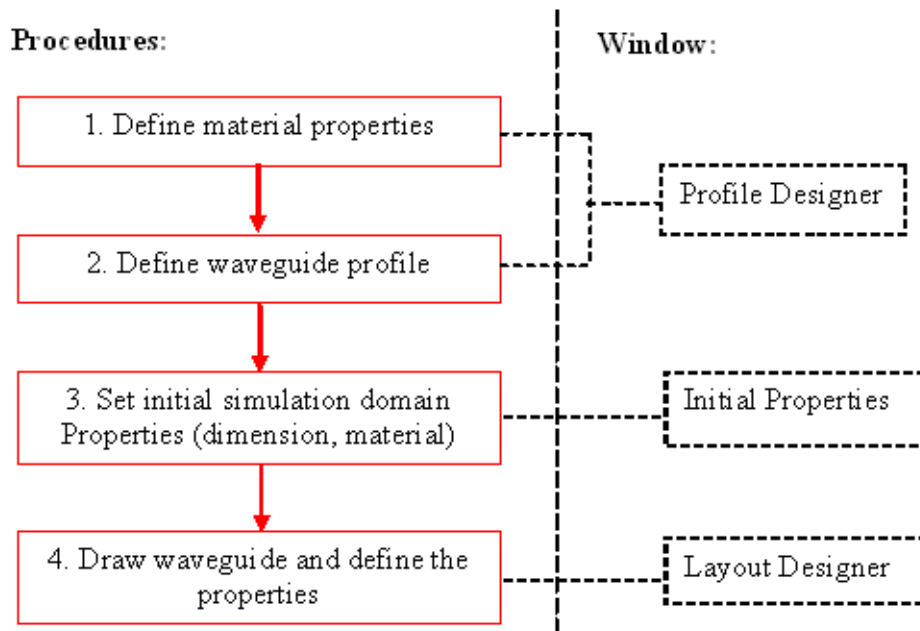


Figure 1 Flow chart for building a Layout

The simulation domain can be 2D (finite xz -area) or 3D (xyz -volume) depending on the simulation that you choose. For 3D simulations, the domain is divided into 2 parts called substrate and cladding for historical reasons. The boundary between substrate and cladding define $y = 0$. Structures such as waveguides and lenses are placed within this domain. An example layout to illuminate the design concept is illustrated in [Figure 2](#). We can see the substrate is the volume defined by $y < 0$ and the cladding is the volume defined by $y > 0$. The substrate and cladding each have a material associated with them. They define the default background material that other structures are imbedded in. There is a channel waveguide consisting of two rectangular layers; it is suspended in the cladding volume and extends along the z -direction. Another fiber waveguide consisting of two circular fiber layers is imbedded in the substrate and also extends along z -direction.

The cross-sections of the rectangular waveguide and the fiber are what we call profiles. By combining profiles with waveguide that are drawn in the layout, we can define 3D shapes in the simulation domain.



The following is the relevant data for this layout

1) Material that will be used in the project

- a. Substrate material: $n=2.0$
- b. Cladding material: $n=1.0$ (Air)
- c. Material for channel waveguide layer 1: $n=3.0$
- d. Material for channel waveguide layer 2: $n=2.5$
- e. Material for fiber waveguide core layer: $n=3.0$ (same as channel waveguide layer 1)
- f. Material for fiber waveguide cladding layer: $n=2.5$ (same as channel waveguide layer 2)

2) Waveguide profile (waveguide cross section) and material

- a) Channel profile
 Layer 1: width: $1.5\mu\text{m}$; thickness: $1.0\mu\text{m}$; Material: $n=3.0$
 Layer 2: width: $1.0\mu\text{m}$; thickness: $0.5\mu\text{m}$; Material: $n=2.5$
- b) Fiber profile
 Core layer: radius: $0.5\mu\text{m}$; Material: $n=3.0$
 Cladding layer: radius: $1.0\mu\text{m}$; Material: $n=2.5$

3) Simulation domain properties.

- a) Length: $8\mu\text{m}$ (z-direction: $0\mu\text{m} \rightarrow +8\mu\text{m}$);
- b) Width : $6\mu\text{m}$ (x-direction: $-3\mu\text{m} \rightarrow +3\mu\text{m}$)
- c) Substrate layer thickness: $3\mu\text{m}$ (y-direction: $-3\mu\text{m} \rightarrow 0\mu\text{m}$), material: $n=2.0$
- d) Cladding thickness: $3\mu\text{m}$ (y-direction: $0\mu\text{m} \rightarrow 3\mu\text{m}$), material: $n=1.0$ (Air)

4) Waveguide properties

- a) Channel waveguide
 Position: $(1.5, 1.0, 0)\mu\text{m} \rightarrow (1.5, 1.0, 8)\mu\text{m}$
 Width: $1.5\mu\text{m}$; Thickness: $1.5\mu\text{m}$
- b) Fiber waveguide
 Position: $(-1.5, 1.5, 0)\mu\text{m} \rightarrow (1.5, -1.5, 8)\mu\text{m}$
 Width: $2.0\mu\text{m}$



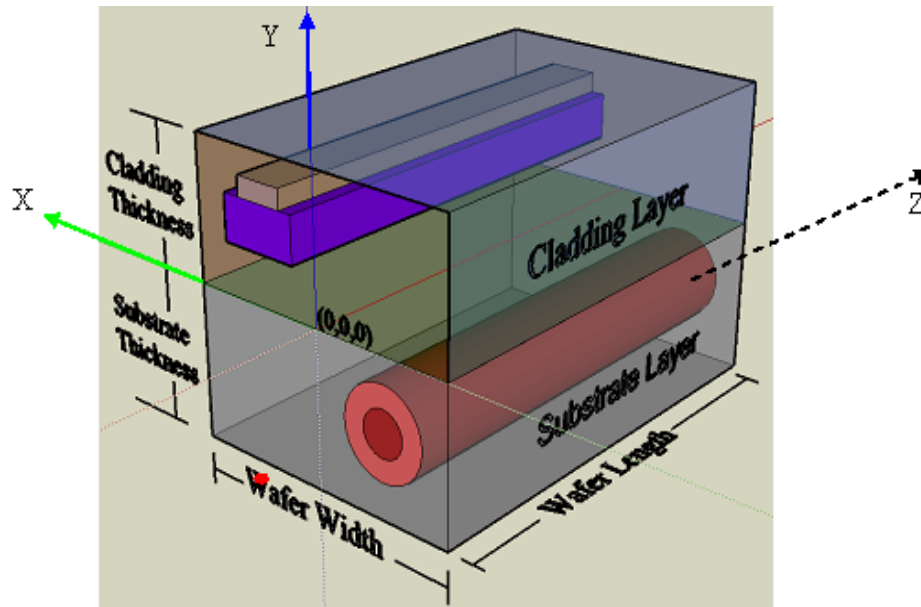


Figure 2 Example Layout

The following detailed steps are used to build the project layout demonstrated in [Figure 2](#).

Step Action

1 Open *OptiFDTD Waveguide layout Designer*

From the **Start** menu, select **Programs >Optiwave Software > OptiFDTD >**

Waveguide Layout Designer. *OptiFDTD_Designer* window opens (see [Figure 3](#))

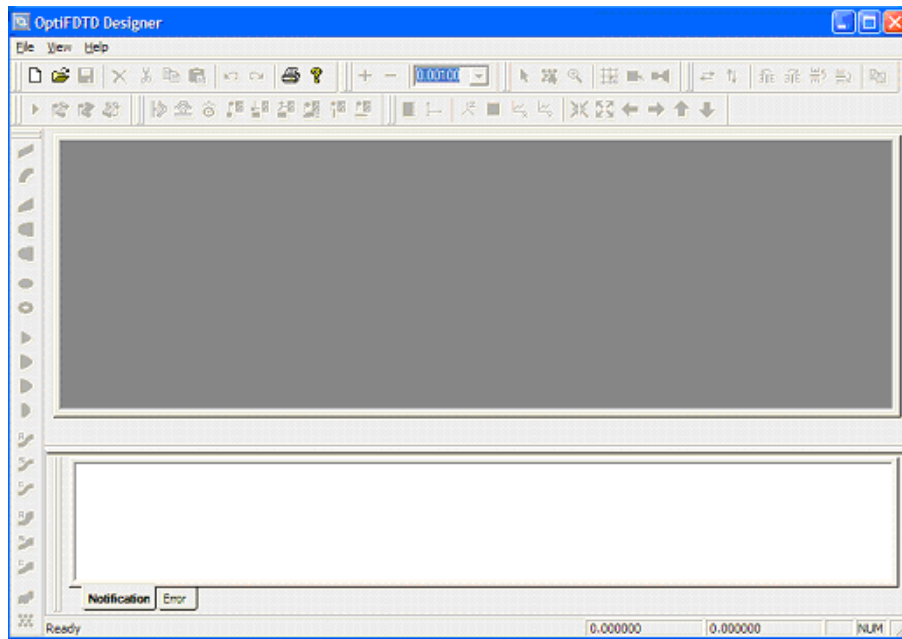


Figure 3 OptiFDTD Designer (No layout)

2 Create a new project

From the **OptiFDTD_Designer File** menu, select **New**. The **Initial Properties** dialog box appears. (See [Figure 4](#))

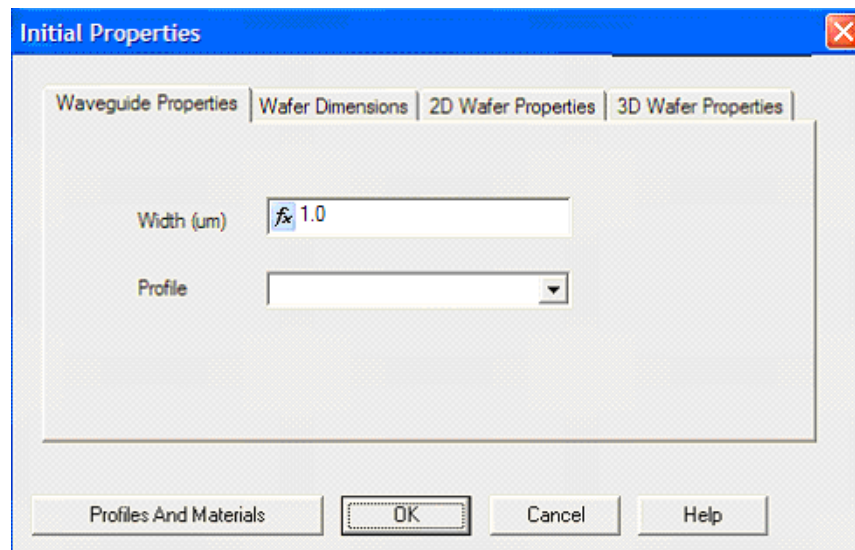


Figure 4 Initial Properties

3 Start Profile Designer

To define the material(s) and waveguide profile(s) that will be used in the project,

Click **Profiles and Materials** button in **Initial Properties** Dialog. *The Profile Designer OptiFDTD* opens. (See [Figure 5](#))



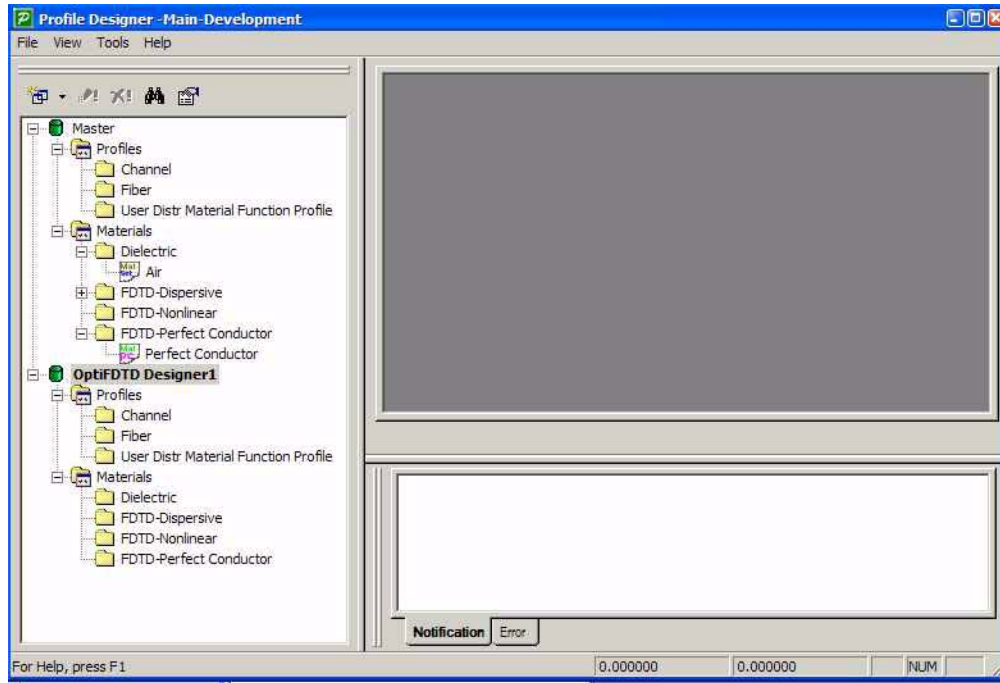


Figure 5 Profile designer

Note:

- (1) **Profile Designer** can work independently. It can be started from the start menu of OptiFDTD, or started in the layout designer.
- (2) Material and waveguide profile defined in the "**Master**" folder can be worked as database

4 Define material in Profile Designer

Perform the following sub-steps to define the material that will be used in the example project.

- (1) In the directory under **OptiFDTD_Designer1**, **Materials** folder, right-click the **Dielectric** folder. A context menu appears (see [Figure 6](#)).



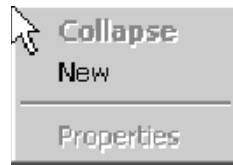


Figure 6 Context Menu

(2) Select **New**. The **Dielectric** dialog box appears (see [Figure 7](#)).

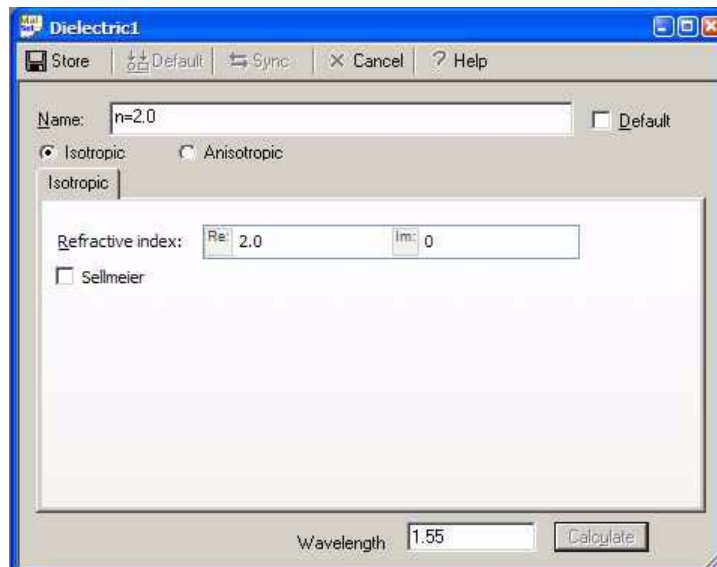


Figure 7 Dielectric dialog box

(3) Type the following information

Name: **n=2.0**

refractive index (isotropic)(Re): **2.0**

(4) To save the material, click **Store**. Material **n=2.0** will be listed in the Dielectric folder.

(5) Repeat above sub steps (1) - (4) to define second material as

Name: **n=2.5**

refractive index (isotropic)(Re): **2.5**

(6) Repeat above sub steps (1) - (4) to define third material as

Name: **n=3.0**

refractive index (isotropic)(Re): **3.0**



- (7) **Air** material is the OptiFDTD default material that will be always exist in the material folder. If **Air** material does not appear in the material folder list, please follow the step (1) - (4) to define this **Air** material:

Name: **Air**

Constant refractive index (isotropic)(Re): **1.0**

Explain:

- (1) Right Click on the defined material in the Material folder list, A *context menu* appears. you can **copy**, **remove**, **Edit**, **rename** and **check properties** of this material by select the corresponding item.
- (2) You can also select one defined material from the material folder list and drag it into corresponding other material folder in Master folder or other project folder (when you open more projects)

5 Define Channel profile

Channel profile is a waveguide cross section that may contain single or multiple rectangular shapes.

- (1) In the directory under **OptiFDTD_Designer1**, under the **Profiles** folder, right click the **Channel** folder. A *context menu* appears.
- (2) Select **New**. The **Channel Profile** dialog box appears (see [Figure 8](#)).



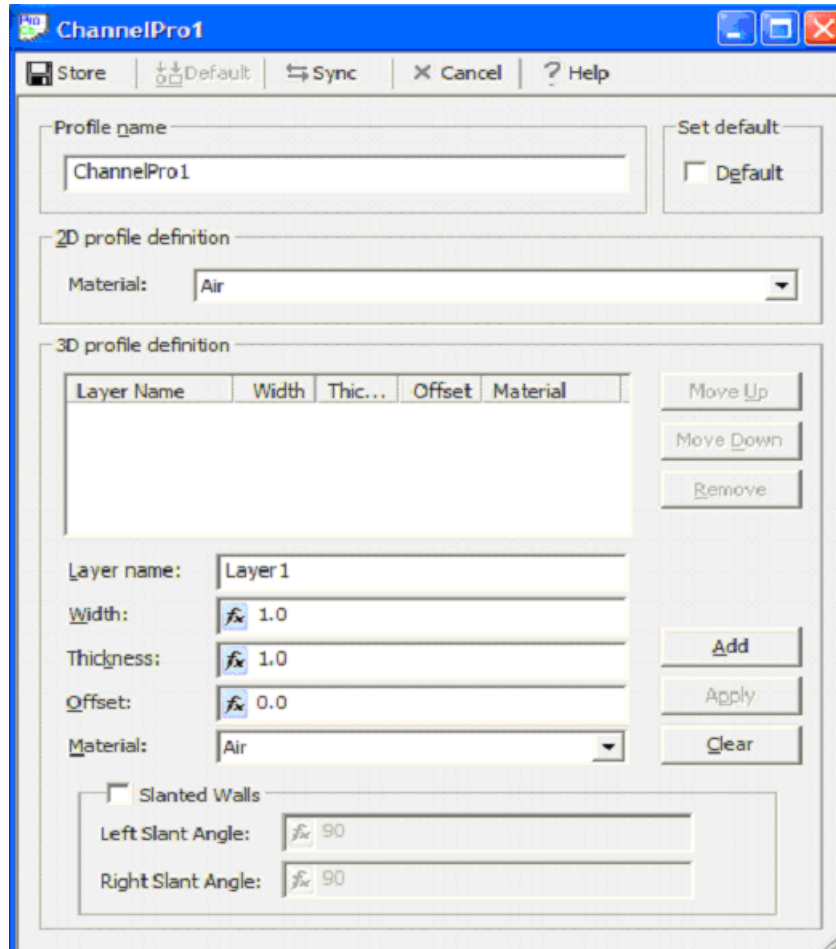


Figure 8 Channel Profile dialog box

(a)

- (3) Type the following Profile name: **ChannelPro1**.
- (4) To define the 2D profile, in the **Material** list under **2D profile definition**, select **N=3.0**.

Explain:

- (a) 2D Profile will be used as 2D simulation.
- (b) Only the material is needed for the 2D profile definition. The 2D waveguide shape will be defined in the layout window

- (5) To define the 3D channel profile, under **3D profile definition**:

(a) Type the following information (refer to Figure 7):

Layer name: **Layer1**



Width: **1.5**
 Thickness: **1.0**
 Offset: **0.**

(b) In the **Material** list, select **n=3.0**

(c) Click **Add**.

(d) Repeat above step (a)-(c) to add another layer that has the following properties.

Layer name: **Layer2**

Width: **1.0**

Thickness: **0.5**

Offset: **0.**

(e) To save the defined channel profile, click **Store**, **ChannelPro1** will be listed under the Channel profile folder.

Note:

(a) Now we have created a waveguide cross section as shown in [Figure 9](#).

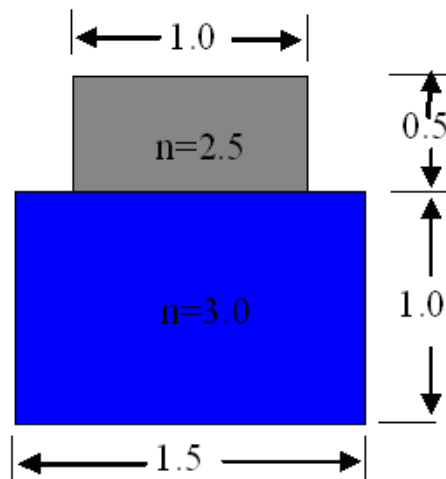


Figure 9 Two layer channel profile

(b) Each layer's dimension is a ratio value. The waveguide real dimension will be set in the waveguide properties dialog box in the layout window.

(c) "Offset" can make the layers shift along the horizontal direction.

6 Define fiber profile

Fiber profile is a waveguide cross section that may contain single or multiple circular or elliptical shapes.

- (1) In the directory under **OptiFDTD_Designer1**, under the **Profiles** folder, right click the **Fiber** folder. *A context menu appears.*
- (2) Select **New**. *The **Fiber Profile** dialog box appears (see [Figure 10](#)).*
- (3) Type the following Profile name: **FiberPro1**.
- (4) To define the 2D fiber profile, in the **Material** list under **2D profile definition**, select **N=3.0**.
- (5) To define the 3D fiber profile, under **3D profile definition**:

(a) Type the following information (*refer to [Figure 11](#)*):

Layer name: **Core**
Rx: **0.5(x-directional radius)**
Ry: **0.5(y-directional radius)**

(b) In the **Material** list, select **n=3.0**

(c) Click **Add**.

(d) Repeat above step (a)-(c) to add another layer that has the following properties.

Layer name: **Cladding**
Rx: **1.0**
Ry: **1.0**
Material: n=2.5

(e) To save the defined channel profile, click **Store**, **FiberPro1** will be listed under the **Fiber Profile** folder.



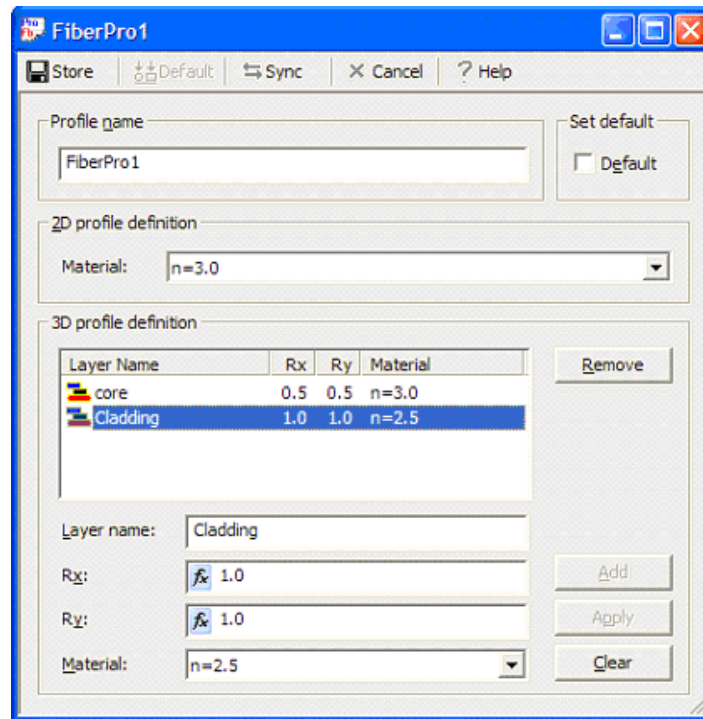


Figure 10 Two layers fiber profile

Note:

(a) Now we have created a fiber waveguide cross section as shown in [Figure 11](#).

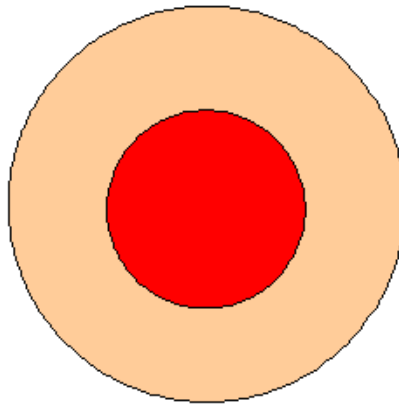


Figure 11 Sketch for Two Layers fiber profile

- (b) The Input dimension is a ratio value. The real fiber waveguide dimension can be re-set in the layout window.

The material and waveguide cross-section have now been defined. We can either leave the Profile designer window open or close it. In the next step we return to the initial properties dialog box to finish the layout dimension setting.

7 Set initial simulation domain properties

- (1) In the Initial Properties dialog Box, click **Waveguide Properties** button.
 - (a) In the **Width** input box, input the initial waveguide width as $1.5\mu\text{m}$

Explain: This is the waveguide width default setting, i.e. when you draw a waveguide in the layout window; the drawn waveguide will have this default width.

- (b) From the **Profile** list, Select **ChannelPro1** as the default waveguide profile

Note: When you draw a waveguide direction, this channel profile will be linked to your drawn waveguide

- (2) In the **Initial Properties** dialog box, click **Wafer Dimension** button.



- (a) Input 8.0 (μm) in the **Length** input box
- (b) Input 6.0 (μm) in the **Width** input box

Note:

- (a) In OptiFDTD, we refer to the whole simulation domain as the wafer
 - (b) **Length** direction is designated as z-direction. And the z-directional coordination for the layout will be from 0 μm to 8 μm for the current setting
 - (c) **Width** direction is designated as x-direction. And the x-directional coordination for the layout will be from -3 μm to 3 μm for the current setting
- (3) In the **Initial Properties** dialog box , Click **3D Wafer Properties**
- (a) In the Substrate area, input the following information
Material: **n=2**; thickness: 3 (μm)
 - (b) In the Substrate area, input the following information
Material: **Air**; thickness: 3 (μm)

Explain:

- (1) **3D Wafer Properties** control the y direction simulation domain properties. By default, Optiwave automatically set the wafer has two layers in y-direction. One layer is named "**Substrate**", and another layer is named "**Cladding**". Here the word "**Substrate**" and "**Cladding**" may not be your real layout's substrate and cladding.
- (2) Interface between substrate and cladding layer will be the y-directional original point. The **Substrate thickness** can be set as zero to make the whole simulation domain as one background material, later in the layout window, user can fill in other waveguide shape with different materials.
- (3) For the current setting, the y-direction coordination for the layout will be from -3 μm to +3 μm .

i.e, from -3 μm to 0 μm , it is the substrate layer with material as n=2, and from 0 μm to 3 μm , it is the cladding layer.

- (4) In the **Initial Properties** dialog box , Click **2D Wafer Properties**. In the Wafer Refractive Index region set, the material as **Air**

Explain:

This step will be set the back ground material for 2D layout.

The initial properties settings have now been completed. The user can always modify these settings by selecting **Wafer Properties** or **Profile and Material** in the edit menu of the OptiFDTD Designer.

8 Start OptiFDTD Designer window

Click **OK** in the Initial Properties Dialog box, **OptiFDTD Designer** appears (see [Figure 12](#)).

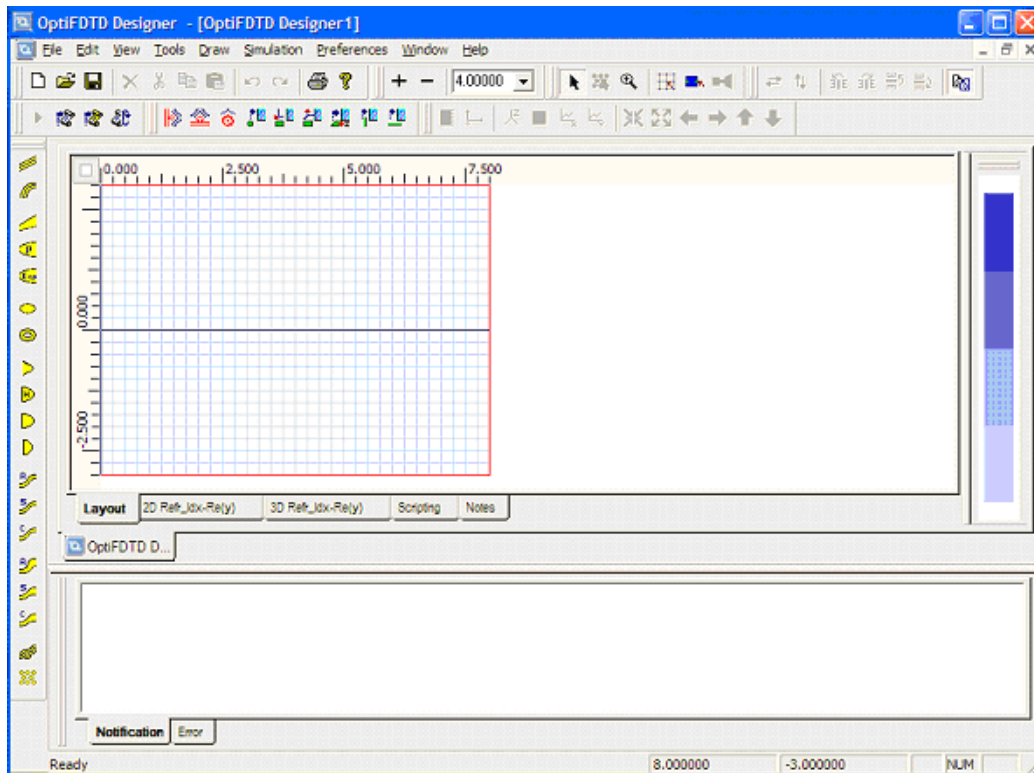


Figure 12 OptiFDTD layout Designer

Explain

- (1) **OptiFDTD Designer** window is the xz- plane viewer of your layout.
- (2) For the first time user, we recommend that all the shortcut toolbars are visible. Also for your convenience the waveguide shape shortcut toolbar can be moved to the left side of the layout window.
- (3) Click shortcut toolbar "+" or "-" to zoom in or zoom out the layout window.
- (4) Try to click on the different menu to view the software provided items.



- 9 Draw the channel waveguide in the layout window
- (1) From the **Draw** menu, select **Linear Waveguide**.
 - (2) In the layout window, drag the linear waveguide from the start point to the end point. *A linear waveguide appears in the layout window.*
Note: Release the **Linear Waveguide** selection tool by clicking the **Select tool** after the **Linear Waveguide** is drawn in the layout.
 - (3) To adjust the position and the shape of the waveguide, in the layout window, double-click the Linear Waveguide. *The **Linear Waveguide Properties** dialog box appears (see Figure 13).*

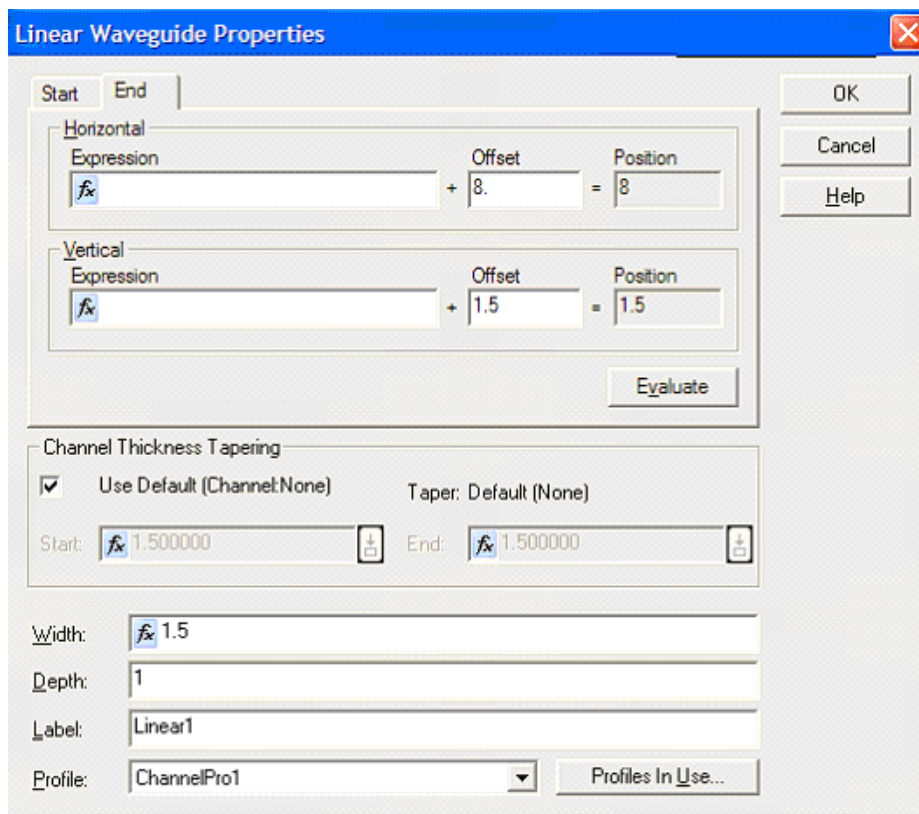


Figure 13 Channel waveguide Properties.

- (4) Click the **Start** tab and type the following values
 Horizontal offset (μm): **0**
 Vertical offset (μm): **1.5**

(5) Click the **End** tab and type the following values:

Horizontal offset (μm): **8.0**

Vertical offset (μm): **1.5**

Explain

- (a) Here the **Start** and **End** tab control the waveguide x and z coordinator position.
 - (b) Horizontal direction is z-direction; Vertical direction is x-direction.
 - (c) In OptiFDTD, all the input boxes marked “fx” can accept variable and expression input. Click **Evaluate** to see the final value of the expression.
- (6) Input 1.5 (μm) In the **Width** box

Explain: This is the channel waveguide Width

(7) Input 1 (μm) In the **Depth** box

Explain: This is the channel waveguide y-direction position. It is the distance from the channel waveguide bottom to the y-directional original point.

(8) Input **Linear1** in the **Label** box. This is the object name

(9) Input **ChannelPro1** in the **Profile** box

Explain: This will link the linear waveguide trends with the defined channel profile.

(10) Click **OK** to finish the Channel waveguide setting.

Explain:

- (a) In summary, the values for **Start Horizontal**, **Start Vertical**, and **Depth** control the waveguide start point coordinator (1.5, 1.0, 0.0) μm . The values for **End Horizontal**, **End Vertical**, and **Depth** control the waveguide end point coordinator (1.5, 1.0, 8.0) μm . The width and thickness controls the waveguide dimension.
- (b) If the user wants to set the waveguide thickness (y-direction thickness), please unselect “**Use Default**” checkbox under the Channel Thickness Tapering region. The user can then put a start position thickness and an end position thickness. If **Use Default** checkbox is select, then the waveguide thickness will be the total thickness that is defined in the profile designer.



10 Draw the Fiber waveguide in the layout window

- (1) From the **Draw** menu, select **Linear Waveguide**.
- (2) In the layout window, drag the linear waveguide from the start point to the end point. *A linear waveguide appears in the layout window. Release the Draw mode by select the select toolbar*
- (3) To adjust the position and the shape of fiber waveguide, in the layout window, double-click the Linear Waveguide. *The **Linear Waveguide Properties** dialog box appears*
- (4) In the **Linear Waveguide Properties** dialog box, Select **FiberPro1** as the profile from the **Profile** list box (See [Figure 14](#)).

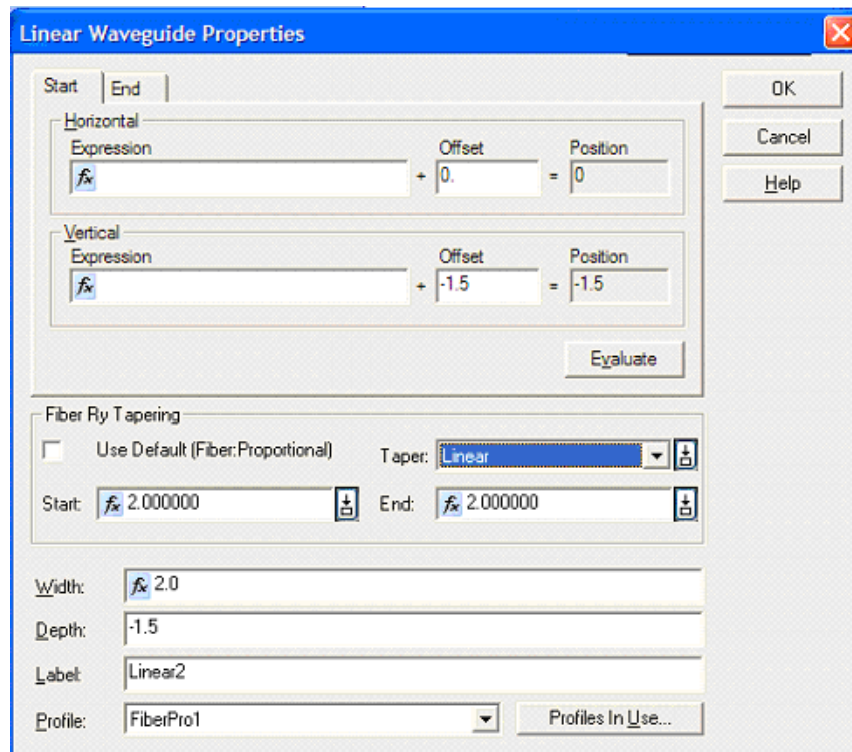


Figure 14 Fiber waveguide properties

- (5) Click the **Start** tab and insert the following values
 Horizontal offset (μm): **0**
 Vertical offset (μm): **-1.5**

- (6) Click the **End** tab and type the following values:
Horizontal offset (μm): **8.0**
Vertical offset (μm): **-1.5**
- (7) In the **Fiber Ry Tapering** region, unselect **User Default**, select **Linear** in the Taper list box. Set the **Start** and **End** values as 2.0 (the Fiber's thickness in the y direction)
- (8) Input the value 2.0 (μm) in the **Width** box (the Fiber's Width in the x-direction)
- (9) Input the value -1.5 (μm) in the Depth box (the Fiber's center position in the y direction).
- (10) Input **Linear2** as the **Lable** name.
- (11) Click **OK** to finish the Fiber waveguide setting

Now the sample layout has been created. Please review the following for the further understanding of the layout concept

Explain

- (a) Please note that the OptiFDTD designer environment is a 2D plane for x-z view as shown in [Figure 15](#). Each object may have the different depth reference to y-direction original position, but the OptiFDTD designer will show all these objects in this x-z plane top view as shown in figure 15.



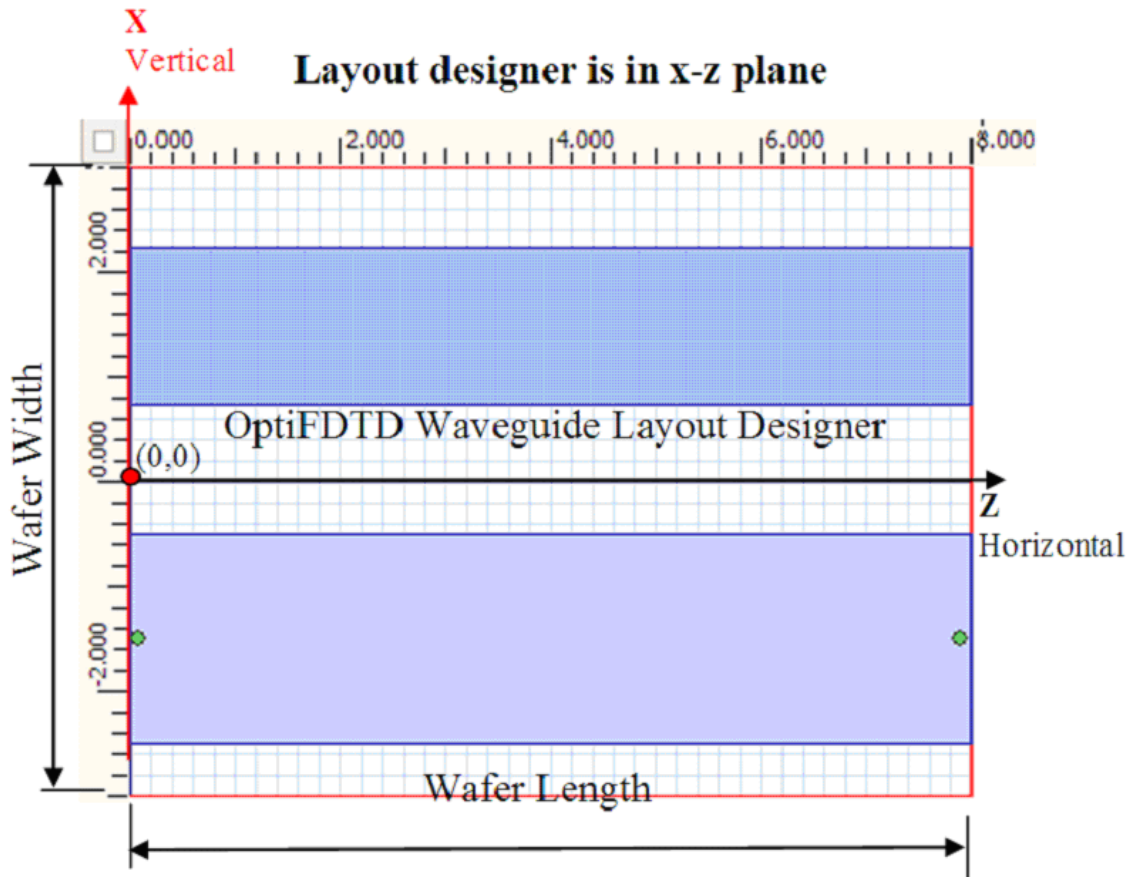


Figure 15 OptiFDTD designer for the example layout.

(b) [Figure 16](#) is the sketch for the OptiFDTD Designer concept from the example layout.

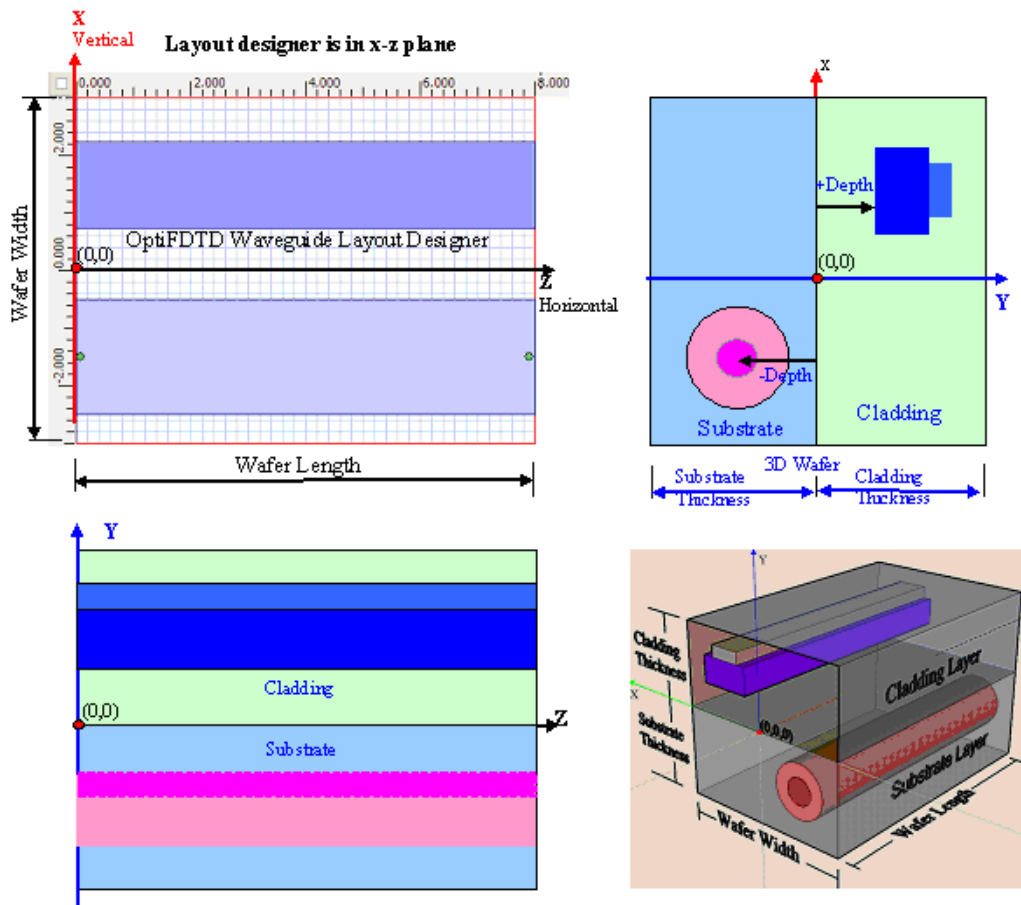


Figure 16 Sketch for the designed layout

- (c) OptiFDTD designer works only in the x-z plane, but a slice viewer is provided for you to observe the refractive index distribution in any slice in xy plane, yz plane and xz plane. To do this, Please set and input plane first, and Click **3D_Refr_Idx_Re(y)** button that is under the layout window. You can specify the slice position and orientation to view to layout See Figure 17 (a)-(c).

Note: The refractive index image resolution is determined by the OptiFDTD simulation mesh size. Click **Simulation Parameters** in the Simulation menu to reset the mesh size.



- (d) To modify the material or the simulation domain. Please click “ **Profile and Material** ” or the Wafer Properties to open the corresponding interface.

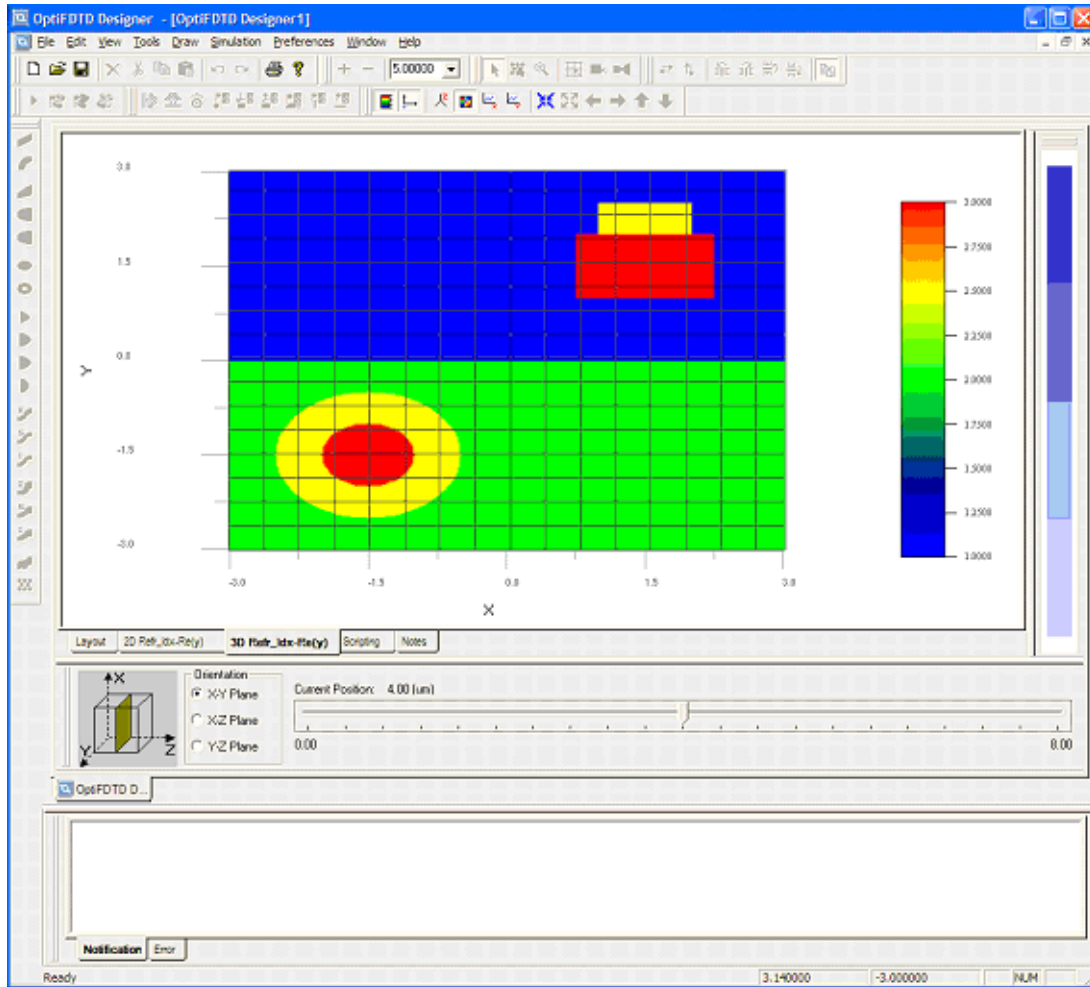


Figure 17 (a) Refractive index distribution in xy plane at $z=4.00\mu\text{m}$



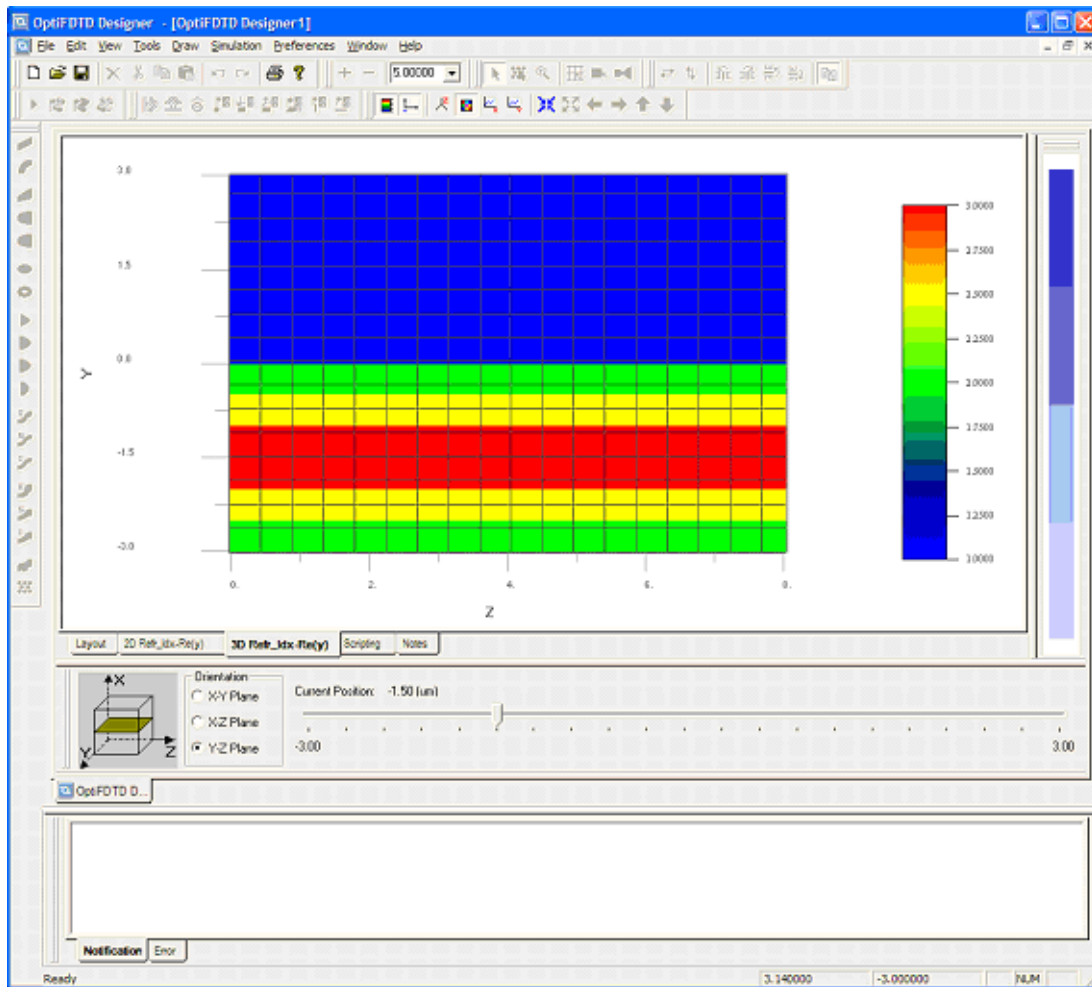


Figure 18 (b) Refractive index distribution in yz plane at $x=-1.5\mu\text{m}$



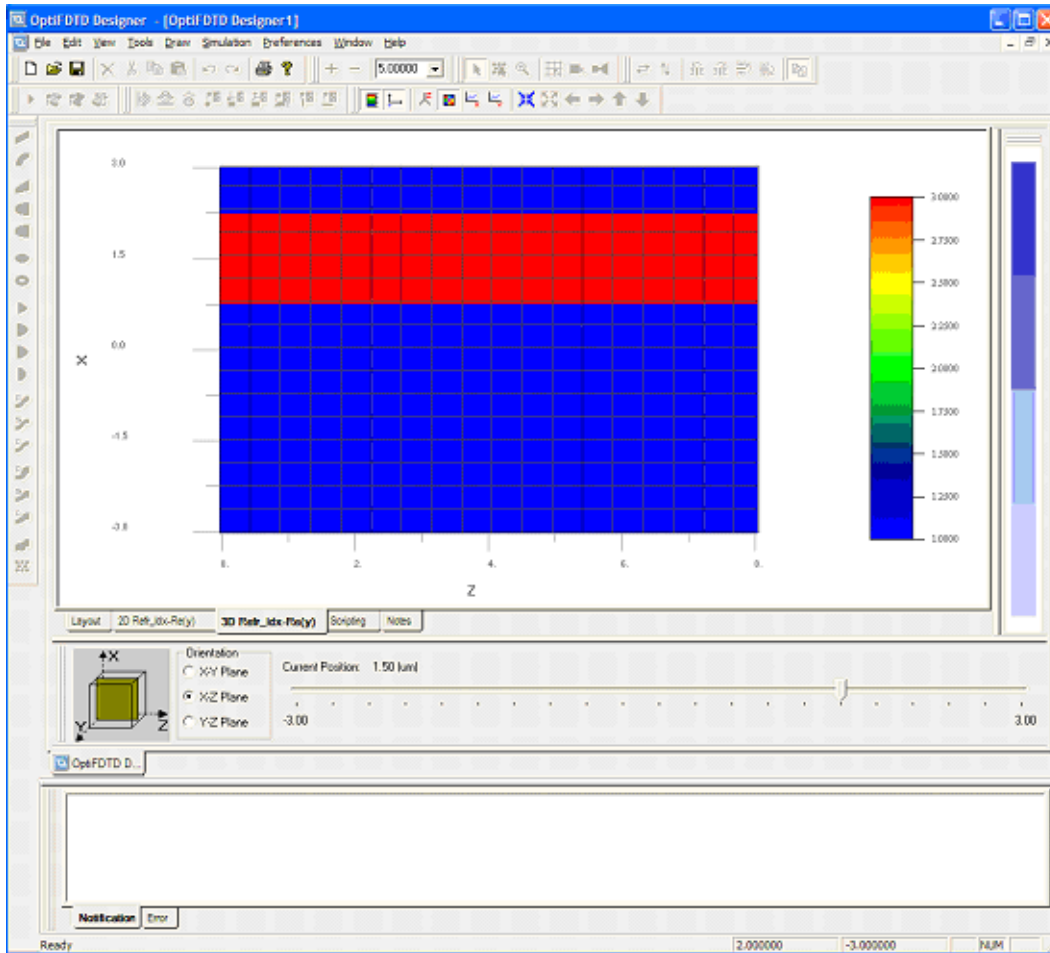


Figure 19 (C) Refractive index distribution in xz plane at $y=1.5\mu\text{m}$



Know the difference between 32-bit and 64-bit simulations

OptiFDTD provides two types of FDTD simulations:

- 32-bit simulations (performed by 32-bit Simulators).
- 64-bit simulations (performed by 64-bit Simulators).

These simulation options differ in certain aspects of supporting features or.

Memory

The most important difference between these two simulator types is the memory limitation imposed on 32-bit simulators. All the 32-bit applications may utilize up to 2GB-4GB of memory for its purposes, dependent on the operating system.

In case of 64-bit applications (simulators), this limit is in the range of Tera-Bytes. In the current Windows 64-bit this limit is around 16TB, which is far beyond RAM capacity supported by standard PC configurations.

Operating System

The 32-bit simulations can be executed under Windows 32-bit and Windows 64-bit operating systems. In case of Windows 32-bit, the operating system can provide to the simulator up to 2GB-3GB of memory, while the remaining 2GB-1GB is used by the operating system. Under Windows 64-bit, the operating system can provide the 32-bit simulator with up to 4GB of memory, while it will utilize another ~4GB for its operating system memory mapping needs.

In case of 64-bit simulators, they can be executed only under Windows 64-bit operating system. One cannot execute a 64-bit application under a 32-bit operating system.

Processor

All the references to 64-bit Windows operating systems assume usage of a processor supporting EM64T architecture. In layman terms it means "hardware support for 32-bit and 64-bit applications". The currently manufactured Intel or AMD processors support this architecture, for example Intel's Core 2 based multi-core processors.

Summary

In short - the main difference between the 32-bit and 64-bit simulations is that 64-bit simulators are capable of processing much larger designs. Due to the amount of data volume processed and generated by 64-bit simulators, the approach to the simulation result handling has changed.

The notes below describe the main differences.

— Layout size

- 32Bit simulation can only use maximum 2GB of RAM. This means for a 3D simulation, the maximum mesh point number that can be handled will



be roughly 300X300X300. When the mesh size exceeds this value, 64bit simulation is recommended.

- Time domain dynamic response
 - 32bit simulation shows the dynamic field response in **Simulator** window
 - 64bit simulation does not show the dynamic field response. Simulation process (percentage of the simulation) is displayed. The snapshot for time domain response in the certain time step for user selected observation area/line/point can be saved and viewed by Optiwave graph viewer
- Volume DFT field results (steady state response)
 - 32bit simulators calculate and record volume DFT field response (steady state response) for center wavelength
 - 64bit simulators do not store the DFT field response for the whole volume anymore. However, the steady state response is calculated and stored for Observation Area/Line/Point for user-defined wavelength range. This data can be observed in the Analyzer, after completion of the simulations.
- Observation Detector and Spectrum Analysis
 - 32bit simulations will record all the time domain response in the Observation detector (observation area, line). User can specify any wavelength to perform the DFT spectrum analysis.
 - 64bit simulations perform the spectrum analysis for observation line and observation area in simulator. No time domain response is recorded for Observation line and area. Spectrum results, for user pre-defined wavelength, are saved to analyzer (result) file. In the Analyzer, the user can select a wavelength from the previously defined list and observe the corresponding spectral results in observation area analysis. The user may define a wavelength range in the Layout Designer, in the “64-bit Simulation Parameters” dialog box (click the **Spectrum** button).
 - One must set an observation detector (Observation Point, Observation Line, and Observation Area) to collect calculation results for 64bit simulation.
- Simulation
 - 32bit FDTD simulation supports single processor.
 - 2D 64bit FDTD simulation support single processor in OptiFDTD 8.0.
 - 3D 64bit FDTD simulation support multi-processor (core)
 - 2D TFSF excitation is only supported in 2D 32bit simulation in OptiFDTD 8.0
- Tutorial lessons
 - Tutorial lessons specify the 32bit simulation to demonstrate the product features. However, one can always use the 64-bit simulations to perform calculations, or simulate an equivalent example configured for 64-bit simulations. Typically, the 64bit simulations are faster.
 - If you use a 64-bit simulation instead of 32-bit one, then make sure that the following items are addressed:
 - Please define an Observation Area/Line to collect steady state response, transmission function and reflection function
 - If the input wave is Gaussian Modulated Continuous Wave, please define the wavelength range (click on the “Spectrum” button) in the “64-bit Simulation Parameters” dialog box.



KNOW THE DIFFERENCE BETWEEN 32-BIT AND 64-BIT SIMULATIONS

This chapter is to help you familiarize yourself with the OptiFDTD Designer environment. Please use the following lessons for more detailed simulations on each project.



KNOW THE DIFFERENCE BETWEEN 32-BIT AND 64-BIT SIMULATIONS



Lesson 1—Getting started

The OptiFDTD software has seven interdependent modules:

- **OptiFDTD_Designer**—Create the photonic devices to model
- **OptiFDTD_Simulator**—Perform the FDTD simulation and DFT analysis
- **OptiFDTD_Analyzer**—Post-process the simulated data
- **FDTD Band Solver**—Generate band diagram for photonic crystal
- **PWE Band Solver**- Band diagram analysis by PWE method
- **Cross Section Layout Designer**- Design Layout Cross Section and perform mode analysis
- **Tool Box**- Allows different post-date analysis

This lesson describes how to start using OptiFDTD to perform FDTD simulation. The procedures are:

- **Create a new project**
 - Opening OptiFDTD_Designer
 - Initializing the project
 - Opening the Waveguide Profile Designer
 - Defining the material
 - Defining the 2D and 3D channel profile
 - Setting up the initial properties
- **Create a design**
 - Drawing a Linear Waveguide
 - Drawing a Ring Waveguide
- **Set up the Input Plane**
 - Inserting the Input Plane
- **Observe the Refractive Index Distribution**
 - Observing the Refractive Index Distribution
- **Set up observation points, areas, and lines**
 - Setting up an Observation Point
- **Run the simulation**
 - Setting up the simulation parameters
 - Running the 32bit simulation



- Analyze the simulation results
 - Opening OptiFDTD_Analyzer
 - Analyzing the results
 - Calculating the Mode Overlap Integral (MOI)
 - Calculating the Input Overlap Integral (IOI)
 - Calculating the Input Overlap Integral Scanner (IOIS)
 - Calculating the Far Field Transform
 - Performing the Observation Object Analysis
- Export results
 - Exporting results



Create a new project

The following lesson uses a micro-ring resonator as a sample design.

Note: The corresponding project file can also be found in the **Sample** file folder, `Sample02_3D_Ring_Resonator.fdt`.

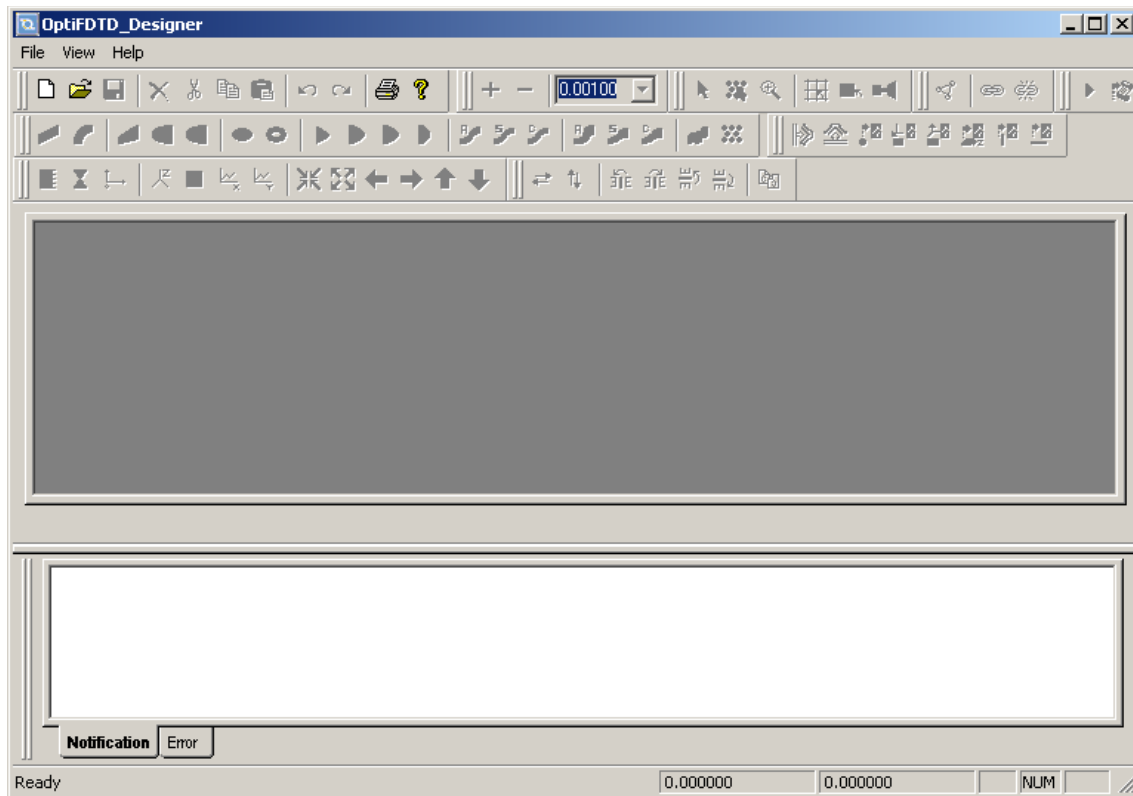
To create a new project, perform the following procedures.

Opening OptiFDTD_Designer

Action

- To open **OptiFDTD_Designer**, from the **Start** menu, select **Programs > Optiwave Software > OptiFDTD > Waveguide Layout Designer**. *OptiFDTD_Designer* appears (see [Figure 1](#))

Figure 1 OptiFDTD_Designer

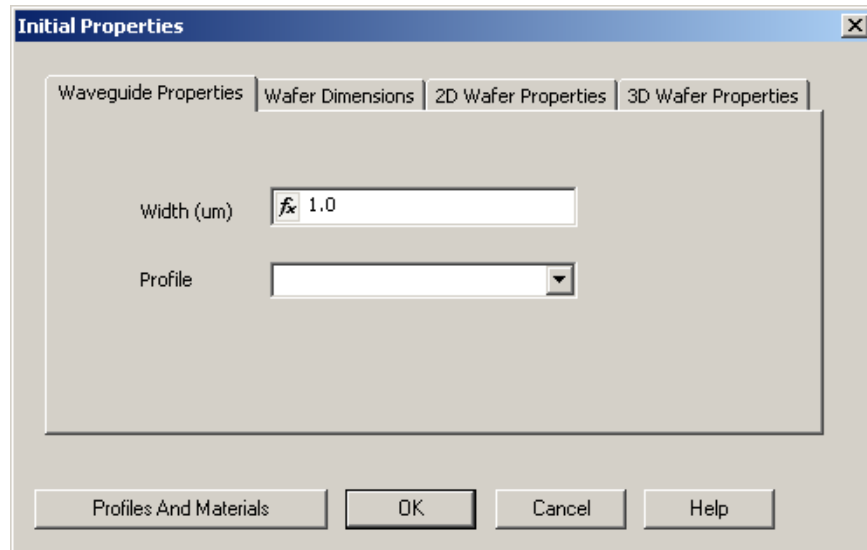


Initializing the project

Action

- To initialize the project, from the **OptiFDTD_Designer File** menu, select **New**.
The **Initial Properties** dialog box appears (see [Figure 2](#))

Figure 2 Initial Properties dialog box



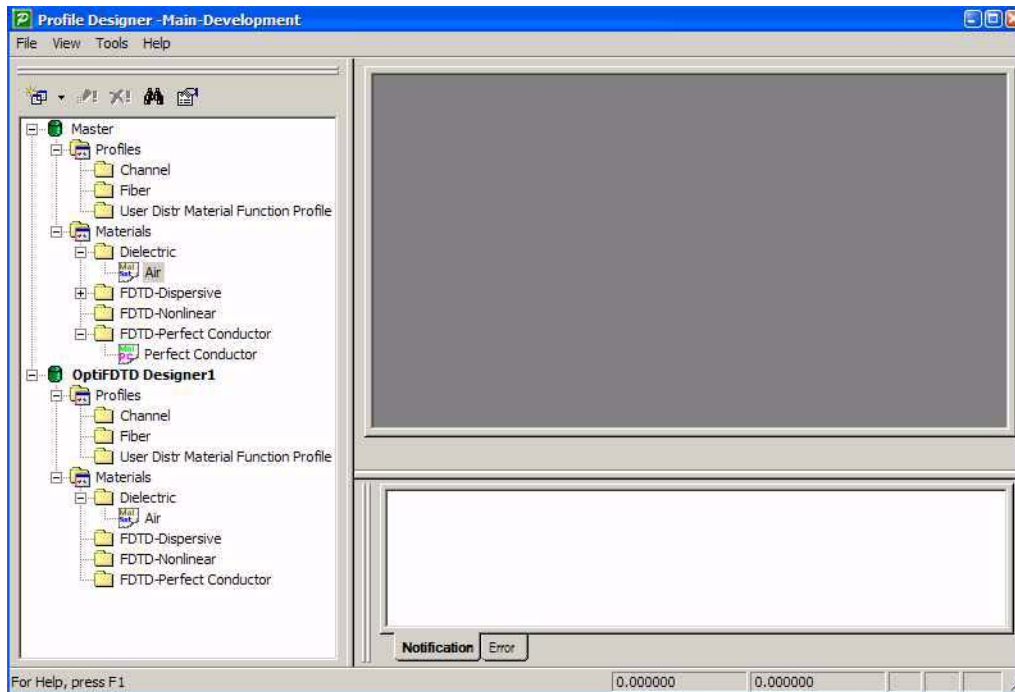
Opening the Waveguide Profile Designer

Step Action

- 1 To define the materials, in the **Initial Properties** dialog box, click **Profiles And Materials**.
The **Waveguide Profile Designer** opens (see [Figure 3](#)).



Figure 3 Waveguide Profile Designer

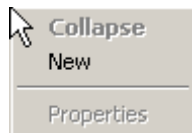


Note: You can also open the **Waveguide Profile Designer** from the **Start** menu (see “Opening OptiFDTD_Designer” on page 93).

Defining the material

- | Step | Action |
|------|--|
| 1 | In the directory under OptiFDTD_Designer1 , Materials folder, right-click the Dielectric folder.
<i>A context menu appears (see Figure 4).</i> |

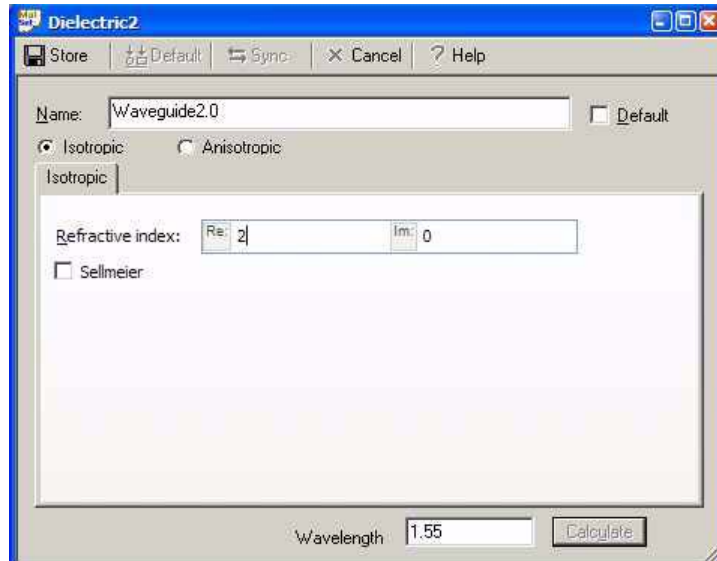
Figure 4 Context menu



- | | |
|---|--|
| 2 | Select New .
<i>The Dielectric dialog box appears (see Figure 5).</i> |
|---|--|



Figure 5 Dielectric dialog box



- 3 Type the following information
Name: **Waveguide2.0**
Refractive index (isotropic)(Re): **2.0**
- 4 To save the material, click **Store**.
Note: Repeat steps 2 to **Note:** to create additional Dielectric materials.

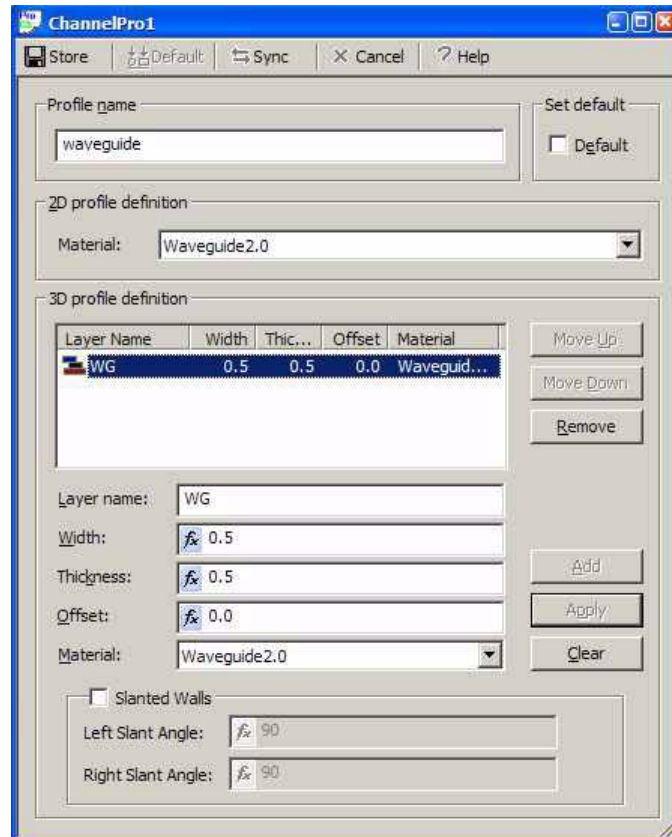
Defining the 2D and 3D channel profile

- | Step | Action |
|------|---|
| 1 | In the directory under OptiFDTD_Designer1 , under the Profiles folder, right-click the Channel folder.
<i>A context menu appears.</i> |



- 2 Select **New**.
The **Channel Profile** dialog box appears (see [Figure 6](#)).

Figure 6 ChannelPro1 dialog box



- 3 Type the following Profile name: **waveguide**
- 4 To define the 2D profile, in the **Material** list under **2D profile definition**, select **Waveguide2.0** (refer to [Figure 6](#)).
- 5 To define the 3D profile, under **3D profile definition**:
- Type the following information (refer to [Figure 6](#)):
Layer name: **WG**
Width: **0.5**
Thickness: **0.5**
Offset: **0.**
 - In the **Material** list, select **Waveguide2.0**
 - Click **Add**.



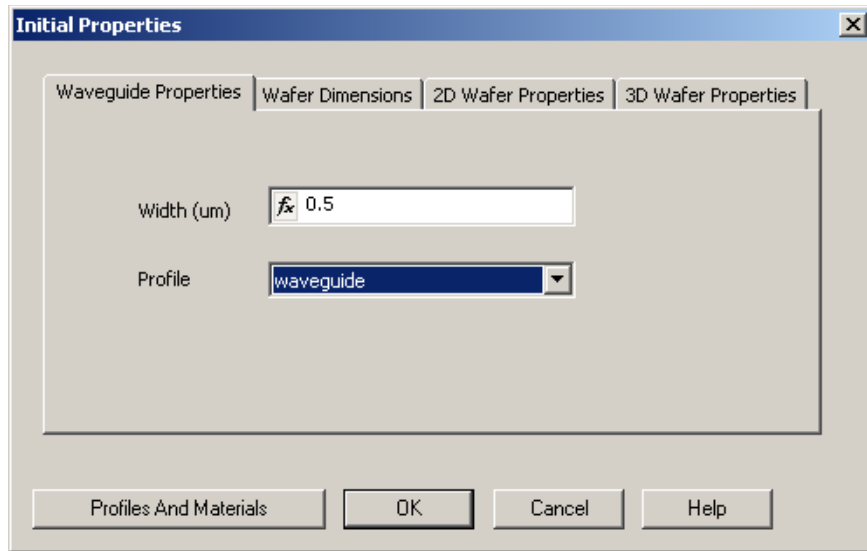
- 6 To save the channel profile, click **Store**.
Waveguide appears in the Channel folder in the directory, in the dialog box title bar, and on the tab at the bottom of the layout.
- 7 To return to OptiFDTD_Designer, either minimize or close the Waveguide Profile Designer.

Setting up the initial properties

To set up the initial properties, perform the following procedure.

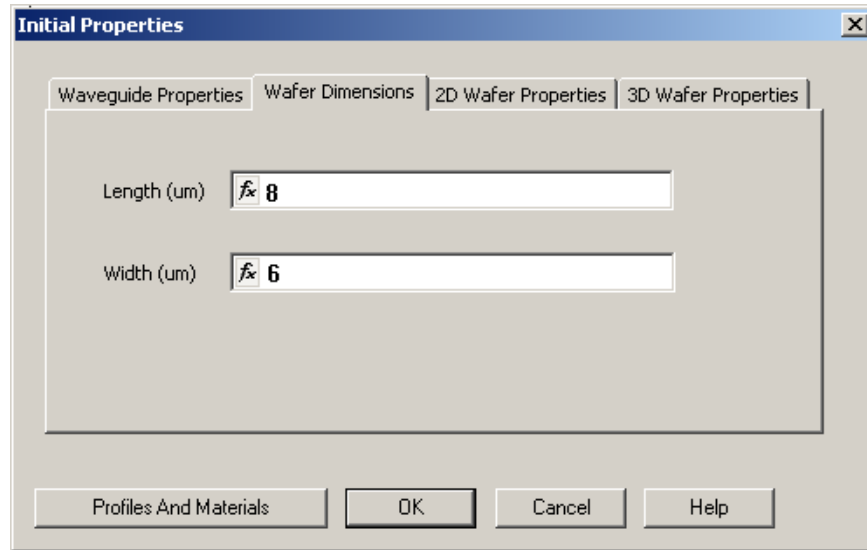
- | Step | Action |
|-------------|---|
| 1 | In the Initial Properties window, click the Waveguide Properties tab. |
| 2 | Type the following value (see Figure 7):
Width (μm): 0.5 |
| 3 | From the profile list, select waveguide (Figure 7). |

Figure 7 Initial Properties dialog box—Waveguide Properties tab

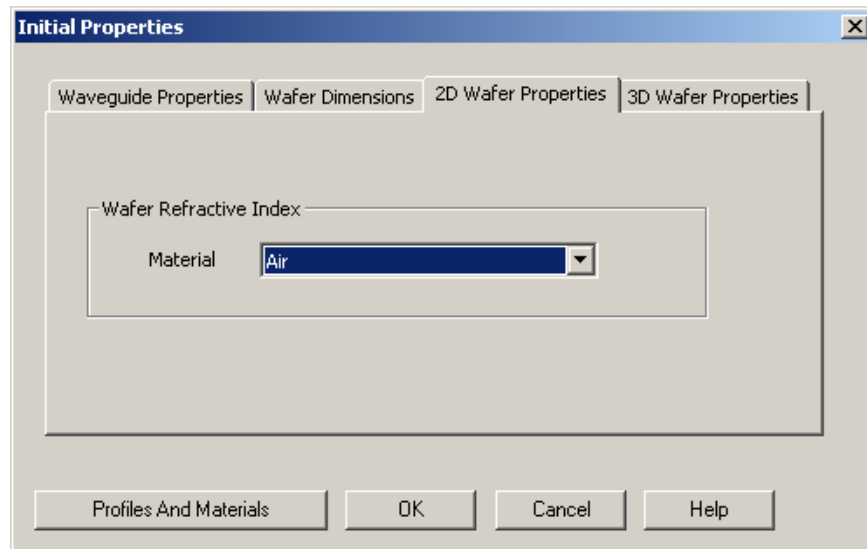


- 4 Click the **Wafer Dimensions** tab.
- 5 Type the following value (see [Figure 8](#)):
Length (μm): 8
Width (μm): 6



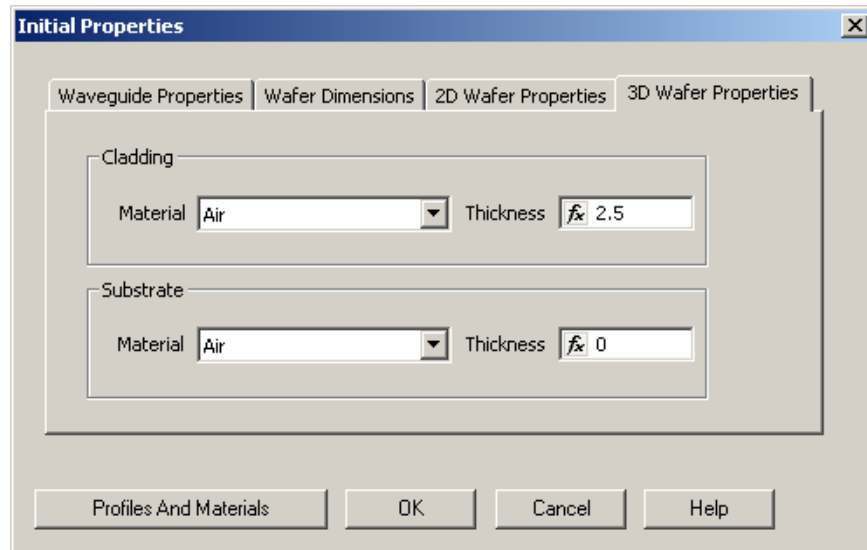
Figure 8 Initial Properties dialog box—Wafer Dimensions tab

- 6 Click the **2D Wafer Properties** tab.
- 7 From the **Material** list, select **Air** (see [Figure 9](#)).

Figure 9 Initial Properties dialog box—2D Wafer Properties tab

- 8 Click the **3D Wafer Properties** tab (see [Figure 10](#)).

Figure 10 Initial Properties dialog box—3D Wafer Properties tab



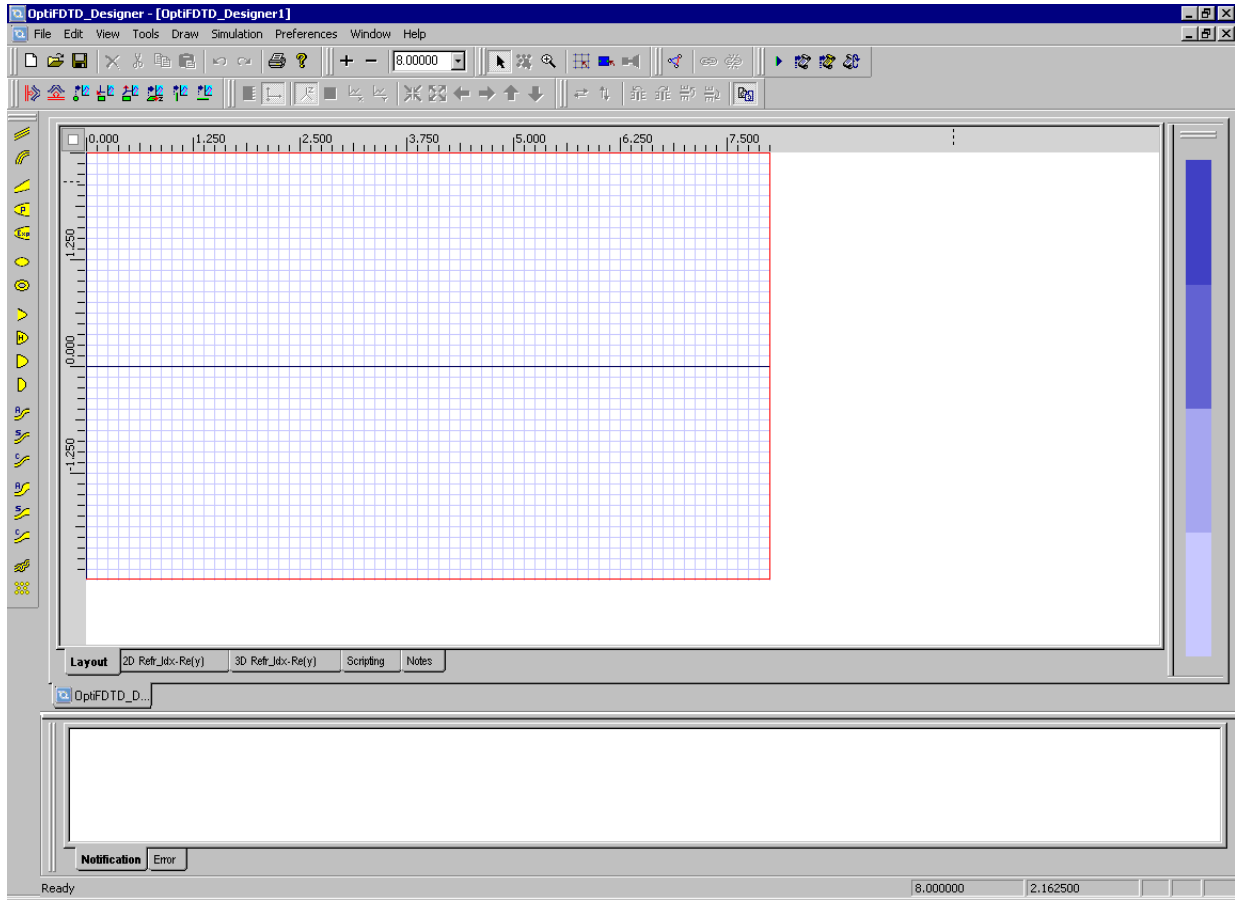
- 9 Under **Cladding**, from the **Material** list, select **Air**.
- 10 Under **Substrate**, from the **Material** list, select **Air**.
- 11 Type the following values:
 - Cladding thickness (μm): **2.5**
 - Substrate thickness (μm): **0**

Note: Cladding and substrate are two layers in the Y-direction that can have different materials and thicknesses. The Y-axis origin is at the interface between the substrate and cladding.

- 12 To finish the initial properties setup, click **OK**.
The layout window appears (see [Figure 11](#)).

Note: Click **Zoom** tool to enlarge the layout window.

Figure 11 Layout window



Create a design

To draw a micro-ring resonator, first draw a linear waveguide by performing the following procedures.

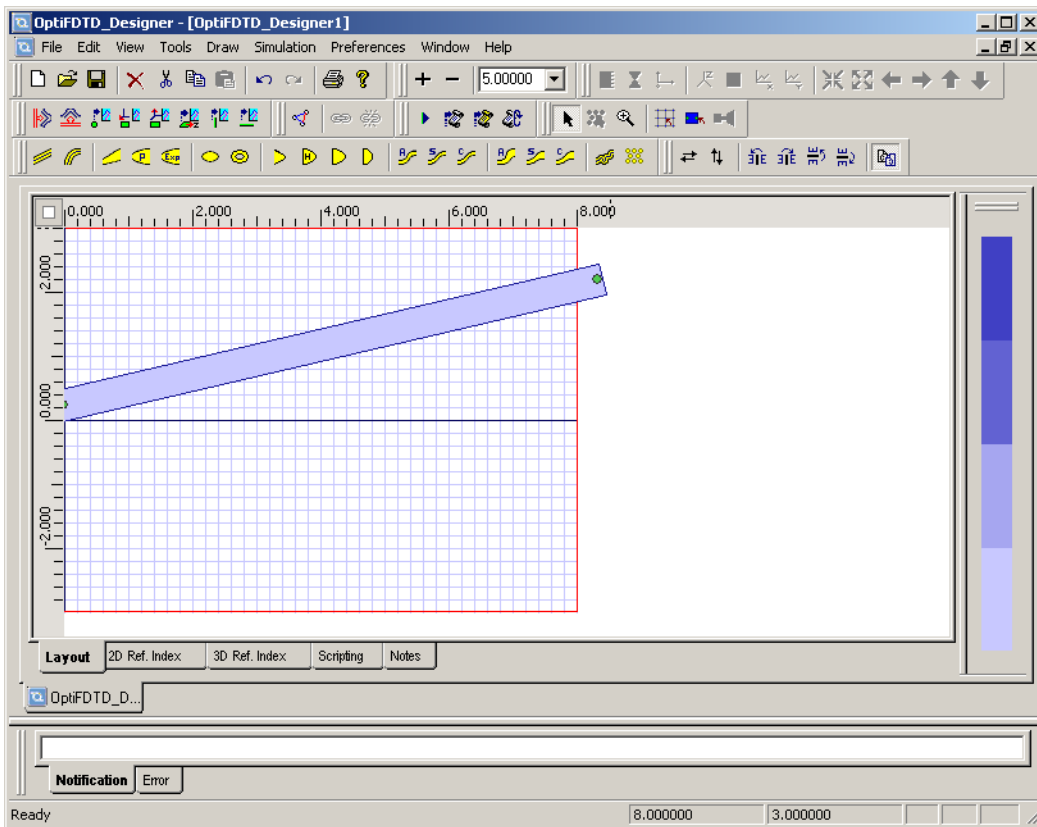
Drawing a Linear Waveguide

Step Action

- 1 From the **Draw** menu, select **Linear Waveguide**.
- 2 In the layout window, drag the linear waveguide from the start point to the end point.
A linear waveguide appears in the layout window (see [Figure 12](#)).

Note: Release the **Linear Waveguide** selection tool by clicking the **Select tool** after the **Linear Waveguide** is drawn in the layout.

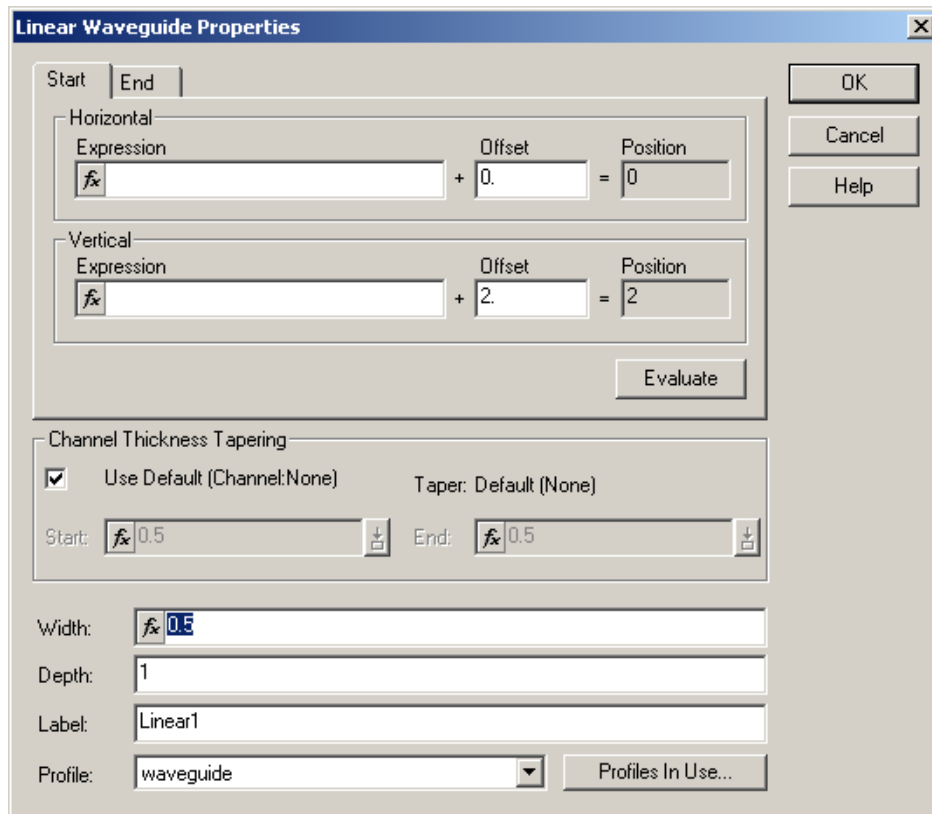
Figure 12 Linear Waveguide



- 3 To adjust the position and the shape of the waveguide, in the layout window, double-click the Linear Waveguide.
The **Linear Waveguide Properties** dialog box appears (see [Figure 13](#)).



Figure 13 Linear Waveguide Properties dialog box



- 4 Click the **Start** tab and type the following values:
 - Horizontal offset (μm): 0
 - Vertical offset (μm): 2.0
 - Width (μm): 0.5
 - Depth (μm): 1.0
 - Label: **linear1**
 - Channel Thickness Tapering: **Use Default (Channel: None)**
- 5 Click the **End** tab and type the following values:
 - Horizontal offset (μm): 8.0
 - Vertical offset (μm): 2.0

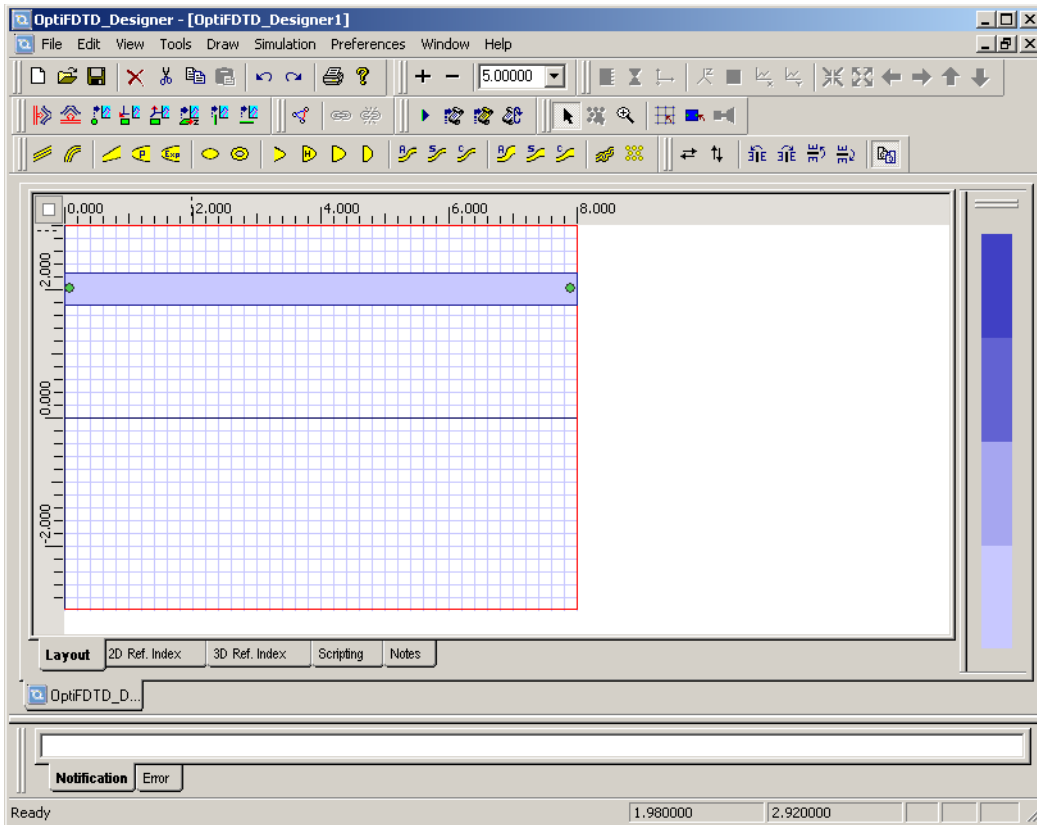
Note:

- You can also set a variable and even the expression—click **Evaluate** to see the final value of the expression.
- Horizontal means the z-direction.
- Vertical means the x-direction.
- Depth means the y-direction.



- 6 From the **Profile** list, select **Waveguide**.
- 7 To save the new values and update the Linear Waveguide, click **OK**.
The modified Linear Waveguide appears in the new position (see [Figure 14](#)).

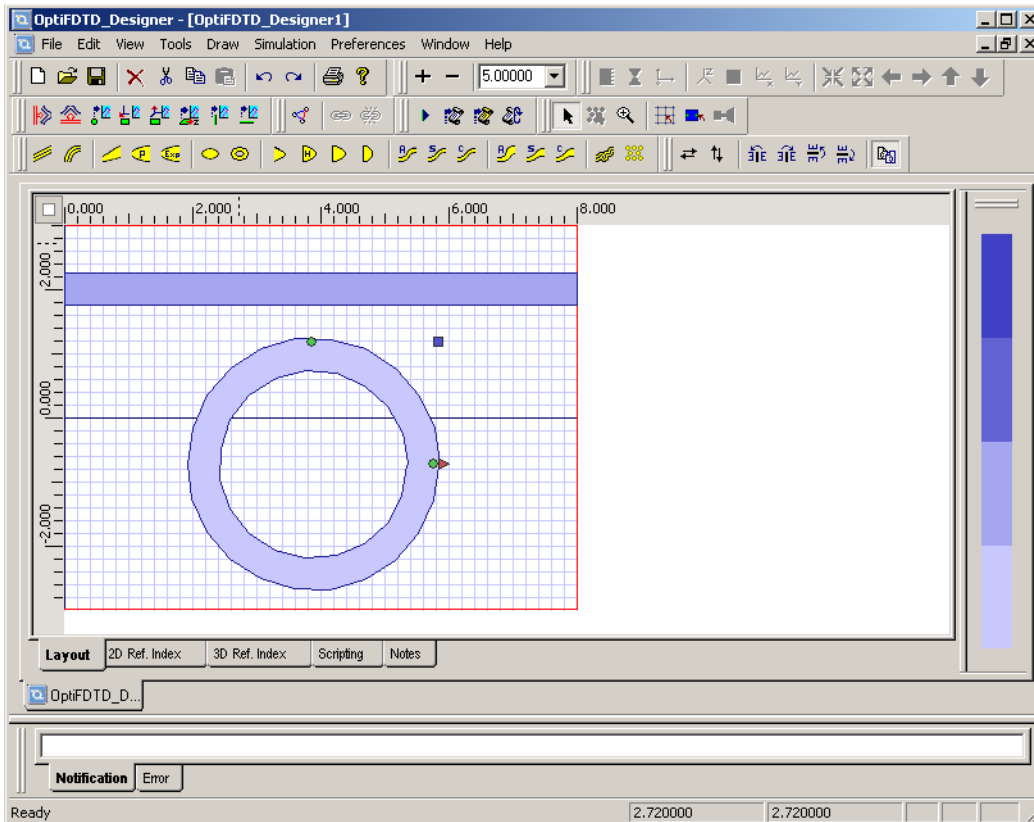
Figure 14 Modified Linear Waveguide



Drawing a Ring Waveguide

- | Step | Action |
|------|---|
| 1 | From the Draw menu, select Ring Waveguide . |
| 2 | In the layout window, drag the Ring Waveguide from what will be the center, to a point which will be the radius of the outside ring (see Figure 15). |

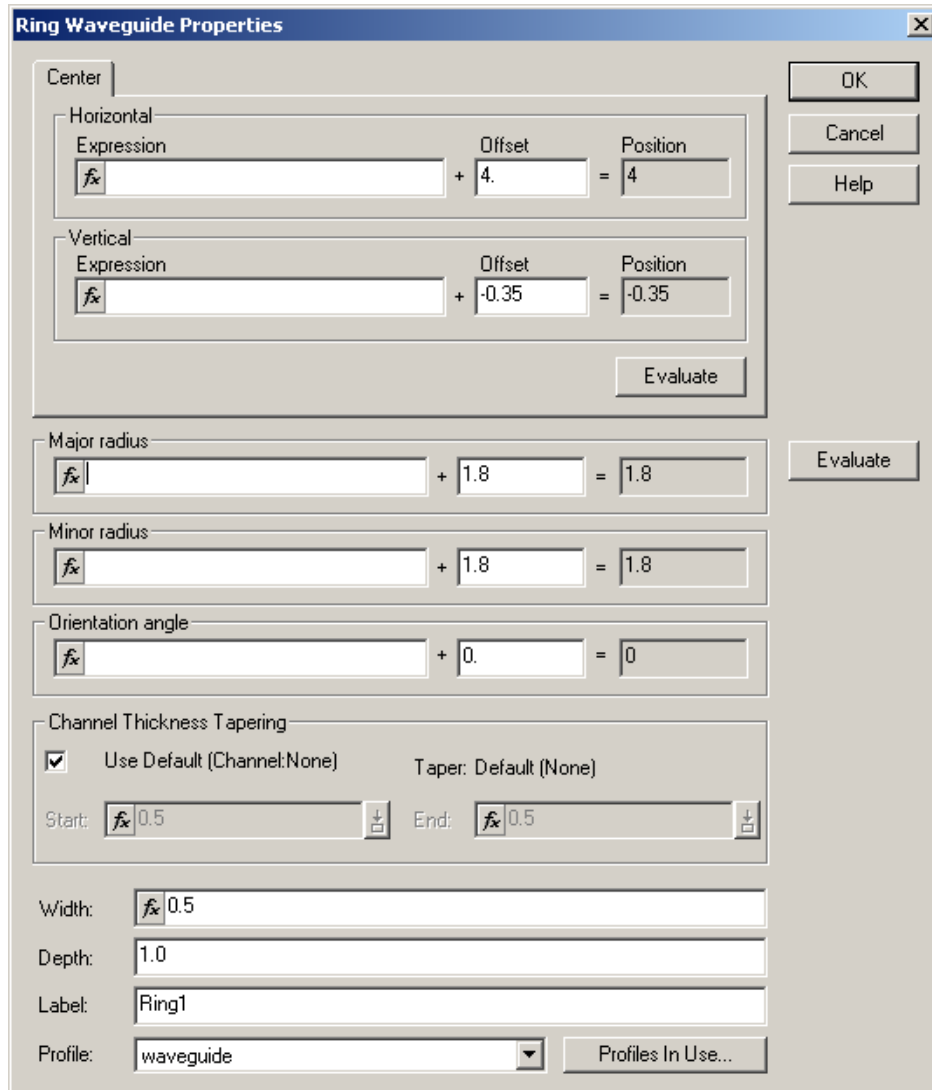
Figure 15 Ring Waveguide



- To adjust the position and the shape of the Ring Waveguide, in the layout window, double-click the Ring Waveguide.
*The **Ring Waveguide Properties** dialog box appears (see [Figure 16](#)).*



Figure 16 Ring Waveguide Properties dialog box

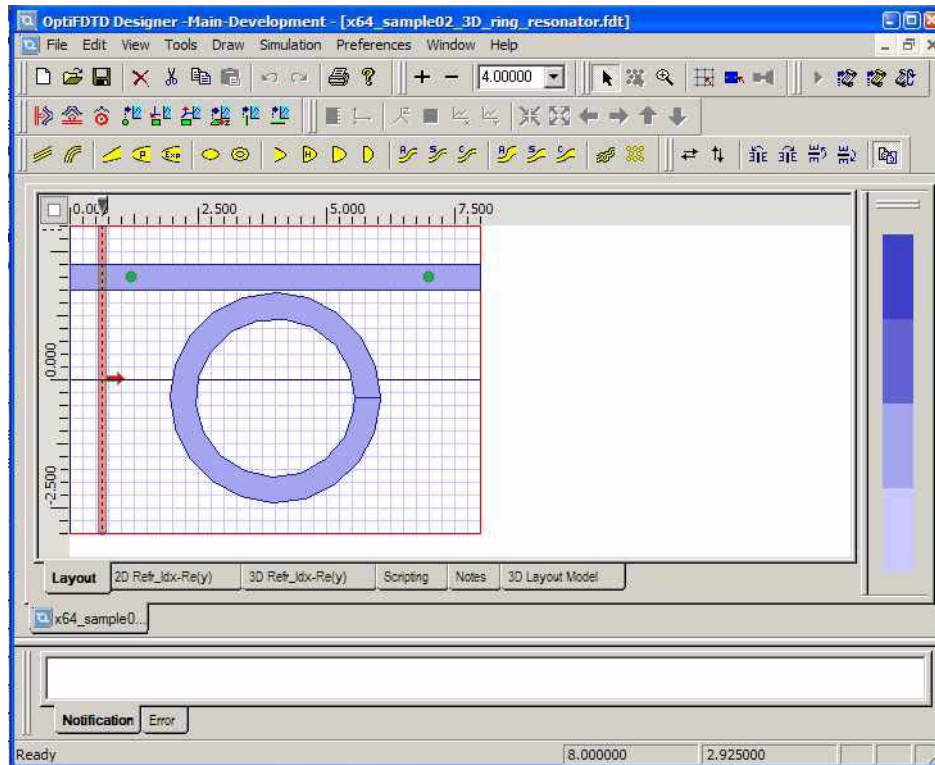


- 4 Type the following values:
 - Horizontal offset (μm): **4.0**
 - Vertical offset (μm): **-0.35**
 - Major radius (μm): **1.8**
 - Minor radius (μm): **1.8**
 - Orientation Angle (degrees): **0**
 - Channel Thickness Tapering: **Use Default (Channel: None)**
 - Width (μm): **0.5**
 - Depth (μm): **1.0**
 - Label: **Ring1**

Note: The Ring Waveguide will be an elliptic ring if the two radii are set to different values.

- 5 From the **Profile** list, select **Waveguide**.
- 6 To save the new values and update the Ring Waveguide, click **OK**.
The modified Ring Waveguide appears in the new position (see [Figure 17](#)).

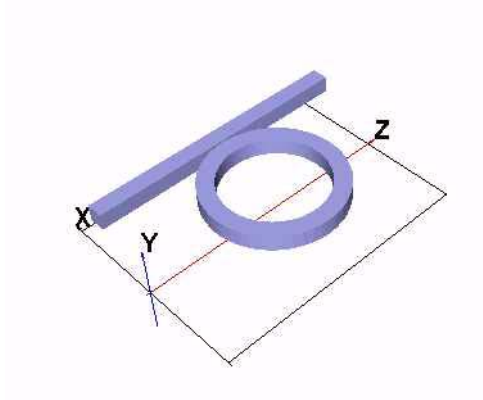
Figure 17 Modified Ring Waveguide



- 7 click **3D Layout Model** button under layout window to observe the design in 3D mode. (see [Figure 18](#))



Figure 18 3D Layout



Note: In 3D Layout window, left clicking the mouse and moving it can change the view angle. Right clicking and holding the mouse and moving it can change the position. Rolling the mouse can zoom in or out in the 3D layout.

Set up the Input Plane

To insert the Input Plane and set the excitation, perform the following procedures.

Inserting the Input Plane

Step Action

- 1 From the **Draw** menu, select **Vertical Input Plane**.

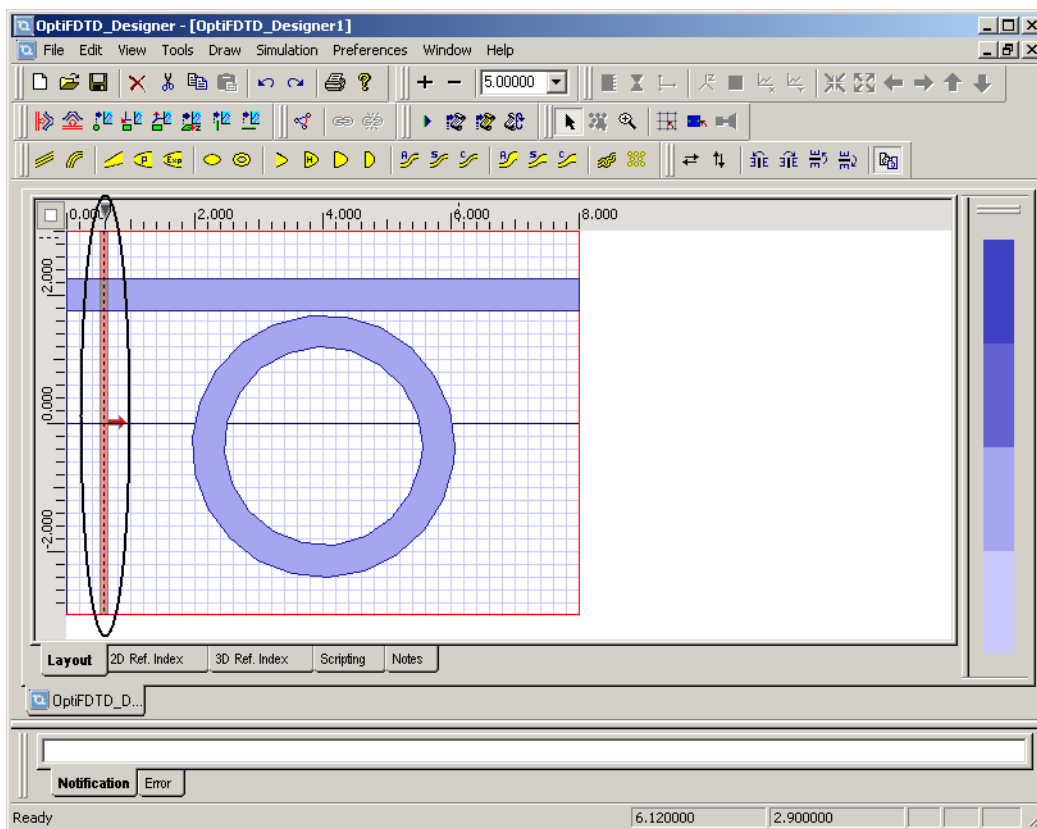
Note:

- The Vertical Input Plane is in the x-y plane for 3D.
- The Horizontal Input Plane is only functional with a 2D simulation.
- Multiple Input Planes are only allowed in a 2D simulation.

- 2 Click in the layout window at the position where you want to insert the Input Plane.

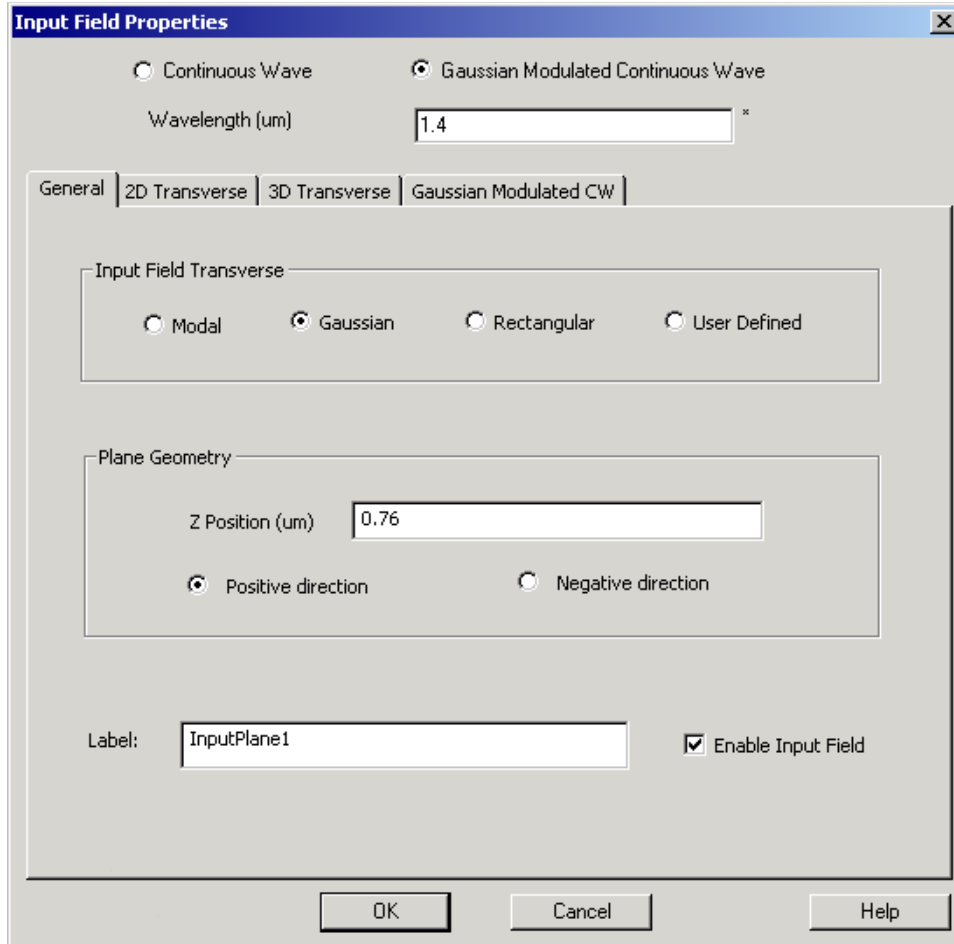
A red line that presents the input plane appears in the layout window (see Figure 19).

Figure 19 Input Plane



- 3 To set up the Input Plane properties, double-click the red line (Input Plane) in the layout window.
*The **Input Field Properties** dialog box appears (see [Figure 20](#)).*

Figure 20 Input Field Properties dialog box



- 4 Set the time domain Input Plane information.
 - a. Select **Gaussian Modulated Continuous Wave**.
*The **Gaussian Modulated CW** tab appears.*
 - b. Wavelength (μm): **1.4**

Note:

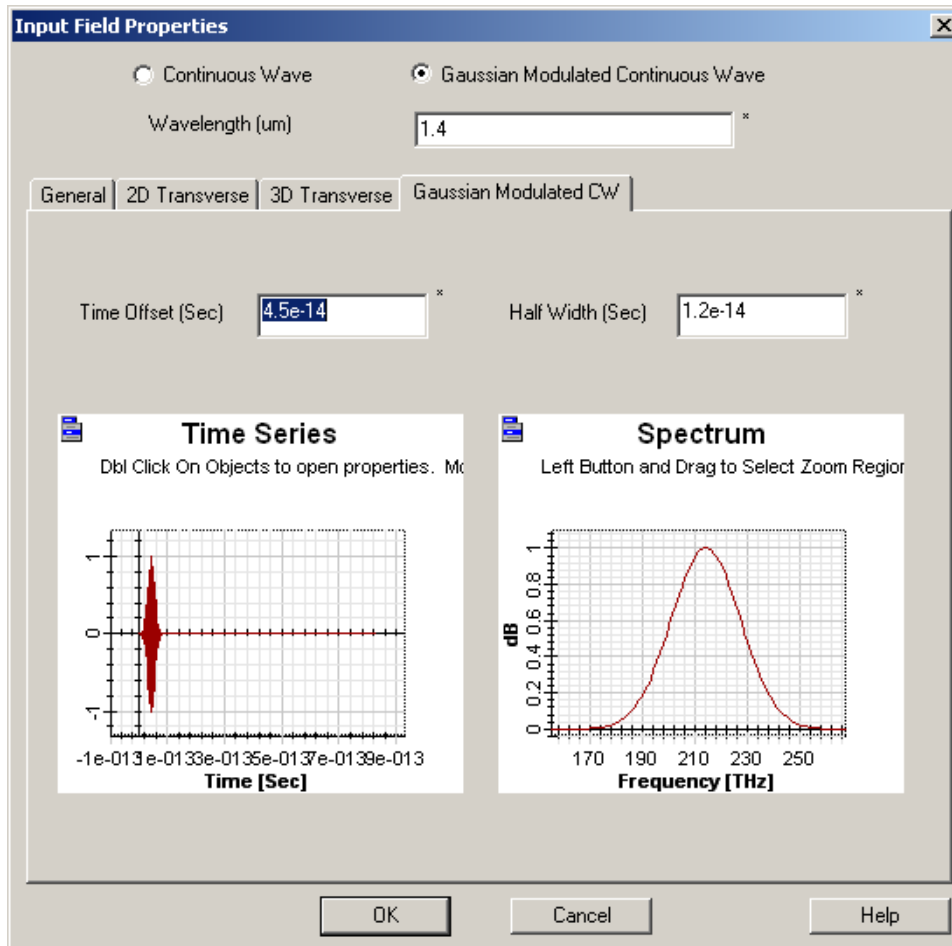
- For Continuous Wave, Wavelength is the single wavelength to be simulated.
- For Gaussian Modulated Continuous Wave, Wavelength is the carrier wavelength (center wavelength) for the pulse.

- 5 Click the **Gaussian Modulated CW** tab.
The time domain pulse graphics appear.



- 6 Type the following values for the time domain input plane (see Figure 21).
 Time offset (sec.): $4.5e-14$
 Half width (sec.): $1.2e-14$

Figure 21 Gaussian Modulated CW tab



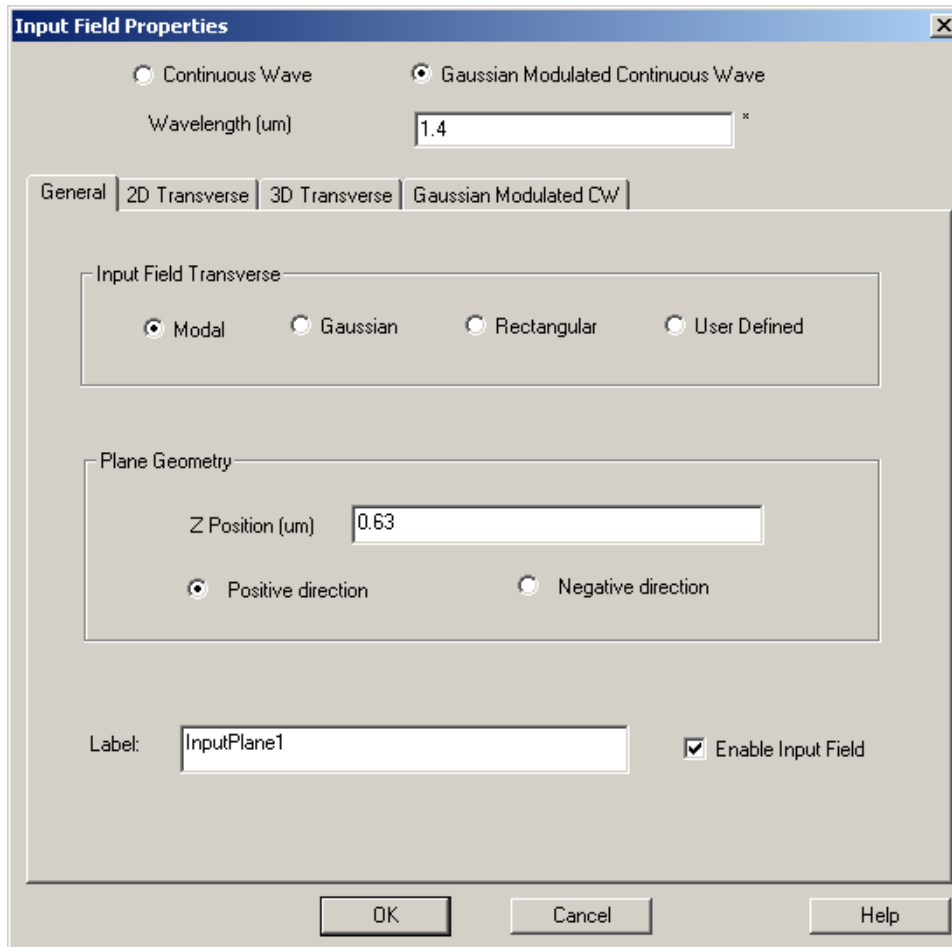
Note:

- Both the time domain wave and frequency domain wave for the Input Plane appear.
- The Frequency domain information is obtained by FFT from the time domain series.
- Right clicking on the graph allows you to select the graph tools.
- Time offset controls the time domain beam center.
- Half width controls the beam size and bandwidth.



- 7 To set up the general information (transverse field distribution) for the Input Plane, click the **General** tab (see [Figure 22](#)).
 - a. Input Field Transverse: **Modal**
 - b. Z Position (μm): **0.63**
 - c. Plane Geometry: **Positive direction**
 - d. Label: **InputPlane1** (default)

Figure 22 General tab

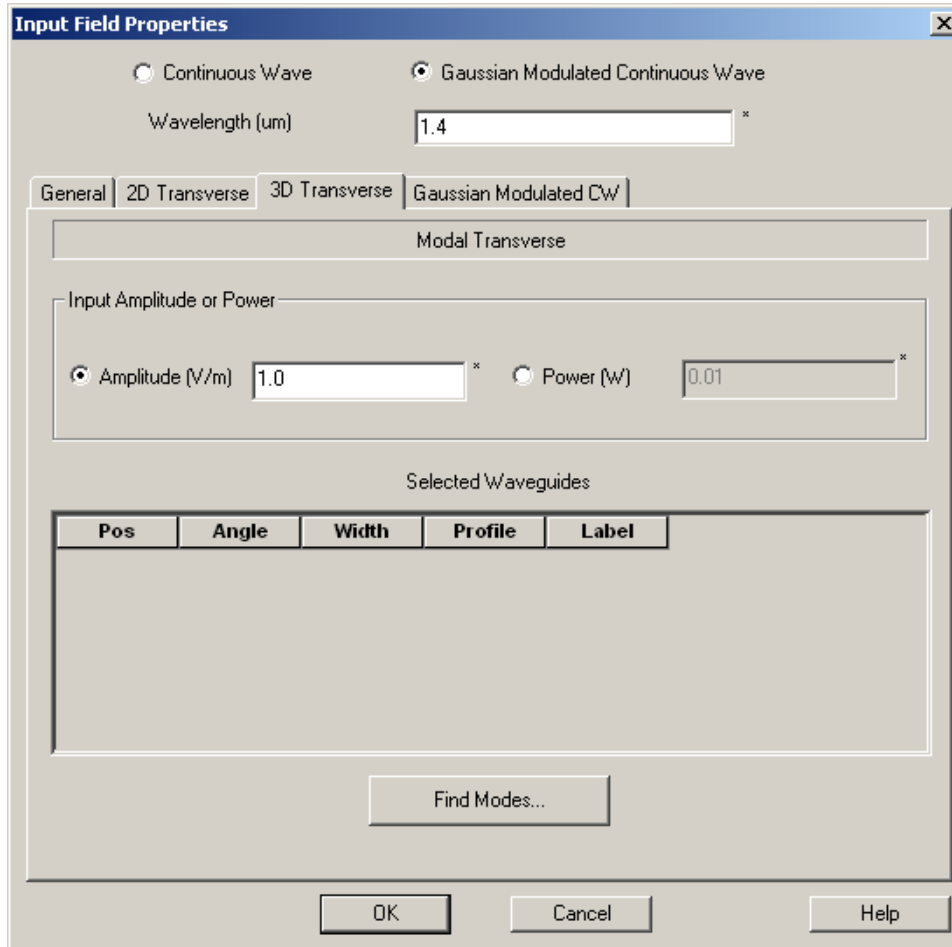


Note: Positive Direction means the that the Input Plane is excited to the positive z-direction. Negative Direction means that the Input Plane is excited to the negative z-direction.



- 8 To solve the 3D transverse mode, click the **3D Transverse** tab (see [Figure 23](#)).

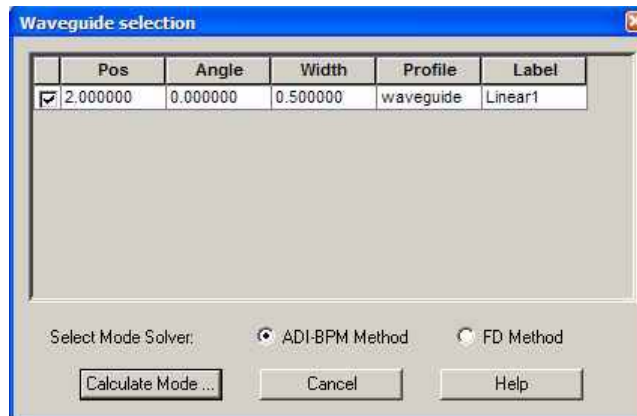
Figure 23 3D Transverse tab



- 9 Type the following Input Amplitude value (V/m): **1.0**
- 10 Click **Find Modes**.
The Waveguide selection window appears (see [Figure 24](#)).

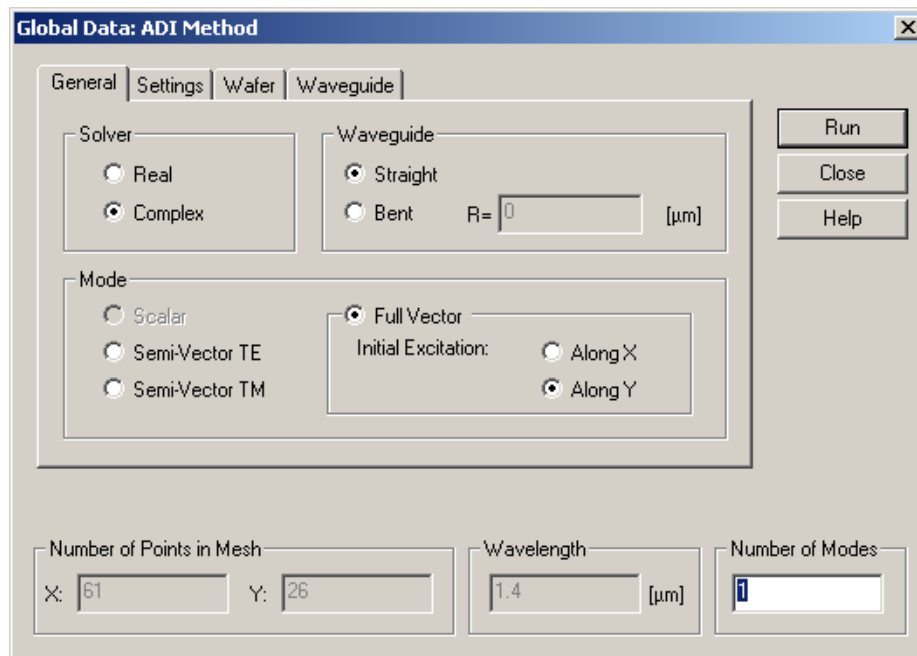


Figure 24 Waveguide selection dialog box



- 11 Select the **Linear Waveguide** check box, select ADI-BPM Method.
- 12 To open the mode solver, click **Calculate Mode**.
The **Globe Data: ADI Method** dialog box appears (see [Figure 25](#)).

Figure 25 Global Data: ADI Method dialog box



- 13 Set the following:
 Solver: **Complex**
 Waveguide: **Straight**
 Mode (initial excitation): **Full Vector, Along Y**

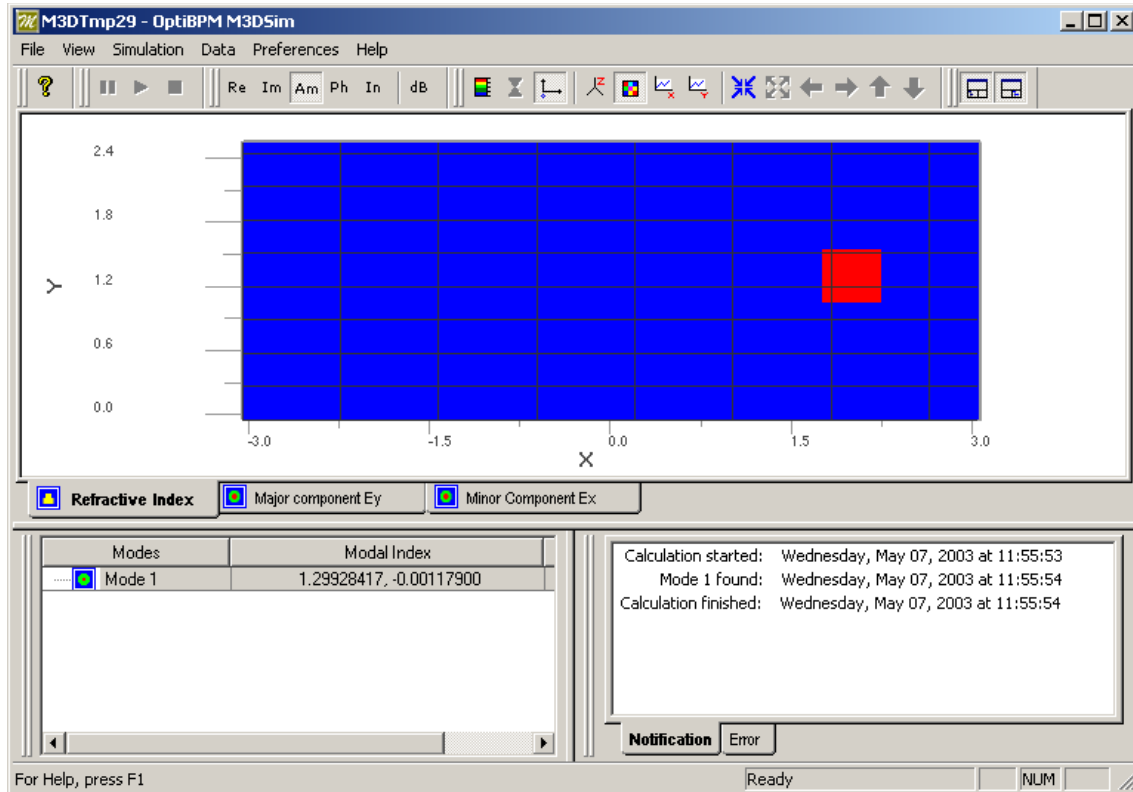


Wavelength (μm): 1.4 (the same as the input wavelength by default, **Read-Only**)

Number of Modes: 1

- 14 Click the **Settings** tab and set **Boundary Condition: TBC**
- 15 To solve the mode, click **Run**.
The 3D Mode Solver opens (see [Figure 26](#)).

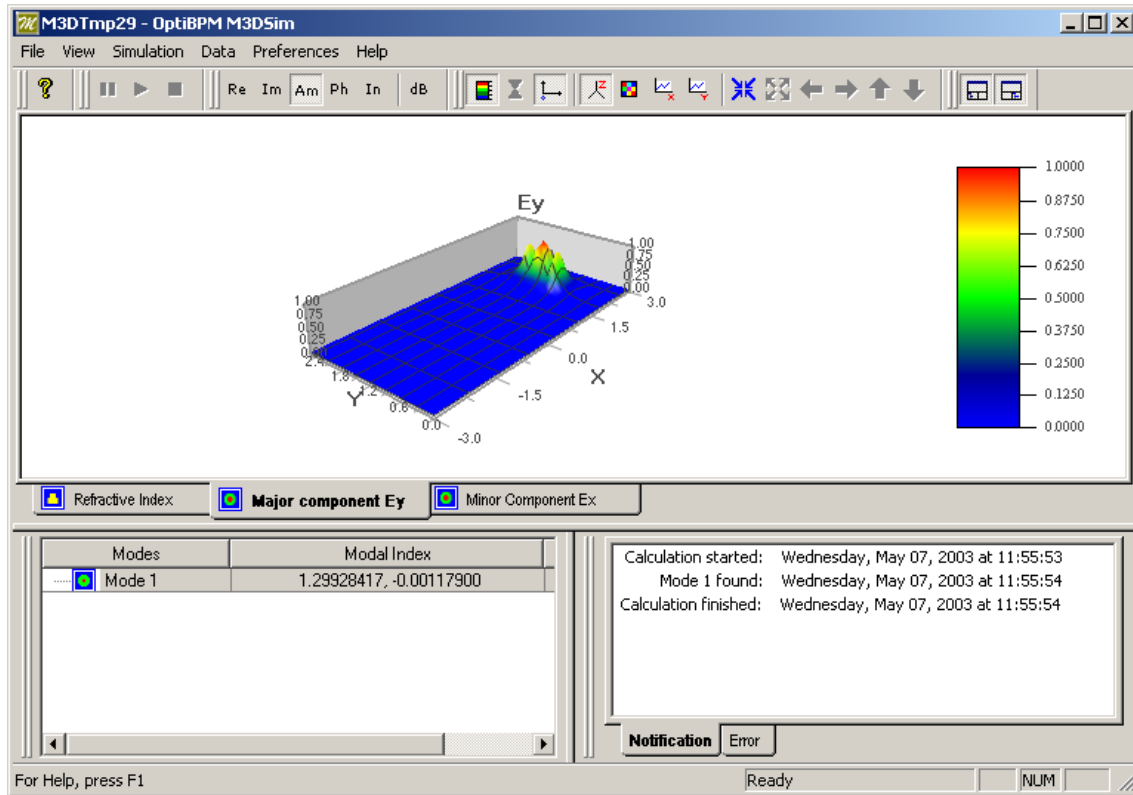
Figure 26 3D Mode Solver



Note:

- The 3D Mode Solver can take a while to start up.
 - It can take several minutes to solve the mode.
 - A message appears to advise you if no mode has been found.
- 16 After solving the mode, click the field (Ex, Ey) tab to view the field pattern (see [Figure 27](#)).

Figure 27 Major component Ey tab



- 17 To return to the **Input Field Properties** dialog box, close the 3D Mode Solver.
- 18 To complete the Input Plane setup, click **OK**.

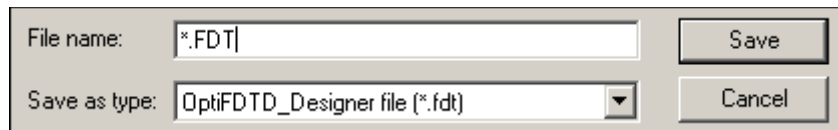


Saving the layout

To save the layout you have created, perform the following procedure.

Note: Do not save your project over the sample file provided.

- | Step | Action |
|-------------|--|
| 1 | From the File menu, select Save As .
<i>The SaveAs dialog box appears.</i> |
| 2 | In the sample folder, enter the name of the file and click Save .
<i>The new sample file is saved in the sample folder.</i> |



File name: *.FDT| Save

Save as type: OptiFDTD_Designer file (*.fdt) Cancel

Note: `.fdt` is the file extension generated by **OptiFDTD_Designer**.



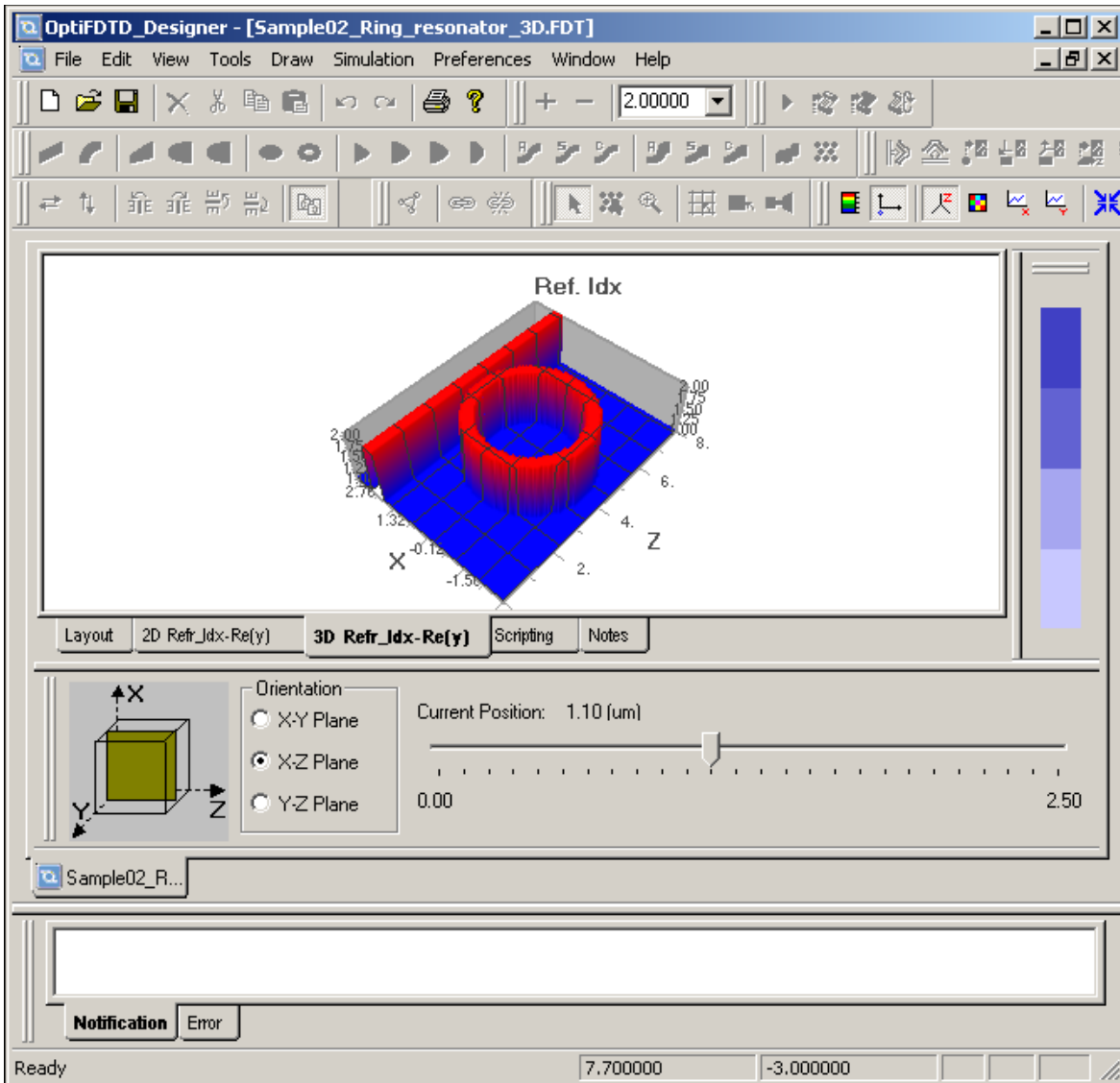
Observe the Refractive Index Distribution

OptiFDTD provides a refractive index viewer to observe the refractive index distribution on any plane in three orientations. To observe the refractive index distribution, perform the following procedure.

Observing the Refractive Index Distribution

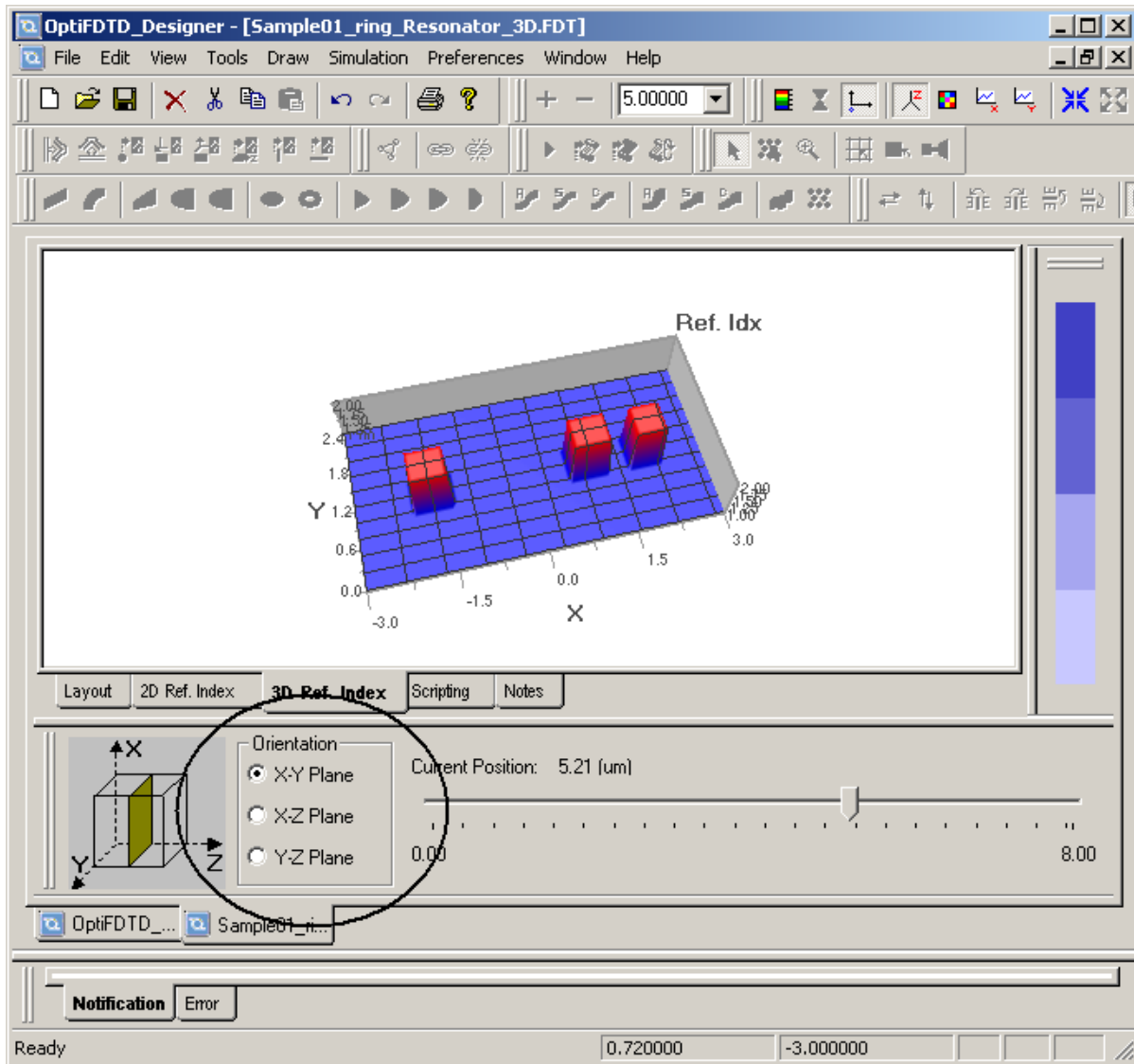
- | Step | Action |
|------|--|
| 1 | Click the 3D Ref. Index tab at the bottom of the layout window.
<i>The 3D Refractive Index window opens (see Figure 28).</i> |

Figure 28 3D Refractive Index tab



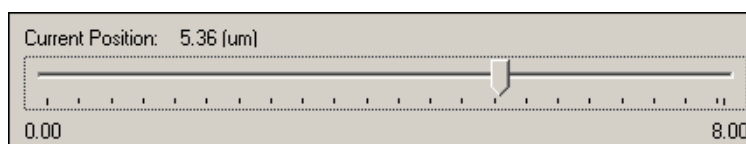
- 2 To view the graphic in height plot format, from the **View** menu, select **3D Graph Items > Height Plot**.
- 3 To view the x-y plane refractive index distribution, under **Orientation**, select **X-Y Plane** (see [Figure 29](#)).

Figure 29 Orientation—X-Y Plane



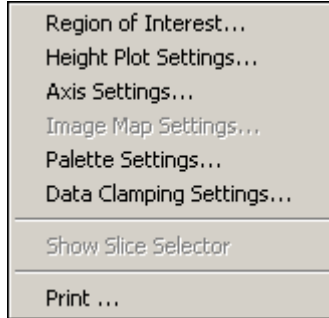
- 4 Move the Slicer slider to the desired position (see [Figure 30](#))

Figure 30 Slicer



- 5 To set more graphic view options, right-click anywhere in the graph (see [Figure 31](#)).

Figure 31 3D Graph Item view options menu



Set up observation points, areas, and lines

Observation point, Line, area, are the post-data detector. Field pattern, transmission function and reflection function (versus wavelength) can be obtained with these detectors

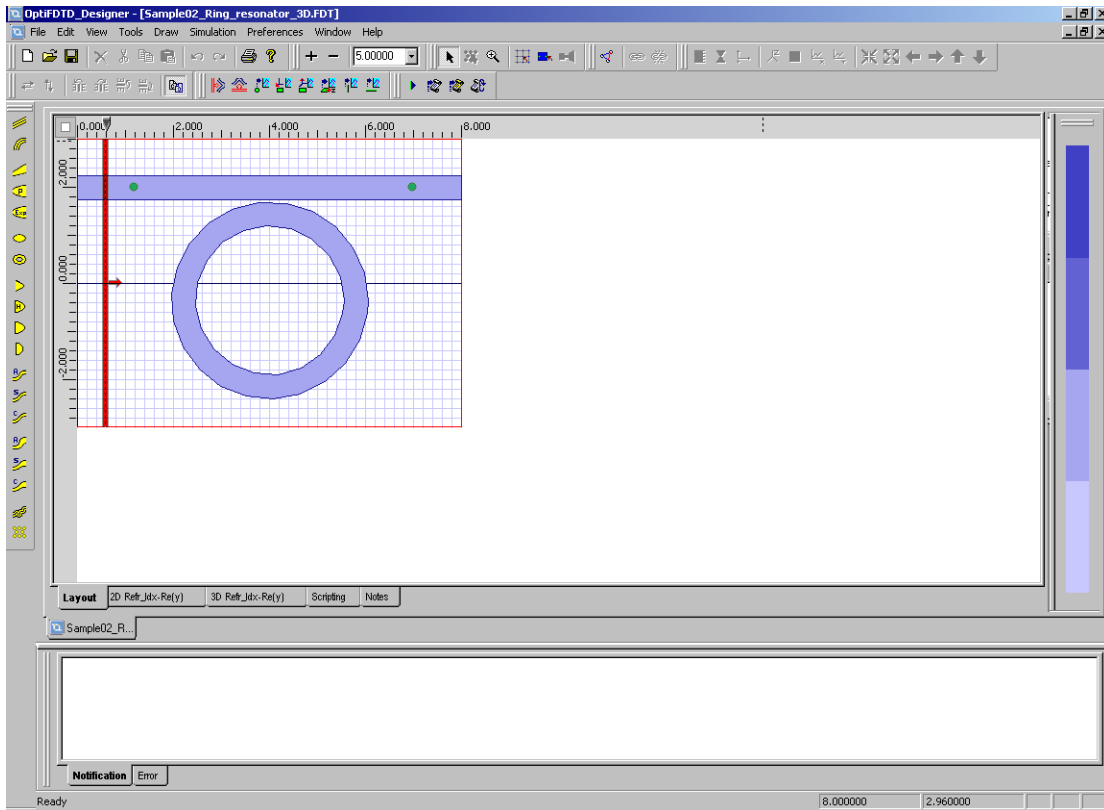
- **Observation Point**—Observe the time domain and frequency domain response. The transmission function can be obtained from the Observation Point analysis if the point detector is put in the waveguide center where the peak value happens.
- **Observation Area**— Observe the field pattern for a give wavelength. compute power transmission ratio, and normalized power versus wavelength. When Observation area is put at the transmitted area, the power transmission function can be obtained. When Observation area is put at reflection area (beyond the input plane), reflection function can be obtained. 32bit simulation will record all the time domain response in the Observation area, user can specify any wavelength to perform the DFT spectrum analysis in analyzer. 64bit simulation performs the spectrum analysis, no time domain response is recorded. Spectrum results for user pre-defined wavelength will be save to analyzer. User can select the wavelength form the list to check the corresponding spectral results in observation area analysis. To Pre-define the wavelength range for 64bit simulation, please click the Spectrum button in the 64bit simulation parameters dialog box.
- **Observation Line**—Only available for a 2D simulation. Observe the frequency domain response, compute power, and normalized power versus wavelength.



Setting up an Observation Point

- | Step | Action |
|------|---|
| 1 | From the Draw menu, select Observation Point . |
| 2 | Click in the layout window where you want to place the Observation Points (see Figure 32). |

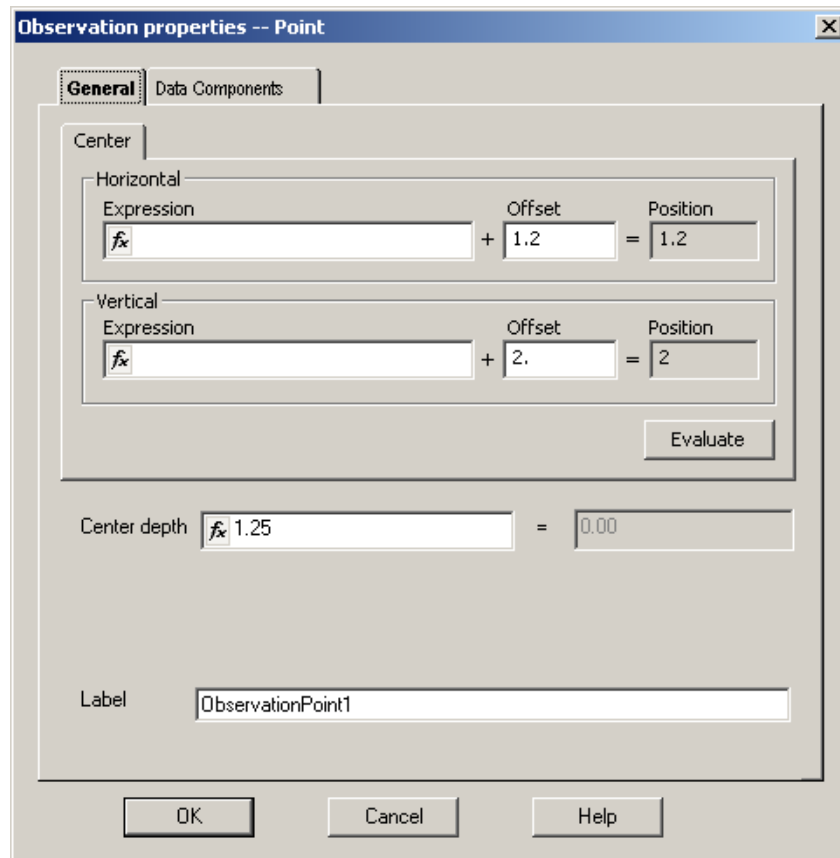
Figure 32 Observation Points



- 3 Double-click the first observation point.
The **Observation properties -- Point** dialog box appears (see [Figure 33](#)).



Figure 33 Observation properties -- Point dialog box

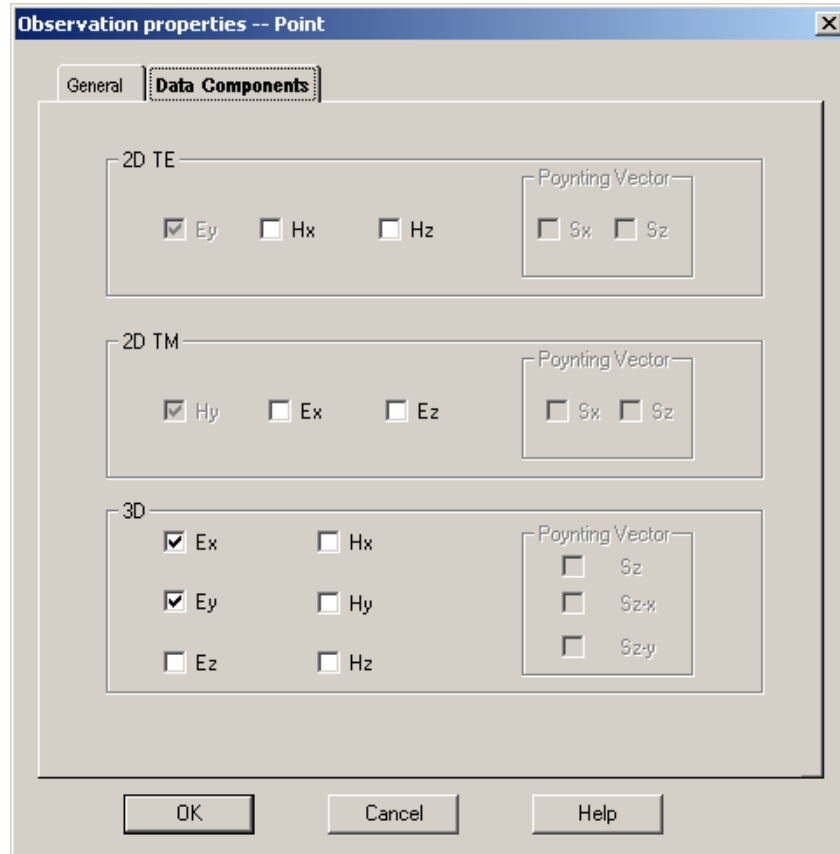


- 4 To adjust the position of the observation point, click the **General** tab and type the following:
 - Horizontal Offset (μm): **1.2**
 - Vertical Offset (μm): **2.0**
 - Center depth (μm): **1.25**
 - Label: **ObservationPoint1** (default)



- 5 To select the field components, click the **Data Components** tab (see [Figure 34](#)).

Figure 34 Data Components tab



- a. Under **3D**, select the **Ex** check box.
 - b. Under **3D**, select the **Ey** check box.
- 6 Repeat steps 3 to 5 for the second observation point, using the following values:
- Horizontal Offset (μm): **7.0**
 - Vertical Offset (μm): **2.0**
 - Center depth (μm): **1.25**
 - Label: **ObservationPoint2** (default)
 - Data Components:
 - i. Under **3D**, select the **Ex** check box.
 - ii. Under **3D**, select the **Ey** check box.



Run the simulation

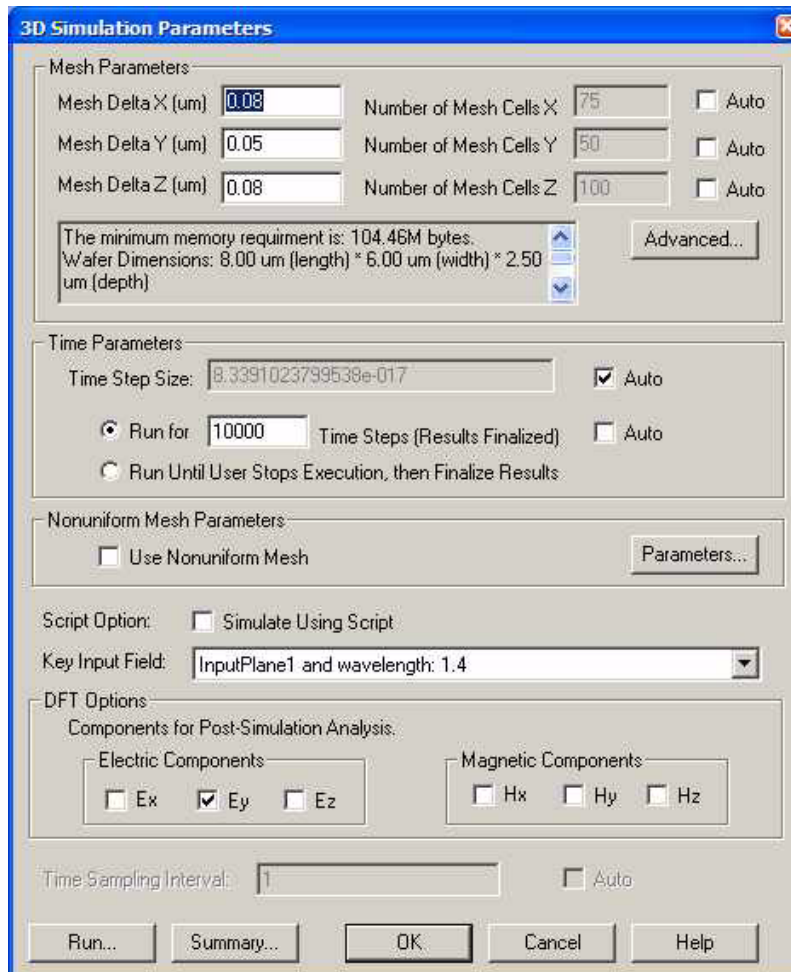
To run the simulation, perform the following procedures.

Note: When you run this simulation for the first time, it is recommended that you run the 2D simulation first. To run the 3D simulation based on this sample file may take up a lot of CPU resources. It is suggested that you use **FDTD_Analyzer** to open the corresponding results file that can be found on the set-up CD.

Setting up the simulation parameters

- | Step | Action |
|------|--|
| 1 | From the Simulation menu, select 3D 32bit Simulation Parameters . The 3D Simulation Parameters dialog box appears (see Figure 35). |

Figure 35 3D Simulation Parameters dialog box



- 2 Type the following values for the mesh size:
Mesh Delta X (μm): 0.08

Mesh Delta Y (μm): 0.05

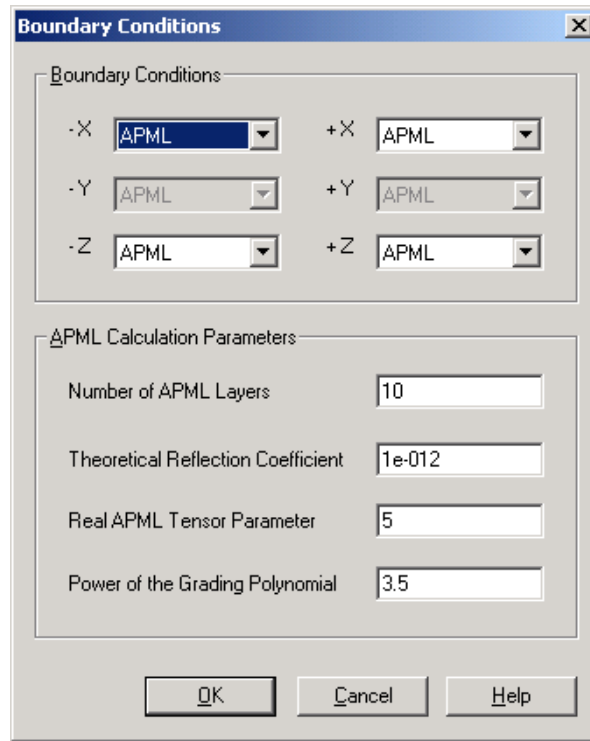
Mesh Delta Z (μm): 0.08

Note: The total mesh number for each orientation will be calculated automatically, once focus is removed from the specific edit region.

- 3 To set up the boundary condition parameters, click **Advanced**.
*The **Boundary Conditions** dialog box appears (see [Figure 36](#)).*



Figure 36 Boundary Conditions dialog box



4 Type the following values for the boundary condition:

- Anisotropic PML layer number: 15
- Theoretical Reflection Coefficient: $1.0e-12$
- Real Anisotropic PML Tensor Parameter: 1.0
- Power of grading Polynomial: 3.5

Note:

- Un-split Perfectly Matched Layer (UPML) was used for the boundary condition in this software. For more information, refer to the ***OptiFDTD Tutorials and Technical Background***.
- The default setting for UPML parameters in OptiFDTD ensures that the outgoing waves are absorbed properly. We recommend that you use the default setting unless you are familiar with UPML boundary conditions.

5 To save the boundary condition setting, click **OK**.

6 Under **Time Parameters**, perform the following:

- a. Click **Calculate** to calculate the time step value.
The new value — $8.3391023799538e-017$ — appears in the Time Step Size field (see [Figure 37](#)).
- b. Type the number of time steps to run: 10000 (see [Figure 37](#)).



Note: The time step value is calculated from the minimum mesh size.

Figure 37 Time Parameters

- 7 From the **Key Input Field** drop-down list, select **Input Plane1 and wavelength 1.4** (see [Figure 38](#)).

Note:

- Key input selection is used to obtain the wavelength for DFT calculation in the simulation.
- For 3D simulations, there is only one input plane.

Figure 38 Key Input Field

- 8 Under DFT Options, select the DFT components that you want to simulate (see [Figure 39](#)).

Figure 39 DFT Options

- 9 Select **Ey** check box.

Note:

- The discretized Fourier transform (DFT) will run for the selected field components for the key input wavelength in the simulator.
- The DFT results will be saved for performing post simulation analyses, such as Far Field Pattern, Mode Overlap Integral calculation, Input Overlap Integral calculation, and observation of the frequency domain field pattern.



- 10 To start 3D 32bit simulation, click **Run** in the simulation dialog box.

Note: 64bit simulation on multiple core system will be much faster than 32bit simulation. To perform the 64bit simulation, please read the chapter “know the difference between 32bit simulation and 64bit simulation” or tutorial lesson 18



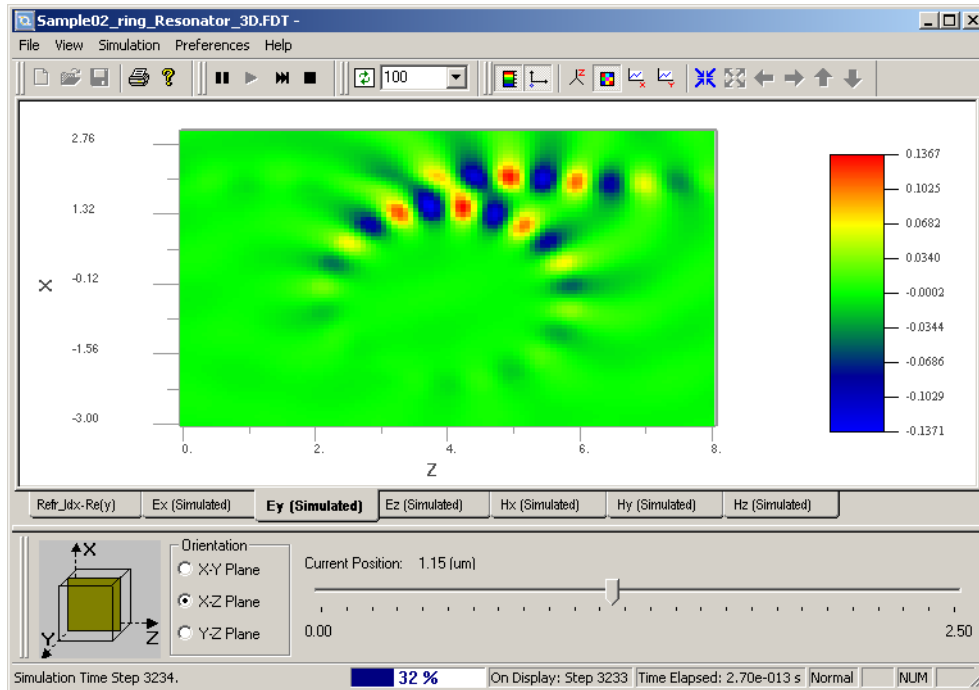
Running the 32bit simulation

OptiFDTD_Simulator is a separate window that displays the simulation as it runs.

Step Action

- 1 To observe the simulated field components in one slice, perform one of the following (see [Figure 40](#)):

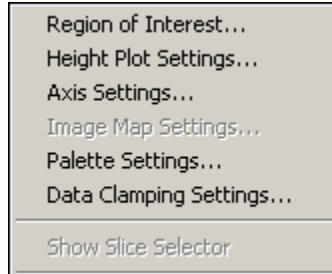
Figure 40 3D Simulation results



- From the **View** menu, select **3D Graph Items**, and then select the type of view that you want (for example, Height Plot, Image Map, or Plane View).
- To open the a context menu listing the 3D Graph Items, right-click anywhere in the graph (see [Figure 41](#)).

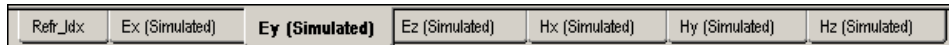


Figure 41 3D Graph Items list



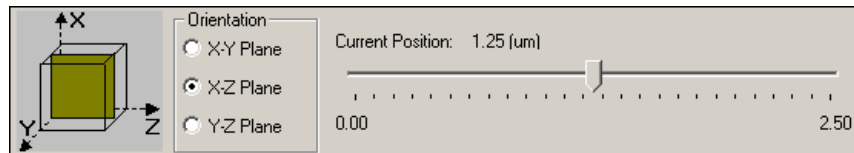
- Select the field components and refractive index that you want to view by clicking the corresponding tab (see [Figure 42](#)).

Figure 42 Component tabs



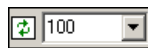
- To specify the slice orientation and the position, move the Slice Chooser slider to the desired value (see [Figure 43](#))

Figure 43 Slice Chooser



- To specify the step interval number for updating the simulated field data, select a new value from the **View Update** list (see [Figure 44](#)).

Figure 44 View Update list



- 2 To pause, resume, stop and finalize the simulation, from the **Simulation** menu, select the action you want to perform

OR

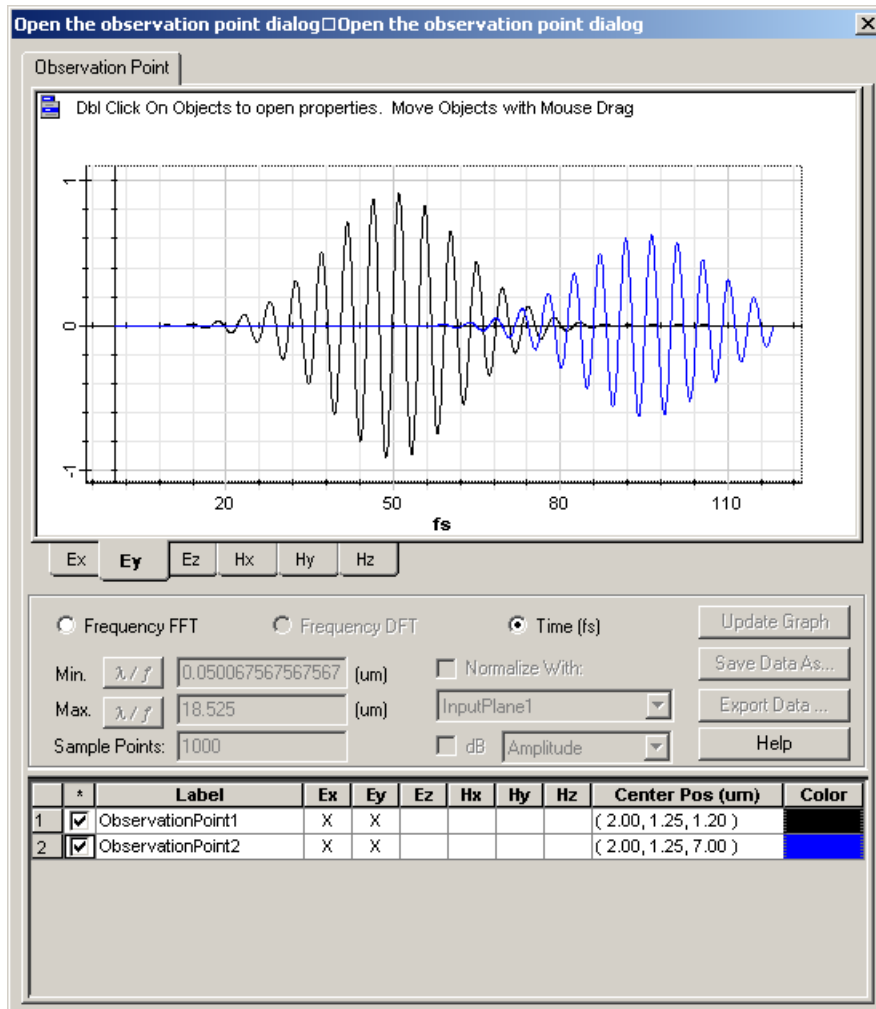
Click the corresponding button on the **Simulation** toolbar (see [Figure 45](#)).

Figure 45 Simulation toolbar



- 3 To view the observation point in the simulator, from the **View** menu, select **Observation Points**.
*The **Observation Area Analysis** dialog box appears (see [Figure 46](#)).*

Figure 46 Observation Area Analysis dialog box



- 4 To observe the time domain response on a single point, select the following (refer to [Figure 46](#)):
 - field components
 - observation point
 - time



- 5 To observe the frequency domain response on a single point, select the following (refer to [Figure 46](#)):
 - field components
 - observation point
 - Frequency FFT
- 6 To change the x-axis to frequency or wavelength, click **Frequency/Wavelength**.



Analyze the simulation results

In this lesson, you have created a design, run a simulation, and loaded the corresponding simulation results file into OptiFDTD_Analyzer. The following analysis is based on this sample.

OptiFDTD_Analyzer displays the simulation results and allows you to perform a post-simulation analysis. To analyze the simulation results, perform the following procedures.

Note: If you do not use the simulation results file sample you created, the OptiFDTD software CD has the results file available. Copy it and open the file using the OptiFDTD_Analyzer.

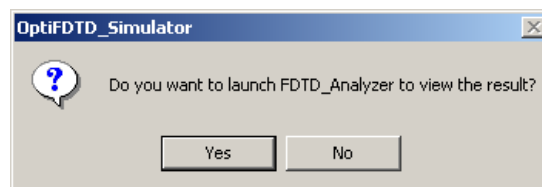
Opening OptiFDTD_Analyzer

OptiFDTD_Analyzer can be opened in one of two ways.

From OptiFDTD_Simulator

When the simulation ends, a message appears and prompts you to open OptiFDTD_Analyzer (see [Figure 23](#)).

Figure 47 Message box



Action

- To open OptiFDTD_Analyzer and view the simulated results, click **Yes**.

Note: When the simulation ends in OptiFDTD_Simulator, the results are saved automatically as a file with same name, but with a different file extension (* .**fd**a).

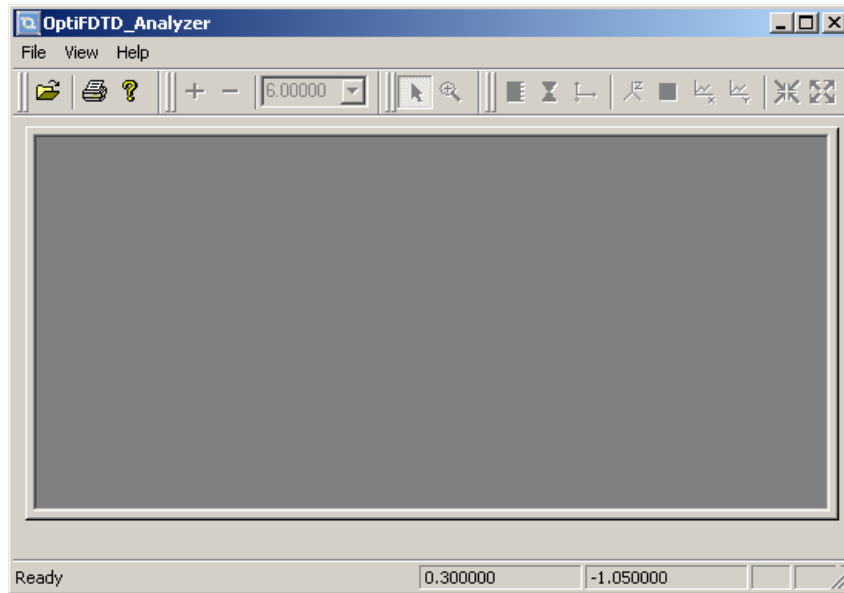
From the Start menu

Step Action

- From the **Start** menu, select **Programs > Optiwave Software > OptiFDTD > Results Analyzer**.
OptiFDTD_Analyzer opens (see [Figure 48](#)).

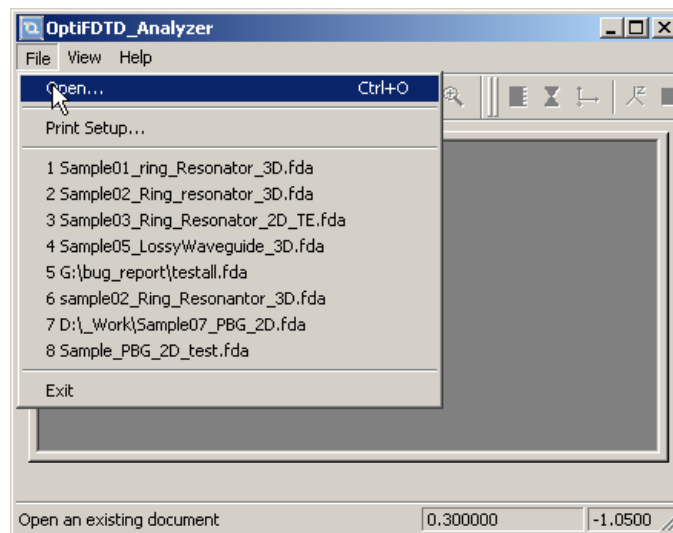


Figure 48 OptiFDTD_Analyzer



- 2 To open an existing simulation results file (*.fda), from the **File** menu, select **Open** (see Figure 49).

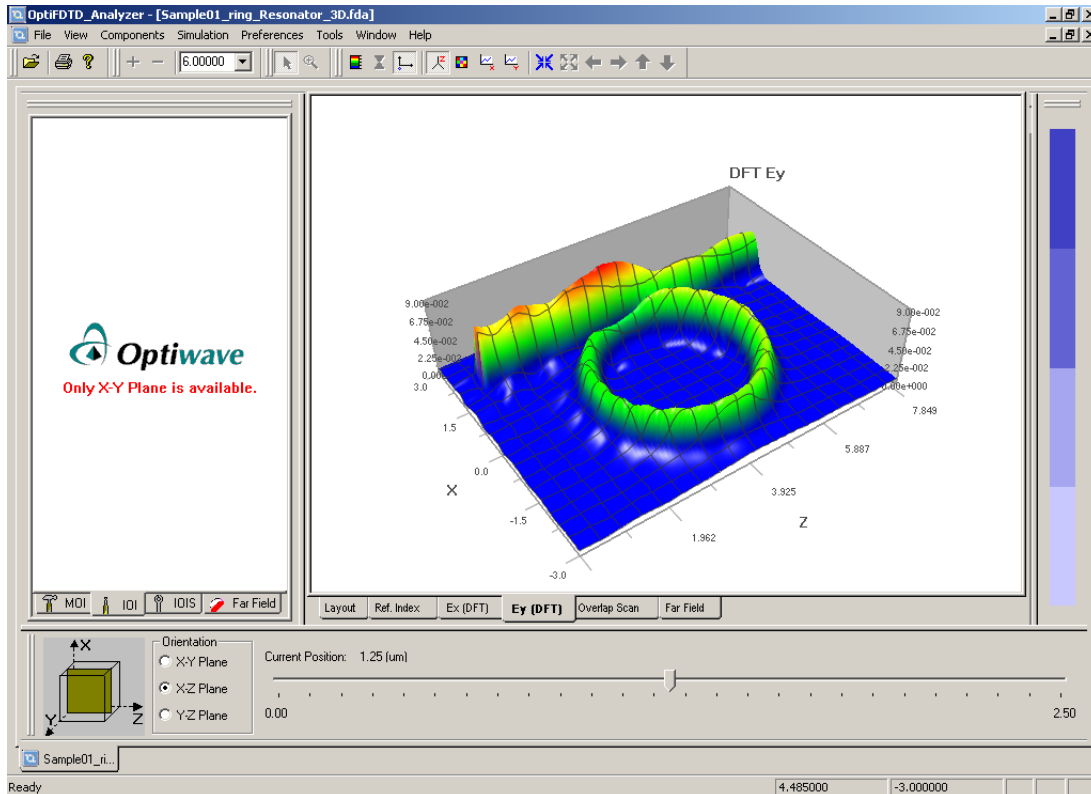
Figure 49 File menu



Analyzing the results

- | Step | Action |
|------|---|
| 1 | View the field distribution (after the DFT results) for the center (carrier) wavelength (see Figure 50). |

Figure 50 Field distribution



Note:

- You can specify the orientation and the observation plane position.
- You can only view the simulation results and the Poynting Vector for the components that you selected for DFT calculation in the **3D Simulation Parameters** dialog box.

Note: Proceed to the next step if the required components have been selected in the layout for the Power calculations.

- | | |
|---|---|
| 2 | Calculate and observe the Power value and the Normalized Power value (to the input plane) for the current slice position. |
|---|---|

Note:

- The power calculation is available only if related components are selected in the **3D Simulation Parameters** dialog box.



- The power types for each slice are power in two-direction polarization and the total power.

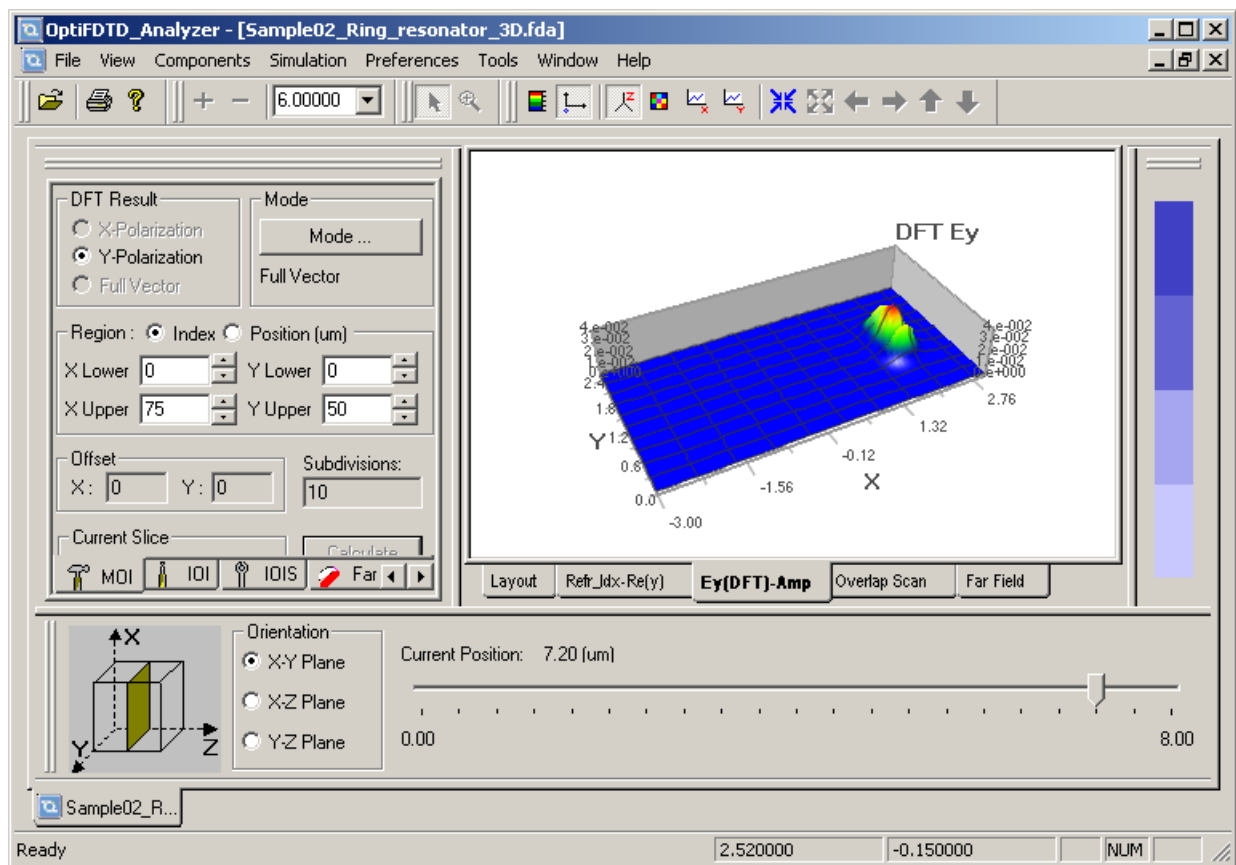
Calculating the Mode Overlap Integral (MOI)

You can perform the Mode Overlap Integral (MOI) calculation on the X-Y plane only.

Step Action

- 1 Under **Orientation** on the Slice Chooser, select **X-Y Plane**.
- 2 Move the slider position to **7.2 μm** (see [Figure 51](#)).

Figure 51 Slice Chooser



- 3 In the Analysis Tools window, click the **MOI** tab.
The **MOI** tab appears (see [Figure 52](#)).



Figure 52 MOI tab

The screenshot shows the MOI tab interface with the following settings:

- DFT Result:** Y-Polarization (selected)
- Mode:** Full Vector
- Region:** Index (selected)
- X Lower:** 0
- Y Lower:** 0
- X Upper:** 75
- Y Upper:** 50
- Offset:** X: 0, Y: 0
- Subdivisions:** 10
- Current Slice:** Orientation: X-Y, Z - Position: 90 (7.20 um)
- Buttons:** Calculate, Help
- Statistics:** Result: 77.7126 [%], -1.0951 [dB]
- Toolbar:** MOI, IOI, IOIS, Far

- 4 Type or select the following information:

DFT Result: **Y-Polarization**

Region: **Index**

X Lower: 0

X Upper: 75

Y Lower: 0

Y Upper: 50

Offset: 0

Note: The default parameters are for the entire slice region.

- 5 To find the mode on the current slice, click **Mode**.

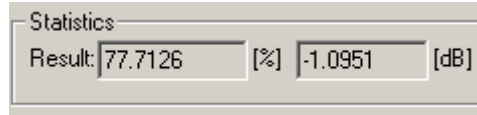
*When the mode solver finds a mode, the **Calculate** button becomes available.*



Note: Ensure that the mode solving in this step has the same conditions are as the ones you used when you solved the mode for the **Input Plane**. Refer to Steps 13, 14, and 15 on page 114.

- 6 To perform the MOI calculation, click **Calculate**.
The results appear under **Statistics** in the **Result** field (see Figure 53).

Figure 53 MOI calculation results



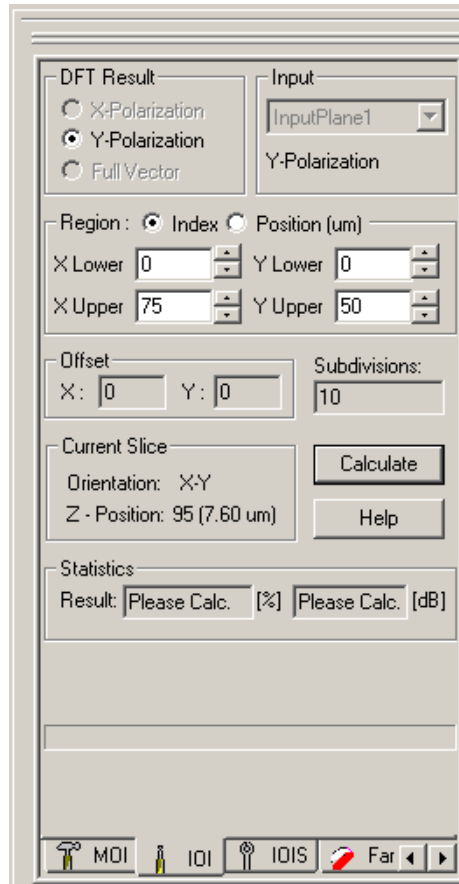
Calculating the Input Overlap Integral (IOI)

- Compare the simulated output and the input

Step Action

- 1 Under **Orientation** on the Slice Chooser, select **X-Y Plane**.
- 2 Move the slider position to **7.6 μm**
- 3 In the Analysis Tools window, click the **IOI** tab.
The **IOI** tab appears (see Figure 54).

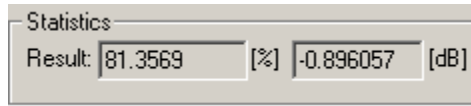
Figure 54 IOI tab



Note: Use the default settings for the IOI calculation parameters.

- 4 To perform the IOI calculation, click **Calculate**.
The results appear in Statistics in the Results field (see [Figure 55](#)).

Figure 55 IOI calculation results



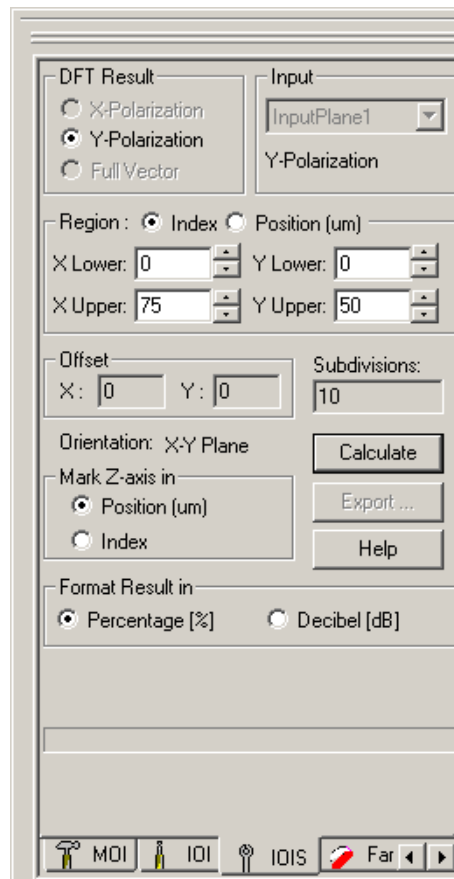
Calculating the Input Overlap Integral Scanner (IOIS)

- Compare the input field and the output field at each X-Y slice.
- Power transmission ratio to the input wave at z-direction

Step Action

- 1 Under **Orientation** in the Slice Chooser, select **X-Y Plane**.
- 2 In the Analysis Tools window, click the **IOIS** tab.
The **IOIS** tab appears (see [Figure 56](#)).

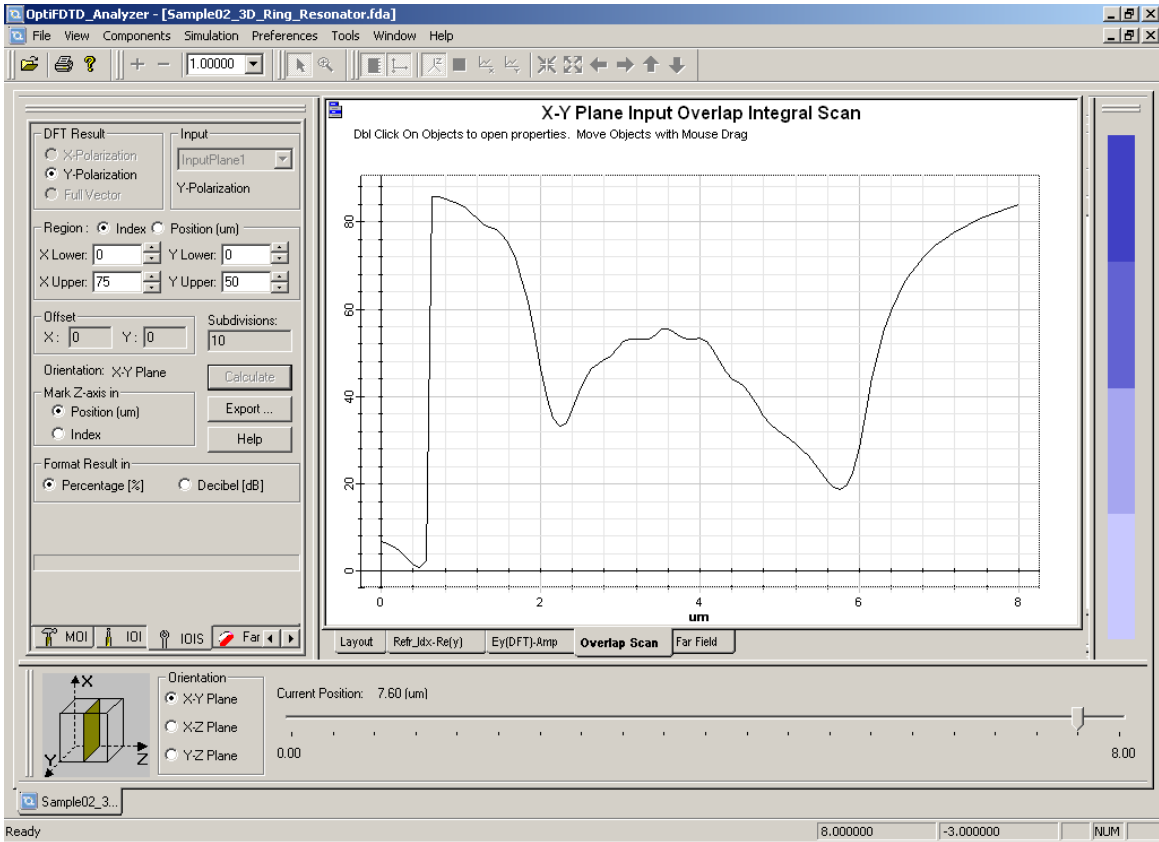
Figure 56 IOIS tab



Note: Use the default settings for the IOIS calculation parameters.

- 3 To perform the IOIS calculation, click **Calculate**.
The results graph appears in the **Overlap Scan** window (see [Figure 57](#)).

Figure 57 IOIS calculation results



Note:

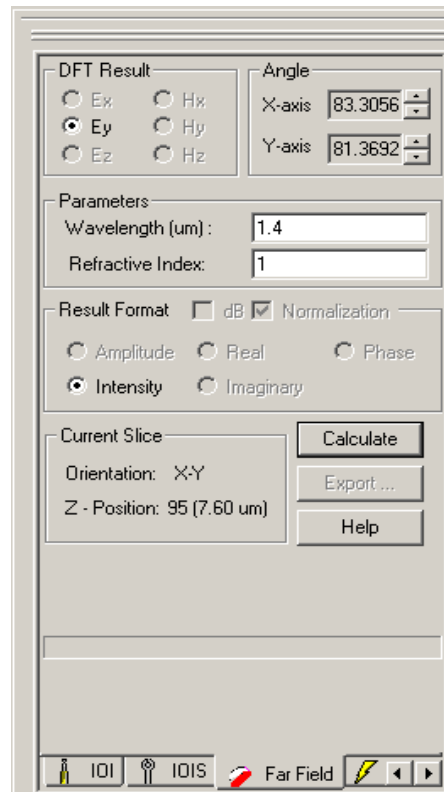
- The IOIS calculation goes through the entire Z-direction.



Calculating the Far Field Transform

- | Step | Action |
|------|---|
| 1 | Under Orientation on the Slice Chooser, select X-Y Plane . |
| 2 | Move the slider position to 7.6 μm |
| 3 | In the Analysis Tools window, click the Far Field tab.
<i>The Far Field tab appears (see Figure 58).</i> |

Figure 58 Far Field tab



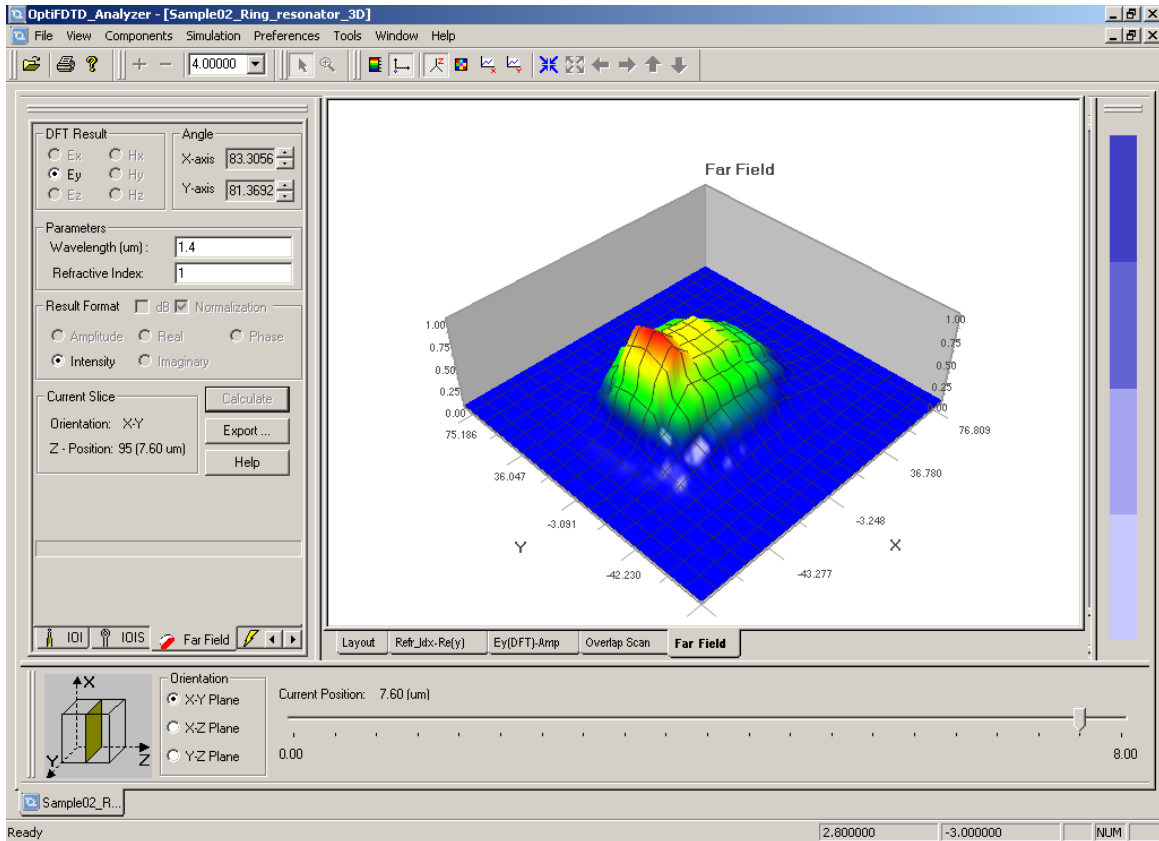
Note: You can select DFT components at any slice to perform the far field calculation.

- 4 Select the following information:
- DFT Result: **Ey**
 - X-axis angle: **83.3056**
 - Y-axis angle: **81.3692**
 - Wavelength: **1.4 μm**
 - Refractive Index: **1**



- 5 To perform the far field transform, click **Calculate**.
- 6 To view the far field distribution, click the **Far Field** tab at the bottom of the layout window (see [Figure 59](#)).

Figure 59 Far field calculation result



- 7 To save the Far Field Transform results, in the Analysis Tools window, click **Export**.

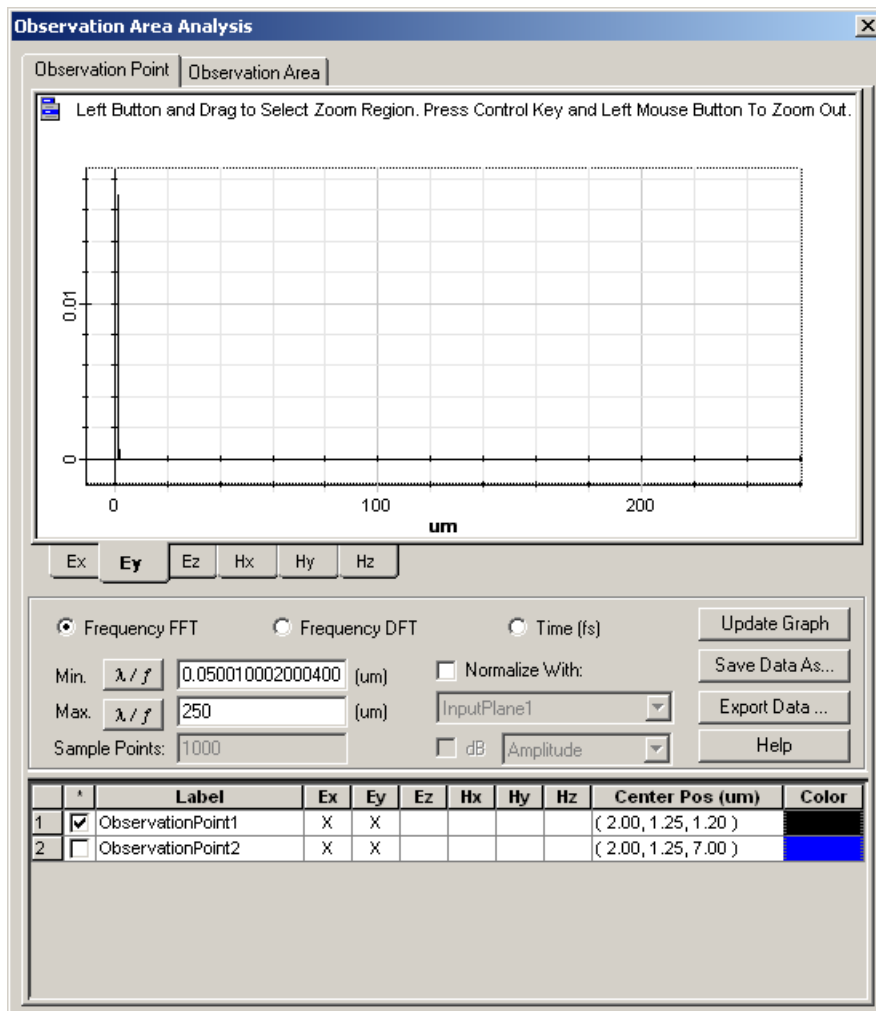


Performing the Observation Object Analysis

Step Action

- 1 From the **Tools** menu, select **Observation Area Analysis**.
The **Observation Area Analysis** dialog box appears (see [Figure 60](#)).

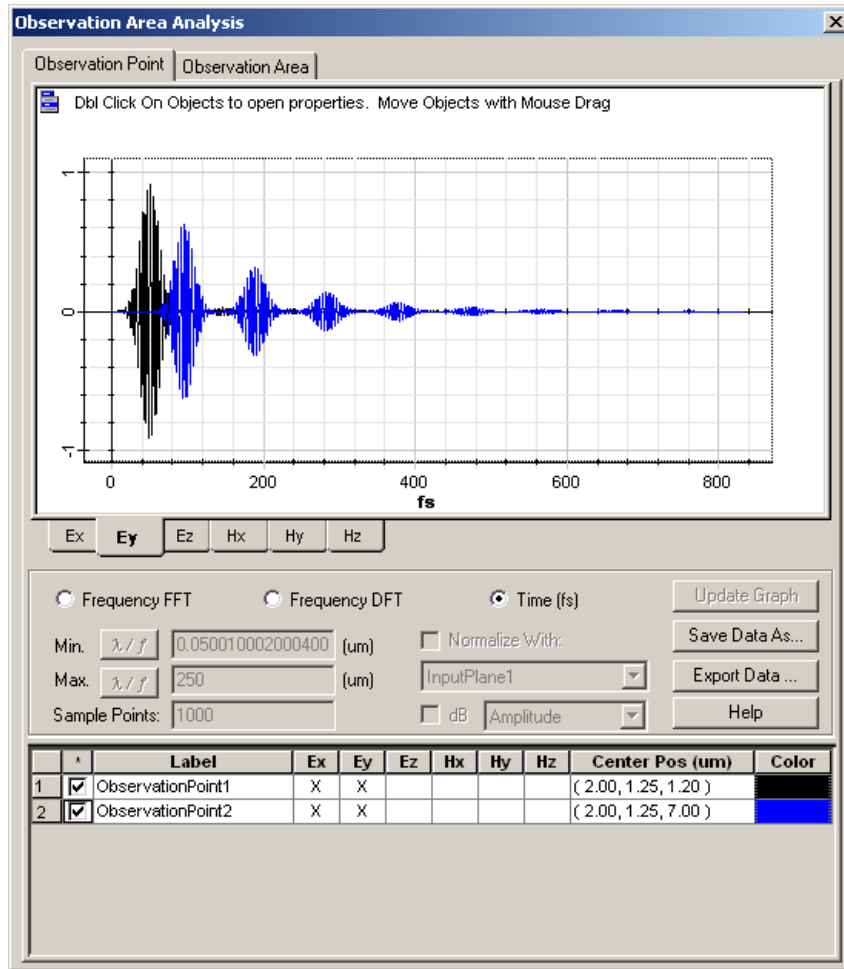
Figure 60 Observation Area Analysis dialog box



- 2 Click the **Observation Point** tab to perform the observation point analysis.
 - a. To view the Time Domain Response:
 - i. Click **Times (fs)**.
 - ii. Under **Label**, select the check box for the observation point or points that you want to view.
 - iii. Select the tab under the graph for the field component that you want to view.



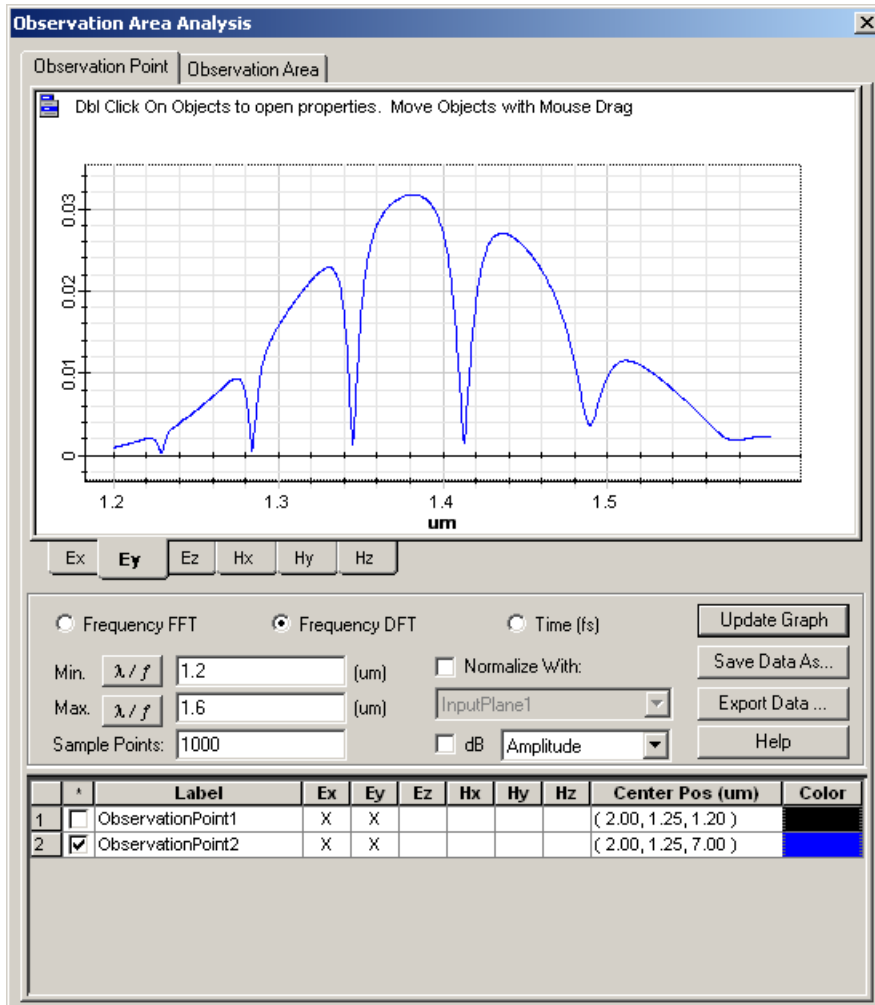
Figure 61 Observation Point analysis—Time Domain Response



- b. To view the Frequency Domain Response:
 - i. Click **Frequency DFT**.
 - ii. Under **Label**, select **ObservationPoint2**.
 - iii. Select the field component **Ey**.
 - iv. Set the wavelength/frequency range and the sampling point number.
 Minimum wavelength: **1.2 μm**
 Maximum wavelength: **1.6 μm**
 Sampling point: **1000**
 - v. Click **Update Graph** to view the graph (see Figure 62).
 - vi. To set the X-axis units, click **Wavelength/Frequency**.



Figure 62 Observation Point analysis—Frequency Domain Response



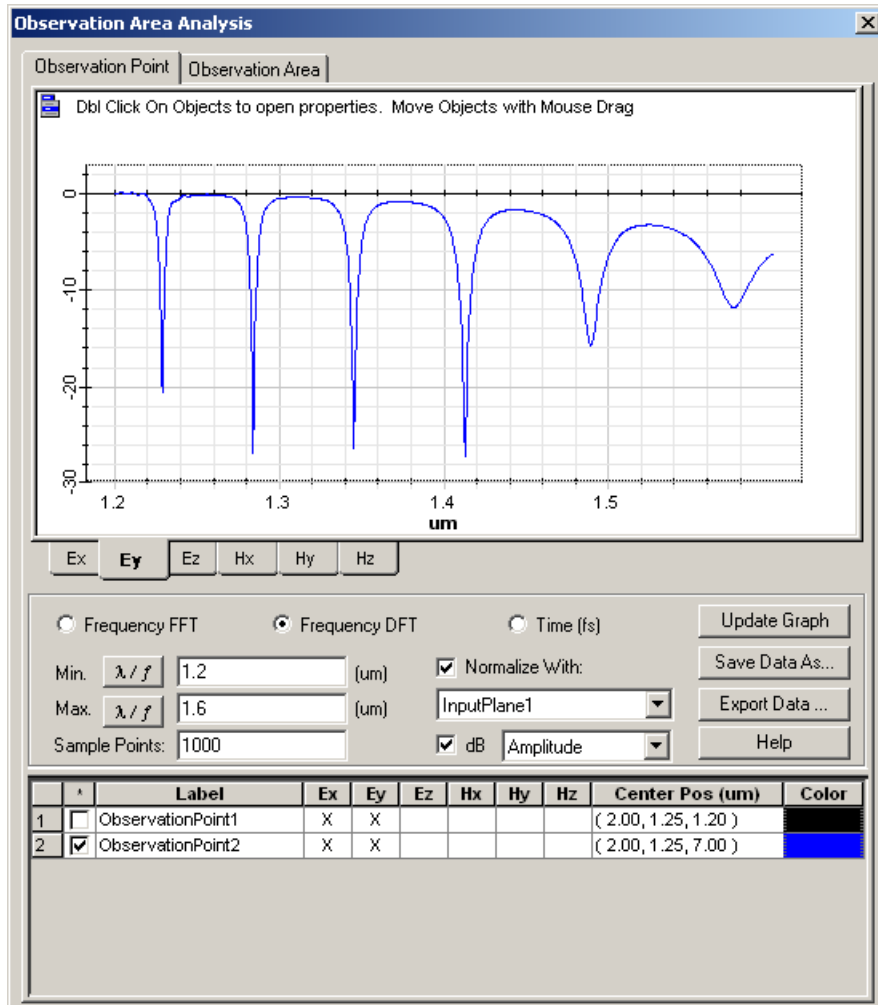
Note: You can specify the type of curve—amplitude, phase, real part, Imaginary part, or decibel.

- c. To calculate the transmission/normalized response:
 - i. Click **Frequency DFT**.
 - ii. Under **Label**, select **ObservationPoint2**.
 - iii. Select the field component **Ey**.
 - iv. Set the wavelength/frequency range and the sampling point number.
 Minimum wavelength: **1.2 μm**
 Maximum wavelength: **1.6 μm**



- Sampling point: 1000
- v. Select **Normalized with**.
- vi. In the Input plane list, select **Input Plane1**.
- vii. Select **dB** to view the transmission function.
- viii. Click **Update Graph** to view the graph (see Figure 62).

Figure 63 Observation Point Analysis—Normalized response



Note: The following two steps can only be executed if the **Observation Area** and the **Line** have been designed in the **Layout** window.

- 3 Click the **Observation Area** tab to perform the observation area analysis and follow the substeps for **Observation Point**.
- 4 Click the **Observation Line** tab to perform the observation line analysis (**2D simulation only**) and follow the substeps for **Observation Point**.



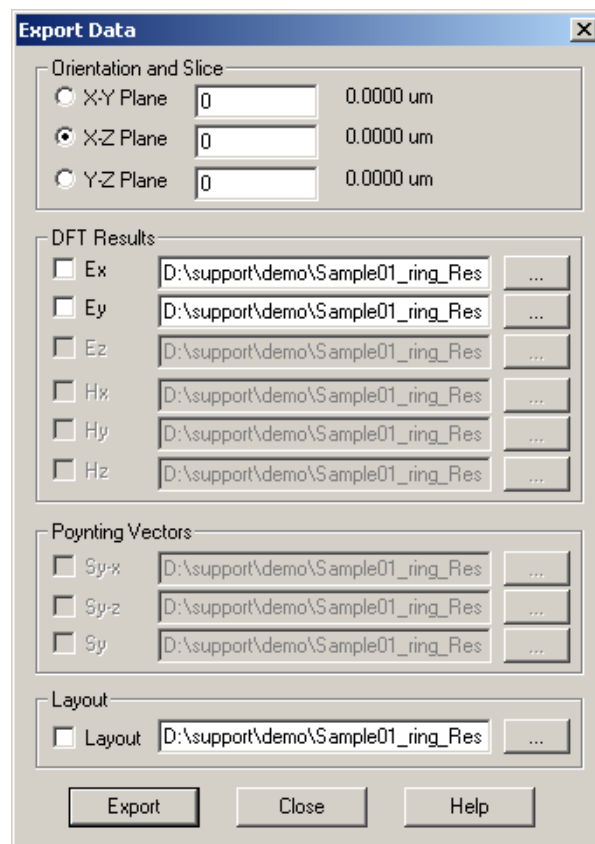
Export results

You can export the DFT results, refractive index, Poynting Vector, and layout in the desired slice from OptiFDTD_Analyzer to a location that you choose.

Exporting results

- | Step | Action |
|------|---|
| 1 | From the File menu, select Export .
<i>The Export Data dialog box appears (see Figure 64).</i> |

Figure 64 Export results



- | | |
|---|---|
| 2 | Select the results that you want to export, and click Export . |
|---|---|



LESSON 1—GETTING STARTED



Lesson 2—Input wave setup

OptiFDTD contains more features in the **Input Wave** set up and the simulation set up. The excitation set up for the simulation is done by the **Input Plane** which contain the following features:

Time Domain Input Wave formation

- Continuous Wave with single wavelength
- Pulse wave with broad band spectrum

Transverse field distribution

- Modal Input
- Gaussian beam
- Rectangular beam
- User defined Transverse

Polarization formation

- Linear polarization
- Circular Polarization

Input Wave direction

Power

Amplitude

The following procedures illustrate how to set up the input wave.

There is no specific layout used to show the input wave setup in this lesson. The text explanation and graphs are in general format only.

Note: This lesson presumes that you are familiar with the layout design and you use the sample lessons for reference.

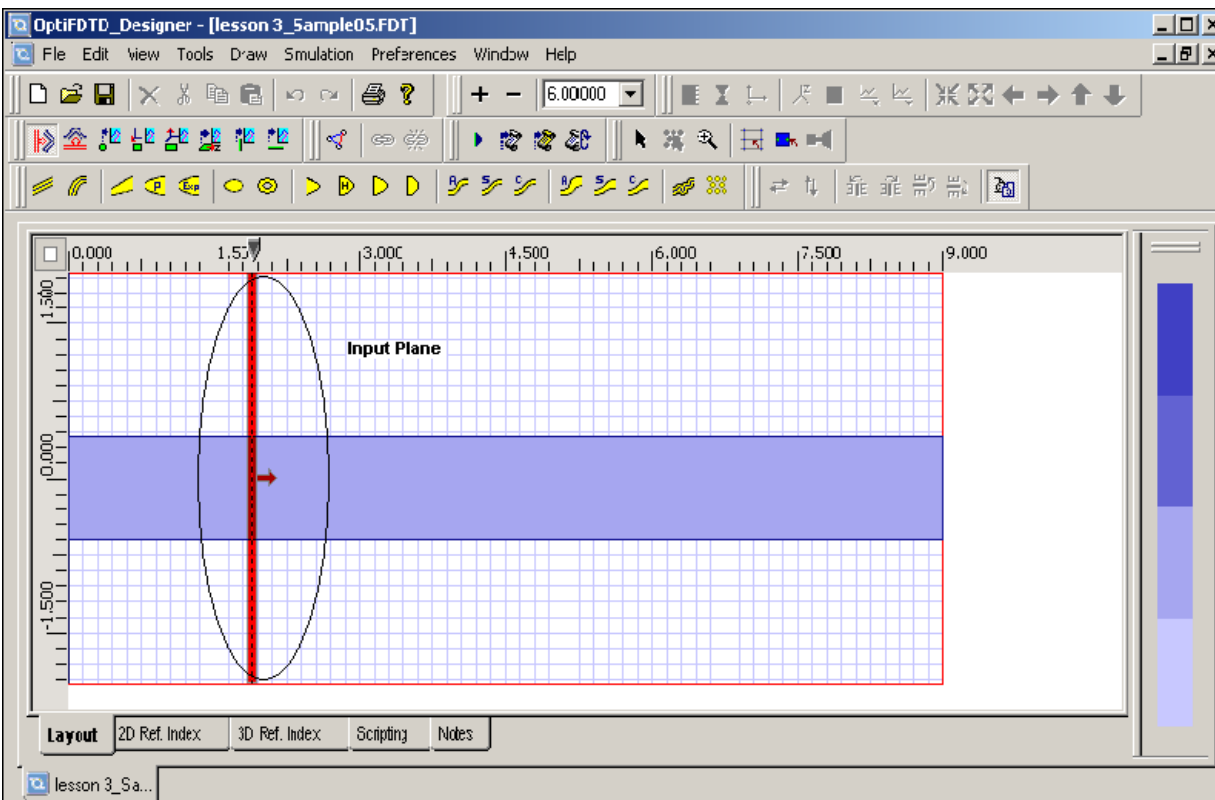


Drawing an Input plane in the layout

To draw an input plane in the layout, perform the following procedure.

- | Step | Action |
|------|---|
| 1 | From the Draw menu, select Vertical Input Plane . |
| 2 | Place the Input Plane in the layout at the desired position.
<i>A red line that presents the input plane appears in the layout window (see Figure 65).</i> |

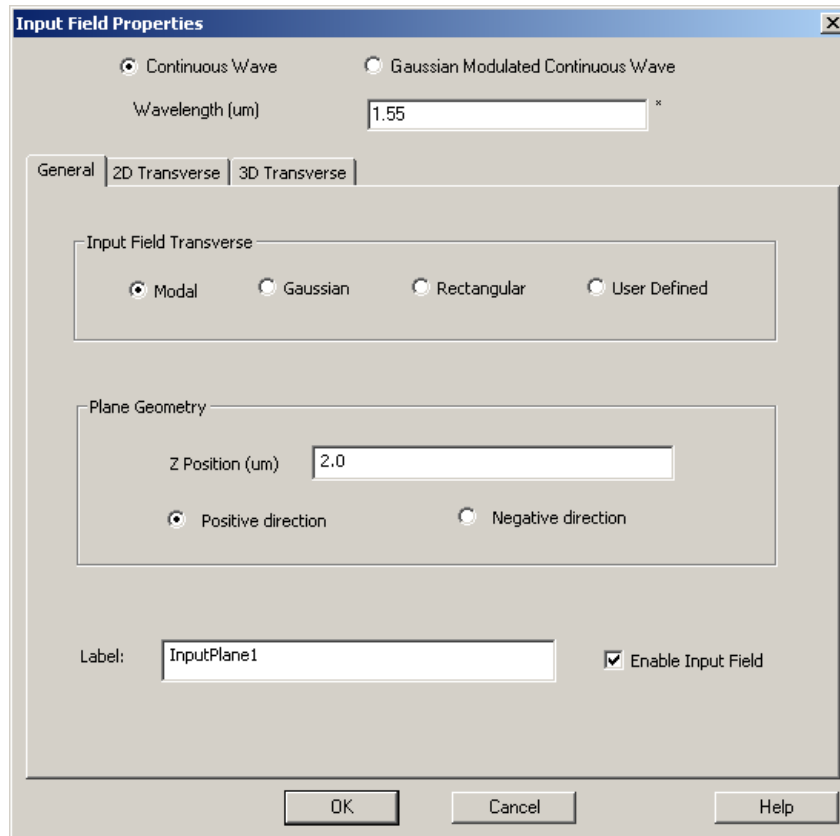
Figure 65 Vertical Input Plane



- 3 To set up the input wave properties, double-click the red line (Input Plane). *The Input Field Properties dialog box appears (see [Figure 66](#)).*



Figure 66 Input Field Properties dialog box

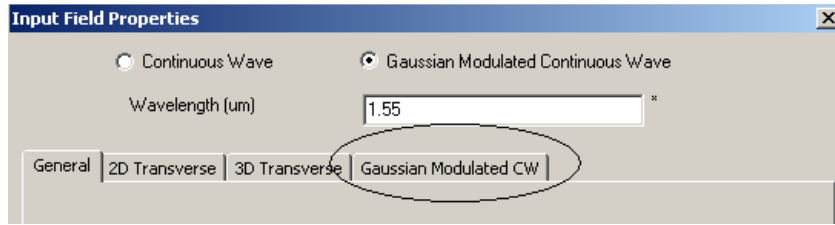


- 4 In the **Input Field Properties** dialog box, set the **Position** and the desired wave propagation direction.

Note: For 2D simulations, a multiple input plane in vertical and horizontal position can be designed.
- 5 To select a Single Wavelength Input Wave:
 - a. Click **Continuous Wave** (CW).
 - b. Type the wavelength value.
- 6 To select a Pulse Input---Spectral Input Wave:
 - a. Click **Gaussian Modulated Continuous Wave** (GMCW).
The Gaussian Modulated CW tab appears in the Input Field Properties dialog box (see [Figure 67](#)).



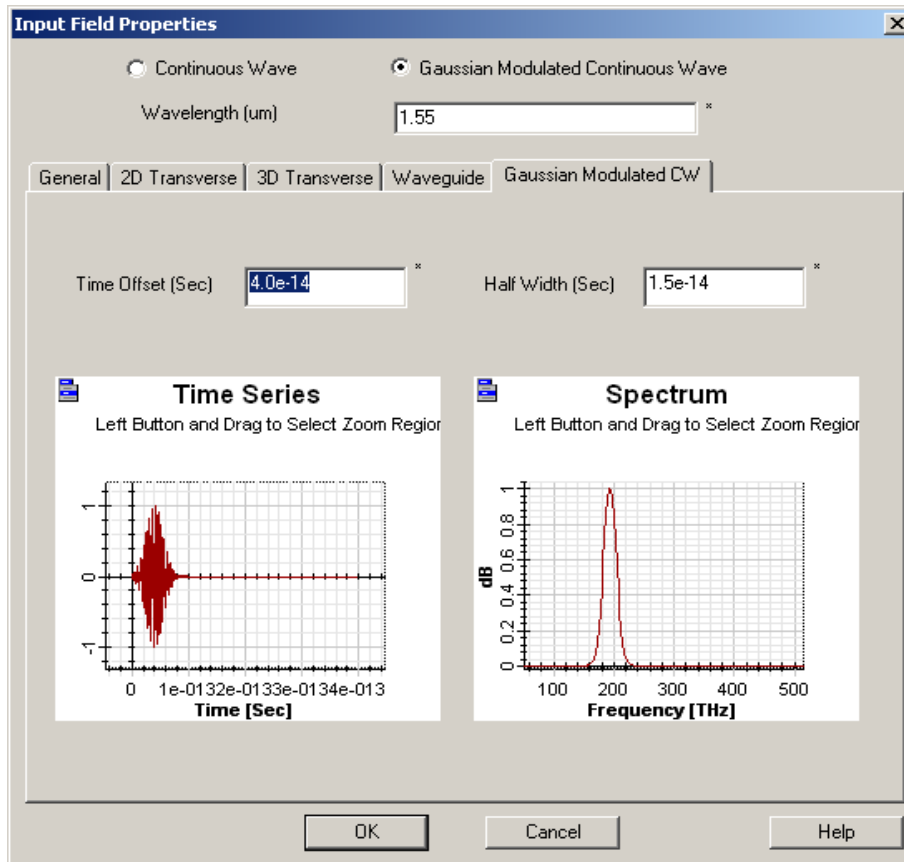
Figure 67 Input Field Properties dialog box—Gaussian Modulated CW tab



- 7 Type the center wavelength value in **Wavelength** box.
- 8 Click the **Gaussian Modulated CW** tab to edit the **Pulse** parameters.
Time domain and frequency domain input wave curves appear in the user interface (see [Figure 68](#)).

Note: Right-click on the curve to use the graph tool to view or edit the graph (zoom in or out, for example).

Figure 68 Time domain and frequency domain input wave curves

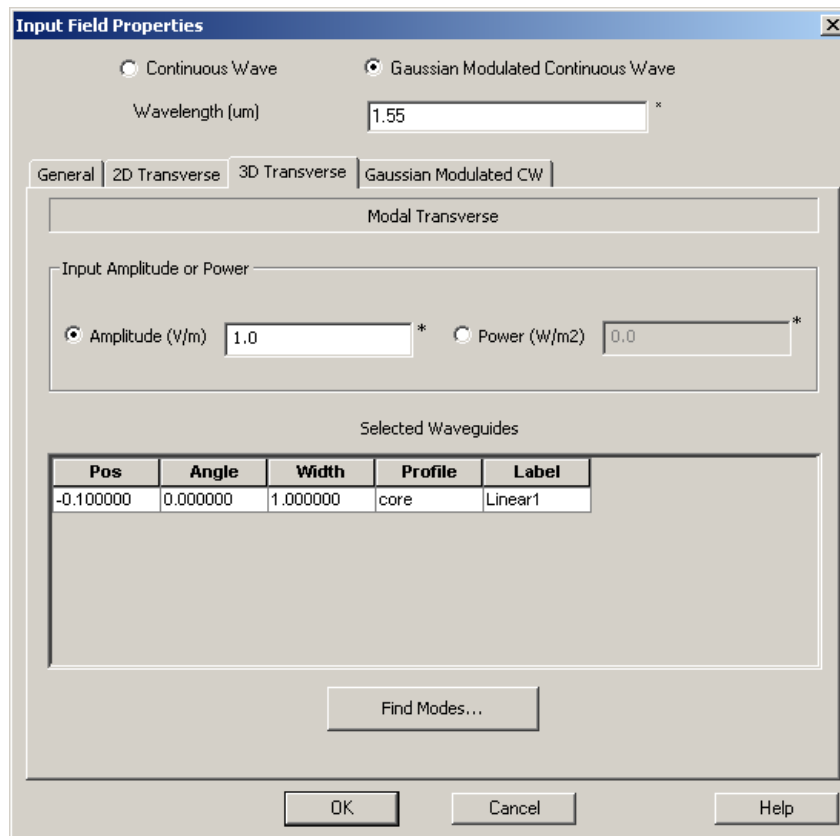


- 9 Set the time offset and the half width of the input wave in time domain.
This will adjust the spectrum width.
- 10 Right-click in the graph.
The graph tool appears.
- 11 Select **Zoom** in the toolbar, and zoom into the region to see the detail of the time domain and frequency domain wave.

Setting up the 3D Transverse Mode Input

- | Step | Action |
|------|--|
| 1 | Click the General tab to return to the Transverse selection page |
| 2 | Click Modal . |
| 3 | Click the 3D Transverse tab to solve the 3D mode.
<i>The 3D modal transverse field summary page appears (see Figure 69).</i> |

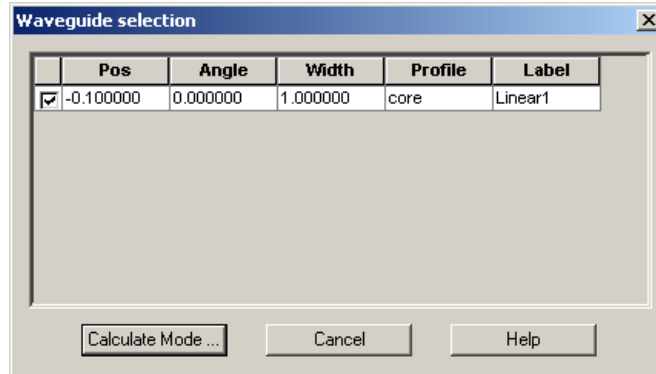
Figure 69 3D Modal Transverse field summary



- 4 Input power value or the amplitude of the input transverse mode.
Note: Amplitude value will be the maximum value of the input electrical field.

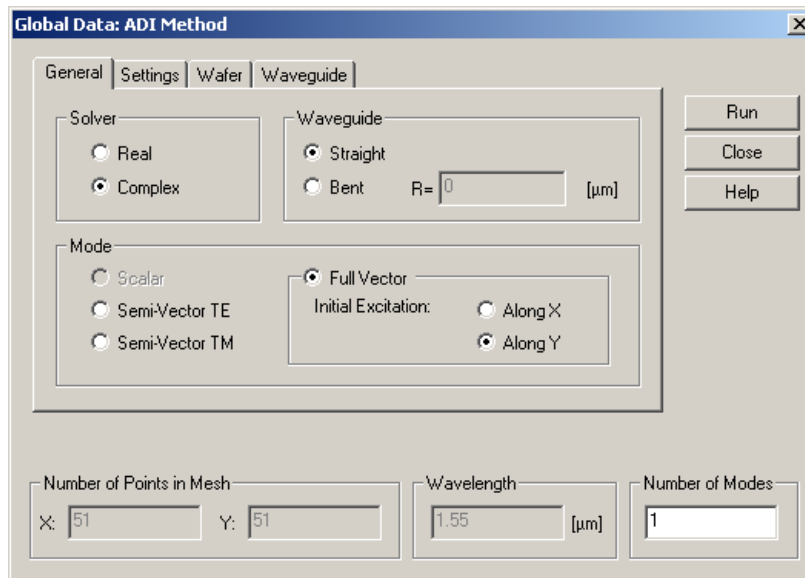
- 5 Click **Find Modes** to solve the mode.
The **Waveguide selection** dialog box appears (see [Figure 70](#)).

Figure 70 Waveguide selection dialog box



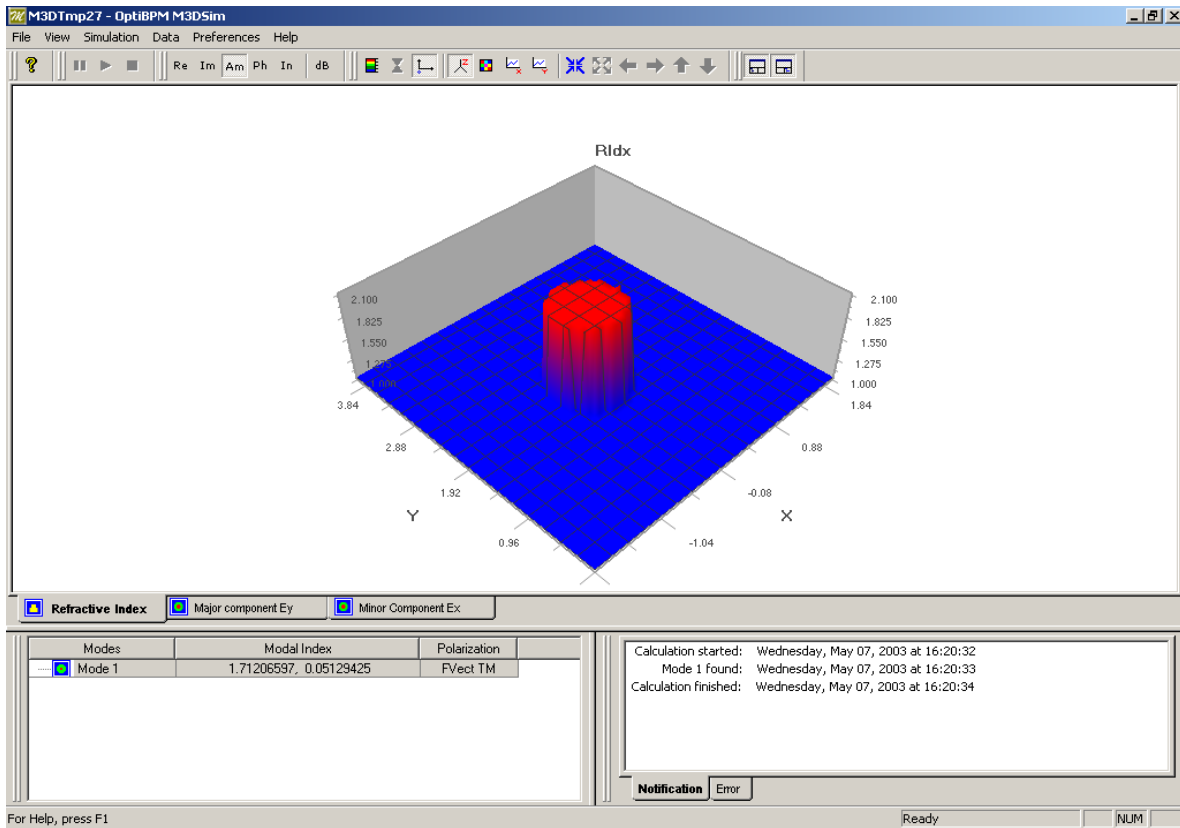
- 6 In the **Waveguide** list, select a waveguide to solve the mode.
- 7 Click **Calculate Mode**.
The **Global Data: ADI Method** dialog box appears (see [Figure 71](#)).

Figure 71 Global Data: ADI method dialog box



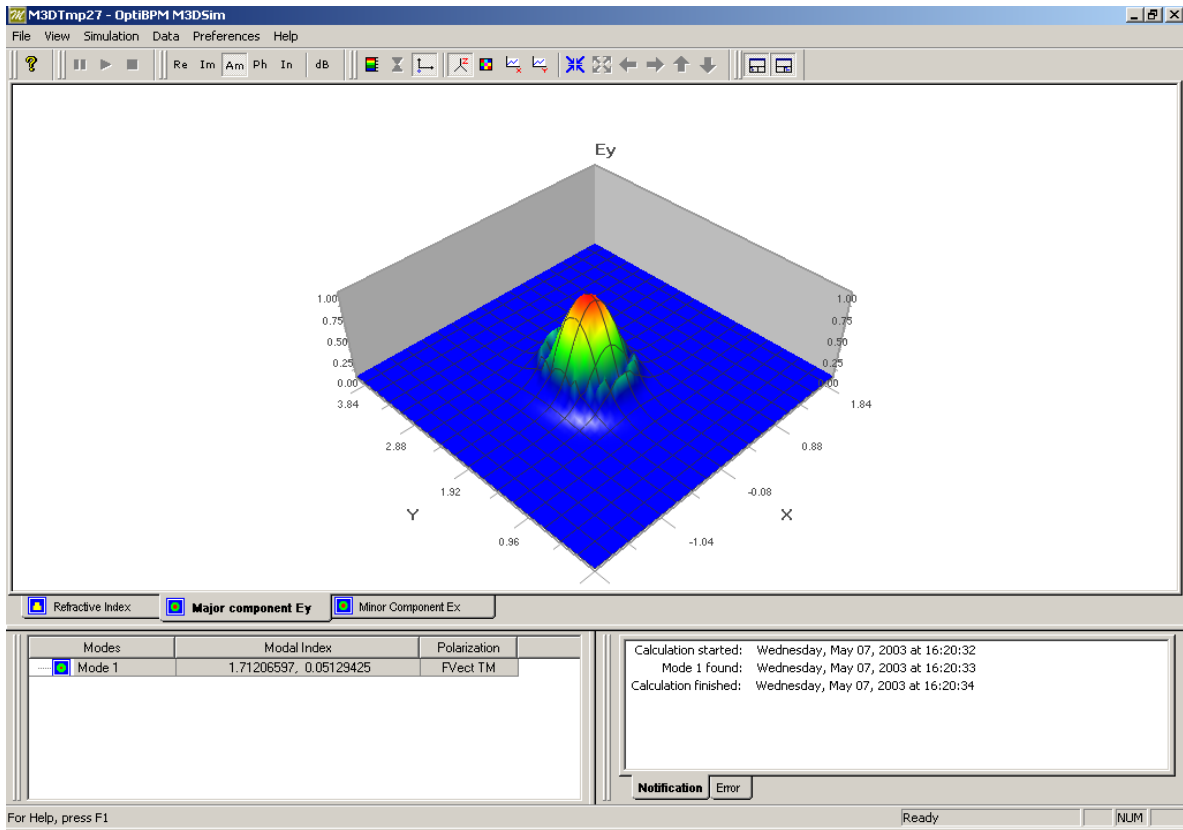
- 8 In the **Global Data: ADI Method** dialog box, set up the mode solver parameters, as shown in [Figure 71](#).
- 9 Click the **Settings** tab to set the initial guess field for solving the mode by ADI method.
Note: Three types of Boundary condition are available—Homogeneous, Neumann, and TBC. TBC is suggested.
- 10 Set the **Accuracy** and **Acceleration** parameters for controlling the mode solver.
- 11 Click the **Wafer** and **Waveguide** tabs to see the summaries of the wafer and waveguide properties.
- 12 Return to the **Global Data: ADI Method** dialog box.
- 13 Click **Run**.
The Mode Solver interface appears (see [Figure 72](#)).

Figure 72 Mode Solver interface—Refractive Index graph



When the Mode Solver finds the mode, results will be shown in the Mode solver as well as the Effective refractive index and transverse layout (see [Figure 73](#)).

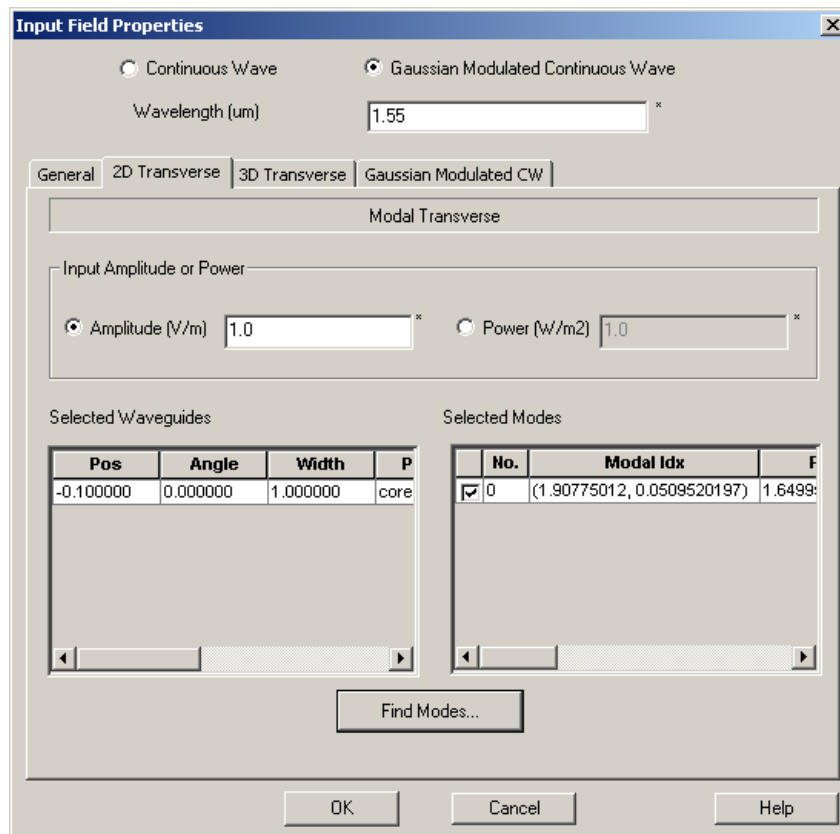
Figure 73 Major component Ey view



Setting up the 2D Transverse Mode Input

- | Step | Action |
|------|---|
| 1 | Click the General tab in the Input Plane Properties dialog box. |
| 2 | Click Modal. |
| 3 | Click the 2D Transverse tab to solve the 2D mode (see Figure 74). |

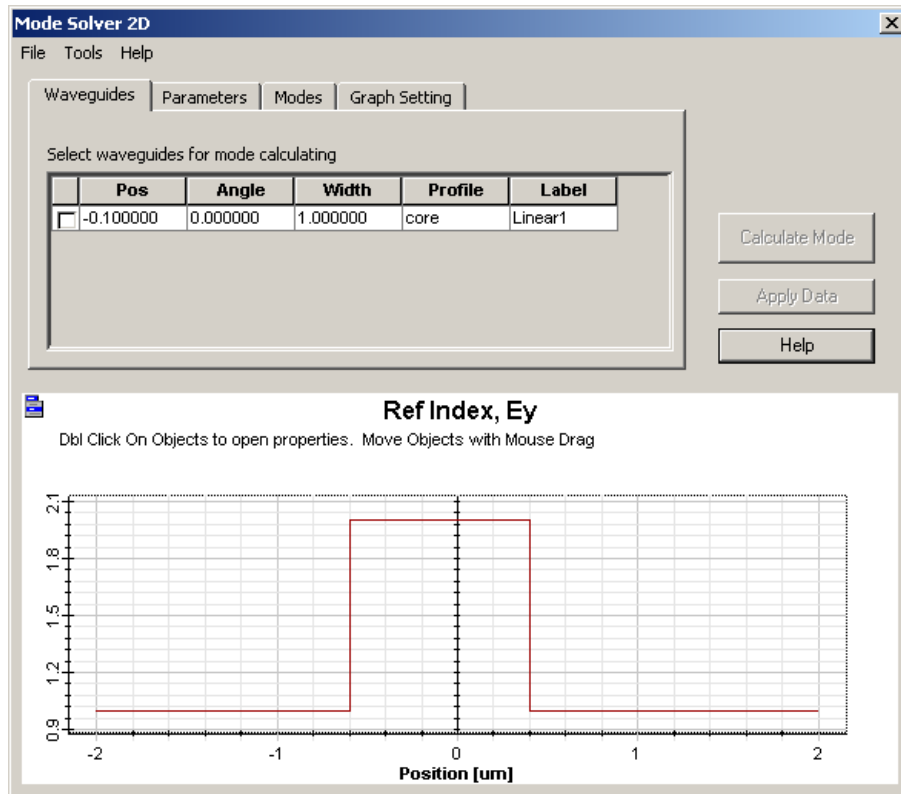
Figure 74 Input Plane Properties dialog box—2D Transverse tab



- 4 Click **Find Modes** to set the 2D mode Solver.
The Mode Solver 2D dialog box appears (see [Figure 75](#)).

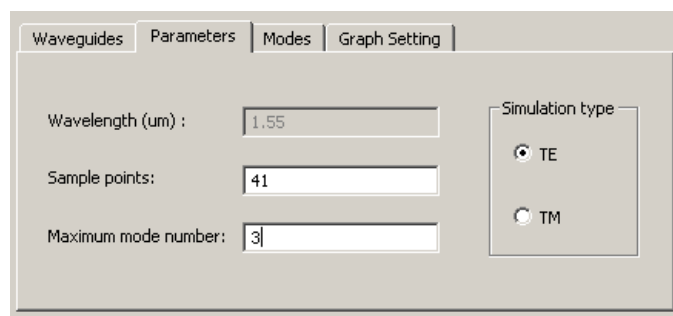


Figure 75 Mode Solver 2D dialog box



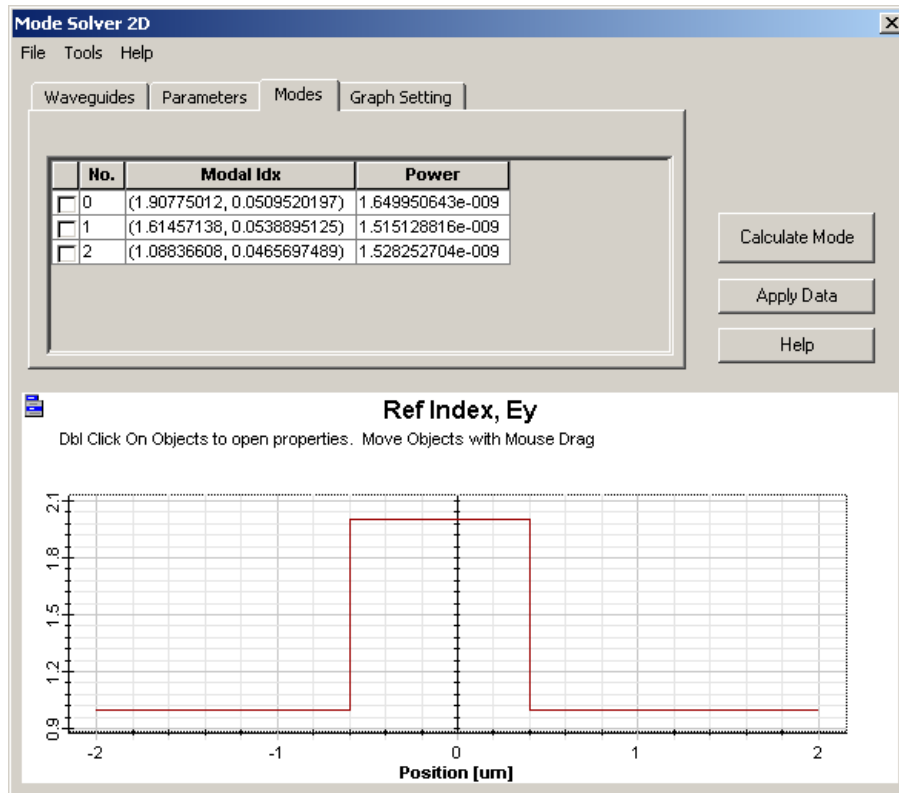
- 5 Select the waveguides for Mode calculation.
- 6 Click the **Parameters** tab to edit the calculation parameters (see Figure 76).
 - Set Sample points
 - Number of modes
 - TE or TM selection

Figure 76 Parameters tab



- 7 Click **Calculate Mode**.
The calculation summary appears in the **Mode Solver 2D** dialog box (see [Figure 77](#)).

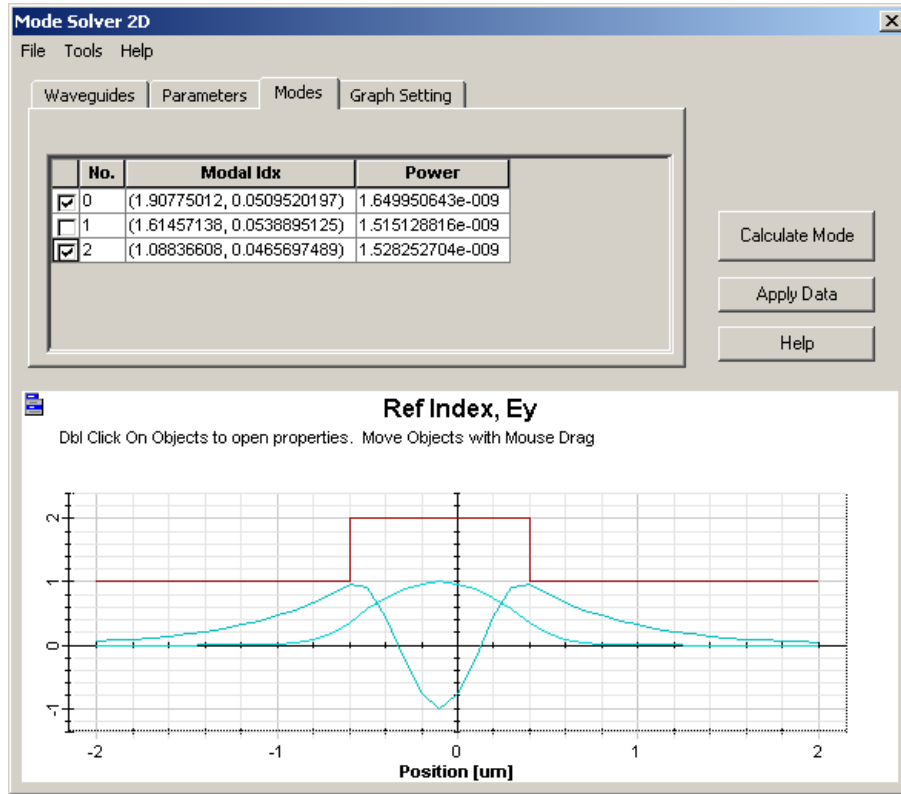
Figure 77 Mode Solver 2D dialog box—Modes tab



- 8 From the mode list, select the mode.
The mode distribution will be shown in the dialog box (see [Figure 78](#)).



Figure 78 Mode Solver 2D dialog box



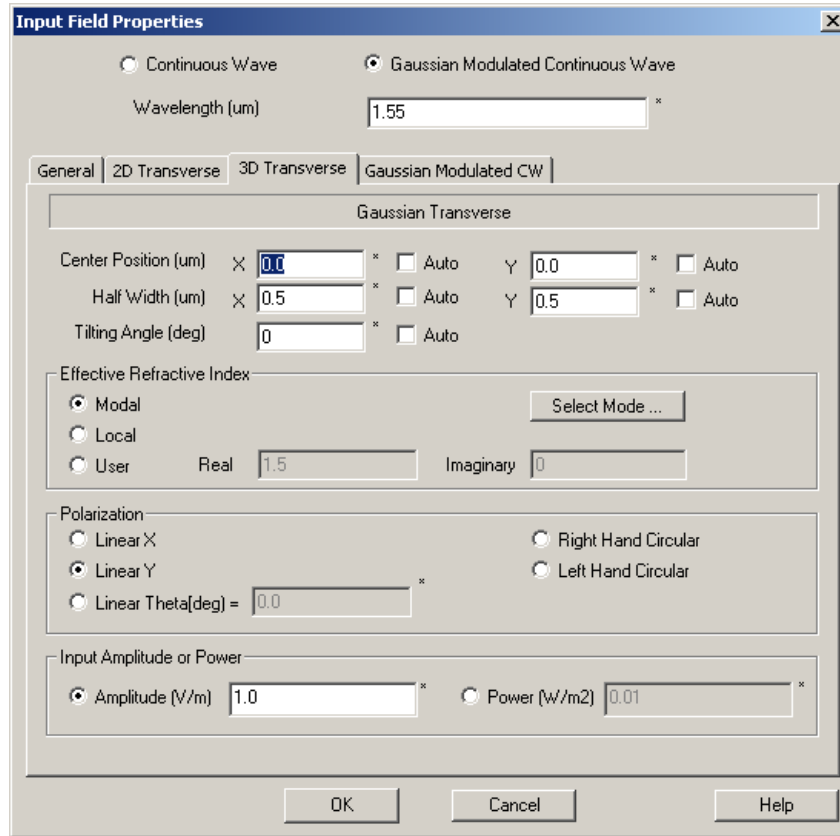
- 9 Click **Graph Setting** to select the graph feature.
- 10 Select a mode and click **Apply Data**.
This mode will be used as the 2D transverse input wave.

Setting up the 3D Transverse Gaussian Beam Input

- | Step | Action |
|------|---|
| 1 | Click the General tab in the Input Field Properties dialog box. |
| 2 | In the Input Field Transverse area, select Gaussian . |
| 3 | Click the 3D Transverse tab.
<i>The 3D Transverse tab appears (see Figure 79).</i> |

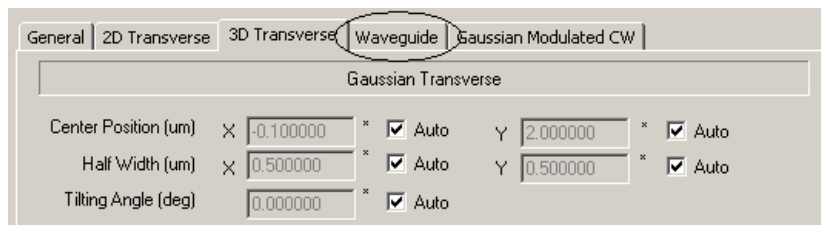


Figure 79 3D Transverse dialog box



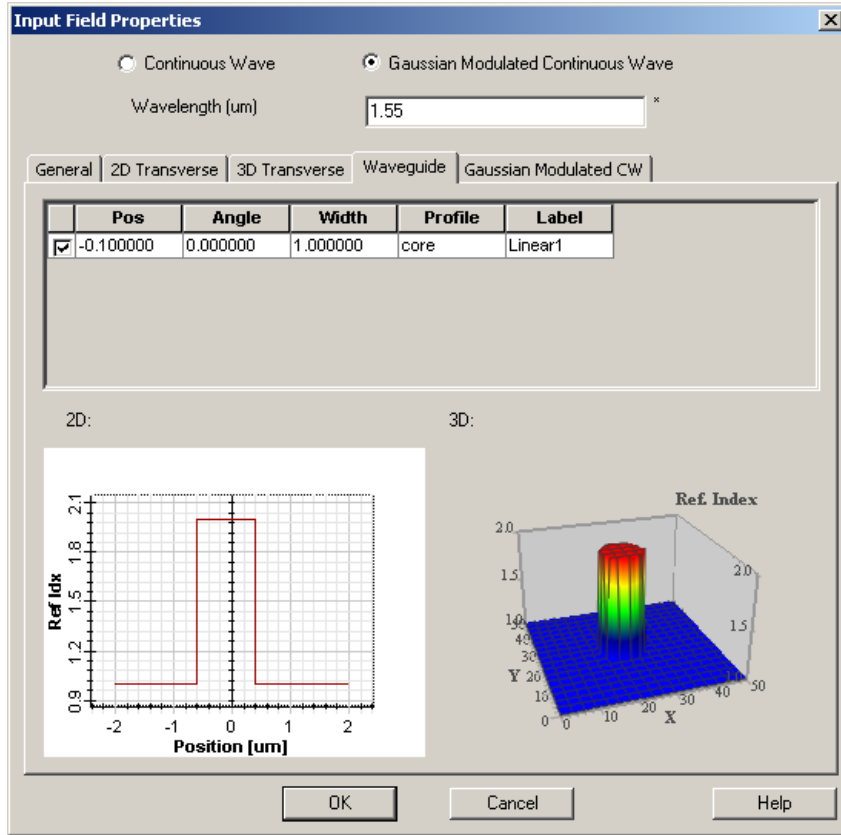
- 4 Define the Gaussian beam in the Gaussian Transverse region.
- 5 Select the **Auto** check box.
The Waveguide tab appears (see Figure 80).

Figure 80 Waveguide tab



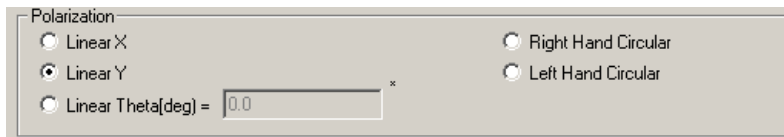
- Click the waveguide in the list to observe the position (see [Figure 81](#)).

Figure 81 Waveguide position



- Click the **3D Transverse** tab, and select **Modal**, **Local**, or **User** in the **Effective Refractive Index** area.
Note: This refractive index will be used for calculating the magnetic components from electrical components and calculating the projection field if the tilting waveguide is used.
- Specify the Gaussian beam polarization formation in the **Polarization** area (see [Figure 82](#)).

Figure 82 Polarization area



OptiFDTD provides five polarization options:

- Linear X
 - Linear Y
 - Linear Theta
 - Left Hand Circular
 - Right Hand Circular
- 9 Set the Gaussian beam's power and amplitude.

Setting up the 2D Transverse Gaussian Beam Input

A 2D Gaussian beam setup is the same as 3D definition except that:

- 2D Gaussian beam is defined in one dimension
- TE /TM polarization

Setting up the 3D Transverse Rectangular Beam

The setup for a 3D rectangular beam is the same as that of the 3D Gaussian beam, except the wave formation stays in a rectangular shape in the rectangular region.

Setting up the 2D Transverse Plane Wave Input (rectangular beam)

The setup for a 2D rectangular beam is same as that of the 2D Gaussian beam, except the wave formation stays in a rectangular shape in the rectangular region.

Point Source

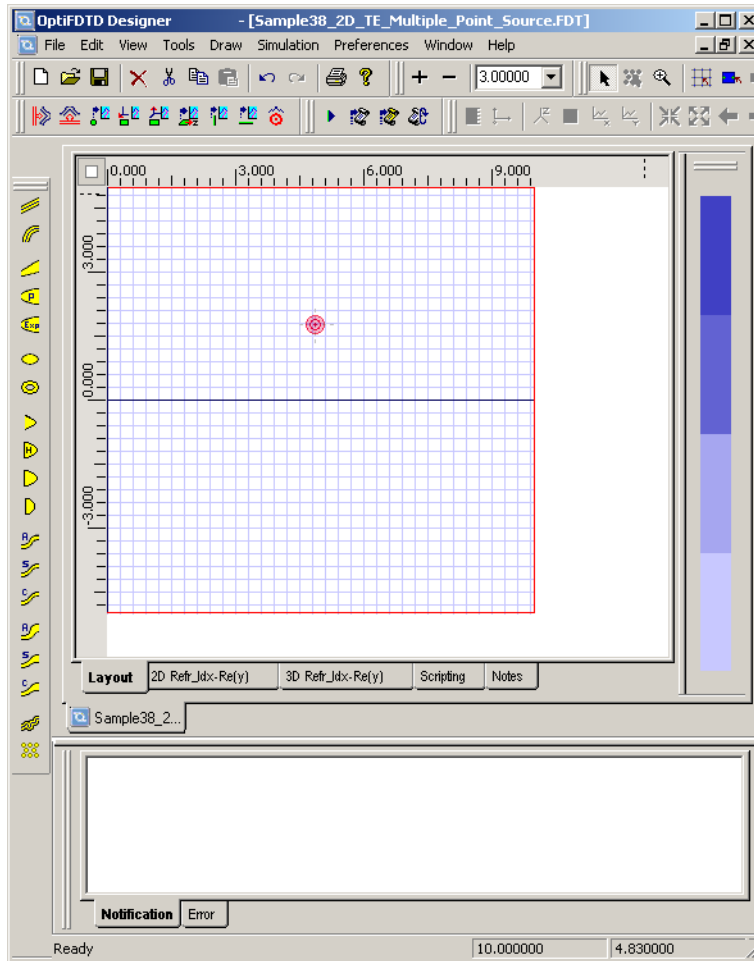
More information regarding the Point Source can be found in the Technical Background.

Setting up a Point Source

- | Step | Action |
|-------------|---|
| 1 | Click Select Point Source from the toolbar. |
| 2 | Place the Input Plane in the layout at the desired position.
<i>A red circle indicates the location of the point source (see Figure 83).</i> |



Figure 83 Point Source in Input Plane layout



- 3 To set up the input wave properties, double-click the **Point Source** in the layout.
*The **Point Source Properties** dialog box appears.*



Figure 84 Point Source Properties dialog box

- 4 In the **Point Source Properties** dialog box, set up the position information:

Note:

- Horizontal direction is z-direction
- Vertical direction is x-direction
- Depth controls the y-direction which is for 3D simulation.

- 5 Specify the **Time Domain Waveform** and enter a value in **Wavelength**.

Note: If you want to use **Gaussian Modulated Continuous Wave**, select **Gaussian Modulated Continuous Wave** in the **Time Domain Waveform Selection** dialog box.

- 6 Enter the **Amplitude** value in the **Amplitude** box (bottom right).

- 7 In the **3D Field Component** area, select an electrical component to hold the point source.

Note: For 2D TE simulation, the point source is functional to major component E_y . For 2D TM simulation, point source is functional to major component H_y .

Note: You can edit any point source using the **Point Source Properties** dialog box by making a selection from the drop-down list accessible with **Select a point source**. Also, multiple point sources can be placed in the same position.





Lesson 3—Photonic crystal and photonic band gap simulation

OptiFDTD provides comprehensive design, simulation, and post-analysis tools for photonic crystal (PhC) and photonic band gap (PBG) analysis:

- layout designer provides the tools to define the lattice relation, atom properties, defects, wave path, and observation projects
- band solver is an independent simulation engine that gives the band-diagram for the defined lattice structure
- simulator can perform the plane wave simulation based on the periodic cell with a periodic boundary condition
- analyzer can view the field pattern and extract the transmittance/reflection coefficients

Note: The band solver is investigated in Lesson 9.

This lesson includes two samples:

- Sample 1 demonstrates how to define the PBG layout and how to extract the transmittance/reflection. The corresponding project file can be found in the Samples folder: **Sample10_2D_TE_PBG_Y_Branch.FDT**.
- Sample 2 demonstrates a plane wave simulation based on the periodic cell of PhC. The corresponding project file can be found in the Samples folder: **Sample09_2D_TE_PBG_Domain_Reduced_Square_Lattice.FDT**.

Sample 1---PGB Layout

Designing a PBG structure

To design a PBG structure, perform the following procedures.

- | Step | Action |
|-------------|--|
| 1 | Start Waveguide Layout Designer . |
| 2 | To create a new project, select File > New .
<i>The Initial Properties dialog box appears.</i> |
| 3 | Click Profiles and Materials .
<i>The Profile Designer window appears.</i> |
| 4 | Under the Materials folder of OptiFDTD Designer1, right-click the Dielectric folder and select New .
<i>A new Dielectric material dialog box appears.</i> |
| 5 | Type the following information:
Name: PBG_atom
Refractive index (Re:): 3.1 |
| 6 | To save the material, click Store . |



PBG_atom appears in the **Dielectric** folder in the directory and in the dialog box title bar.

To define the channel profile, perform the following procedure.

- | Step | Action |
|-------------|---|
| 1 | Under the Profiles folder of OptiFDTD Designer1, right-click the Channel folder and select New .
<i>The ChannelPro1 dialog box appears.</i> |
| 2 | Create the following channel profile:
Profile name: Profile_PBG
2D profile definition
Material: PBG_atom
3D profile definition
Layer name: layer_01
Width: 1.0
Thickness: 1.0
Offset: 0.0
Material: PBG_atom |
| 3 | Click Store . |
| 4 | Close the Profile Designer . |

To define the wafer and waveguide properties, perform the following procedure.

- | Step | Action |
|-------------|---|
| 1 | In the Initial Properties dialog box, , type/select the following:
Waveguide Properties
Width [μm]: 1.0
Profile: Profile_PBG
Wafer Dimensions
Length [μm]: 21.0
Width [μm]: 15.0
2D Wafer Properties
Material: Air
3D Wafer Properties
Cladding
Thickness [μm]: 1.0
Material: Air
Substrate
Thickness [μm]: 1.0 |



Material: **Air**

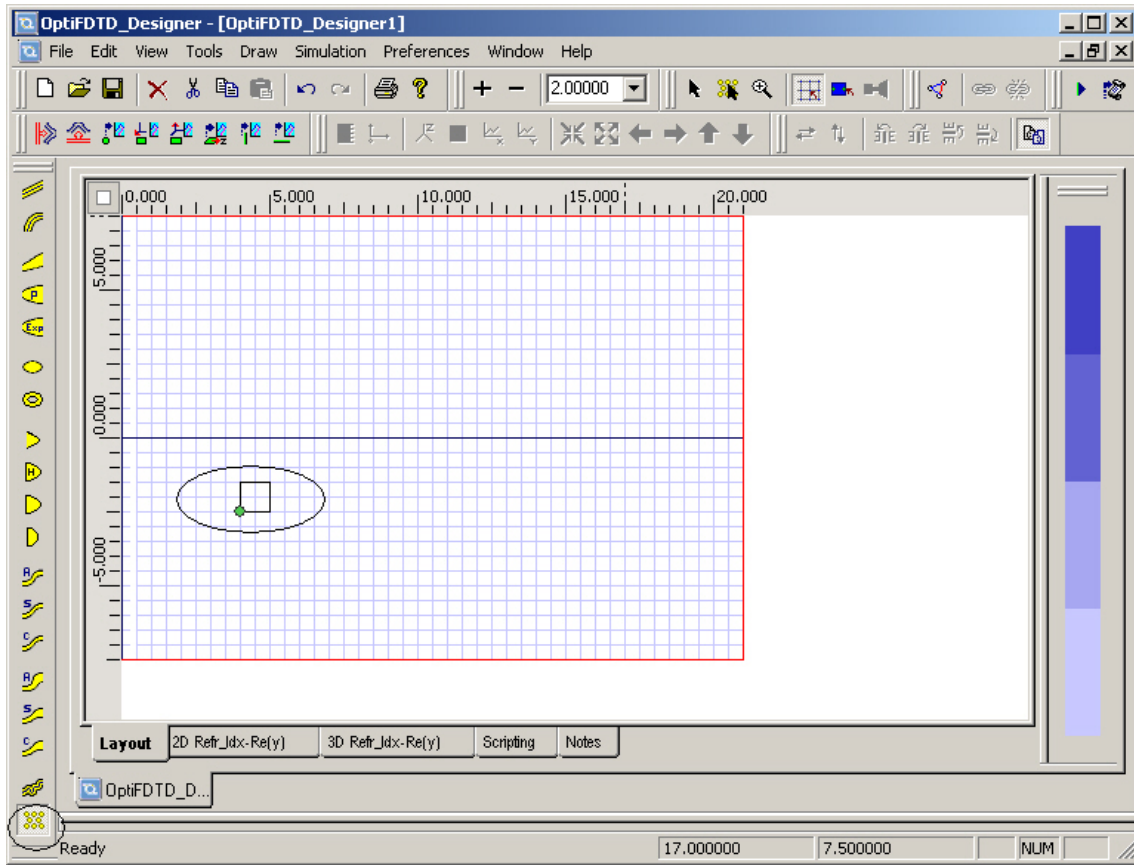
- 2 Click **OK**.
*The **Initial Properties** dialog box closes.*



Creating the PBG structure

- | Step | Action |
|------|--|
| 1 | From the Draw menu, select PBG Crystal Structure . |
| 2 | In the layout window, drag the cursor from a designated starting point and release, to create the PBG area.
<i>The PBG Crystal Structure appears in the layout window (see Figure 85).</i> |

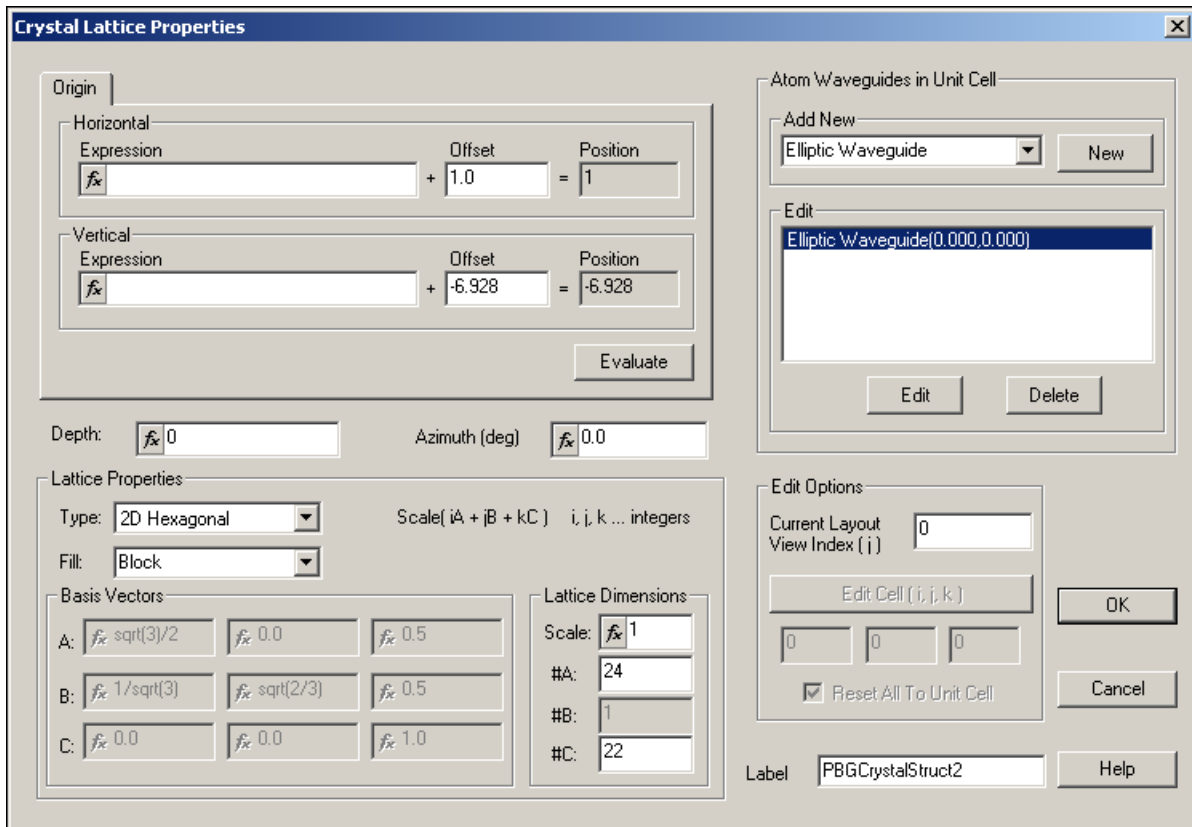
Figure 85 PBG crystal structure in layout



- | | |
|---|---|
| 3 | To edit the crystal structure, double-click on the PBG structure in the layout.
<i>The Crystal Lattice Properties dialog box appears (Figure 86).</i> |
|---|---|



Figure 86 Crystal Lattice Properties dialog box



- 4 In **Origin**, **Offset**, type/select the following:
 Horizontal: 1.0
 Vertical: -6.928
- 5 Click **Evaluate**.
- 6 Type/select the following:
 Depth: 0.0
 Azimuth [deg]: 0.0
- 7 In **Lattice Properties**, Type, select **2D Hexagonal**.
- 8 In **Fill**, select **Block**.
- 9 In **Lattice Dimensions**, type/select the following:
 Scale: 1.0
 #A: 17
 #C: 19
Note: When a 2D lattice is selected, the Y-direction cell **#B** is set to the default value of 1.
- 10 In **Label**, type **PBGCrystalStruct1**.

Note: Do **NOT** close the **Crystal Lattice Properties** dialog box.

Setting the atom properties

To set the atom properties, perform the following procedure in the **Crystal Lattice Properties** dialog box.

- | Step | Action |
|-------------|---|
| 1 | In Atom Waveguide in Unit Cell, Add New , select Elliptic Waveguide from the drop-down menu and click New .
<i>The Elliptic Waveguide Properties dialog box appears (see Figure 87).</i> |
| 2 | In Center, Offset , type/select the following:
Horizontal: 0.0
Vertical: 0.0 |
| 3 | Type/select the following:
Major radius: 0.3
Minor radius: 0.3
Orientation angle: 0.0
Channel thickness tapering: Use Default (Channel: None)
Depth: 0.0
Label: Atom
Profile: Profile_PBG . |
| 4 | Click OK .
<i>The Elliptic Waveguide Properties dialog box closes.</i> |

Note: When you return to the **Crystal Lattice Properties** dialog box, you will see the defined elliptic waveguide listed in **Atom Waveguide in Unit Cell**.

Note: If you close the **Crystal Lattice Properties** dialog box, you will see the defined PBG structure in the layout window (see [Figure 88](#)).



Figure 87 Elliptic Waveguide Properties dialog box

Elliptic Waveguide Properties

Center

Horizontal
 Expression: f_x + Offset: 0 = Position: 0

Vertical
 Expression: f_x + Offset: 0 = Position: 0

Evaluate

Major radius:
 f_x + 0.3 = 0.3

Minor radius:
 f_x + 0.3 = 0.3

Orientation angle:
 f_x + 0 = 0

Channel Thickness Tapering
 Use Default (Channel:None) Taper: Default (None)
 Start: f_x 1.0 End: f_x 1.0

Width:

Depth:

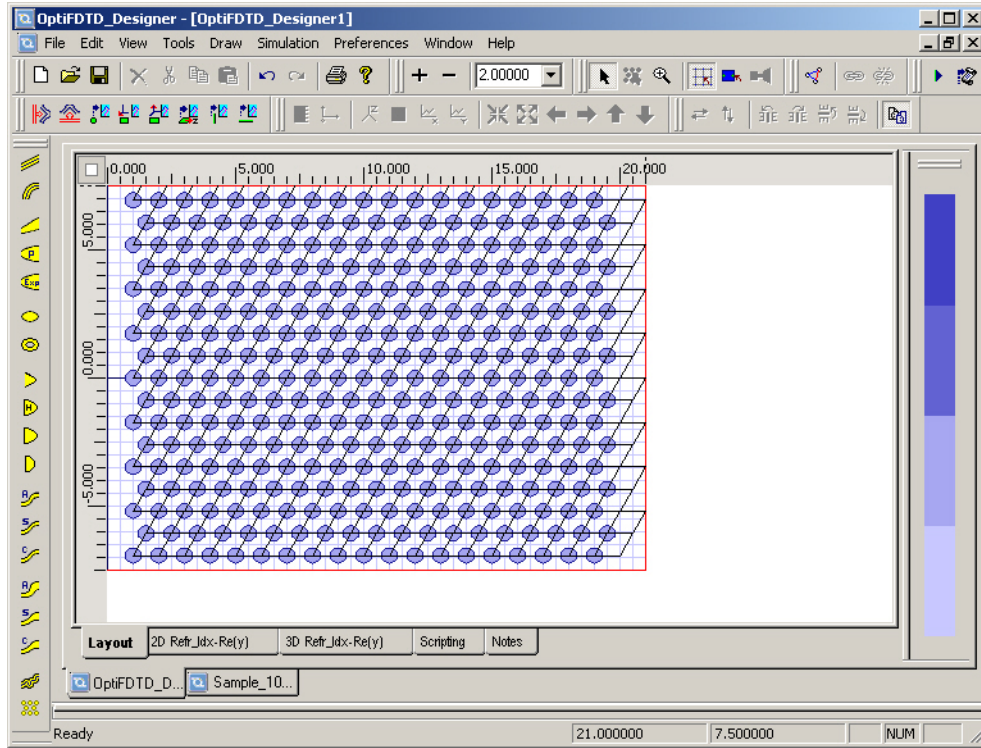
Label:

Profile: Profiles In Use...

OK
 Cancel
 Help
 Evaluate



Figure 88 PBG structure in layout window



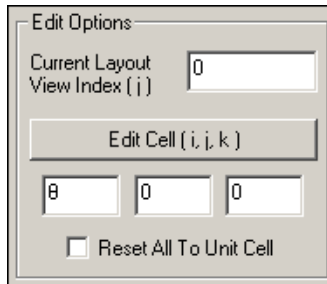
There are three ways to create a cell with special properties.

Step Action

- 1 In the **Crystal Lattice Properties** dialog box, set the cell position nodes:

Edit Options

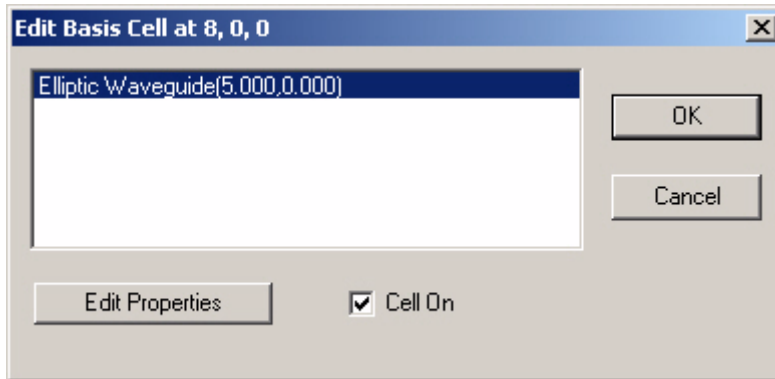
- i: 8
- j: 0
- k: 0



- 2 Click **Edit Cell (i,j,k)** button.
The **Edit Basis Cell** dialog box appears (see [Figure 89](#)).



Figure 89 Edit Basis Cell dialog box



Note: To deactivate the basic cell, deselect **Cell On**. The region will then be recovered to the wafer material.

- 3 Select an atom in the list to edit (in this case, **Elliptic Waveguide [5.000, 0.000]**).
- 4 Click **Edit Properties**.
*The **Elliptic Waveguide Properties** dialog box appears.*
- 5 Type/select the following:
Major radius: 0.5
Minor radius: 0.4
- 6 Click **OK**.

The cell's index definition for Hexagonal is shown in [Figure 90](#).

Figure 90 Cell index definition for Hexagonal

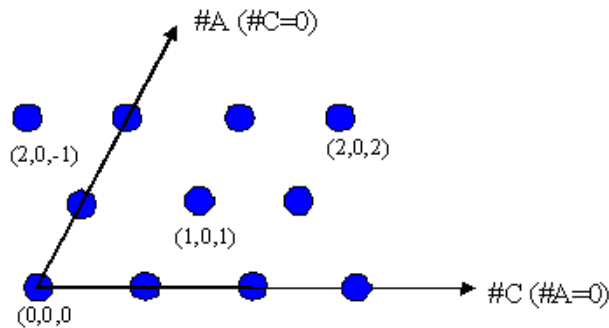
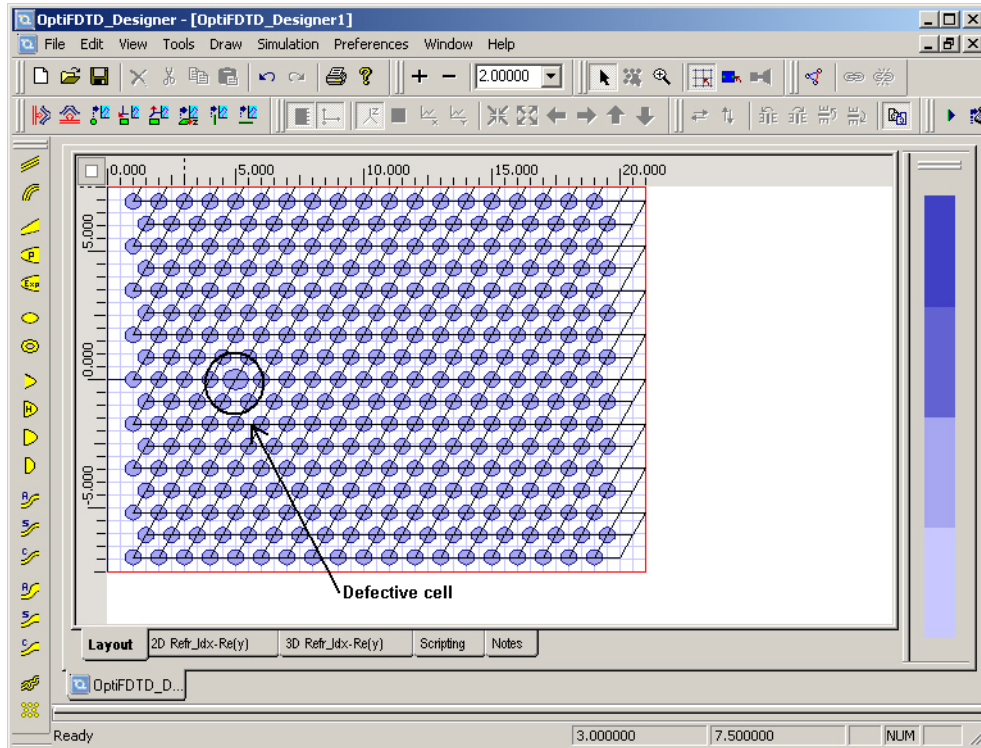


Figure 91 PBG layout with defective cell



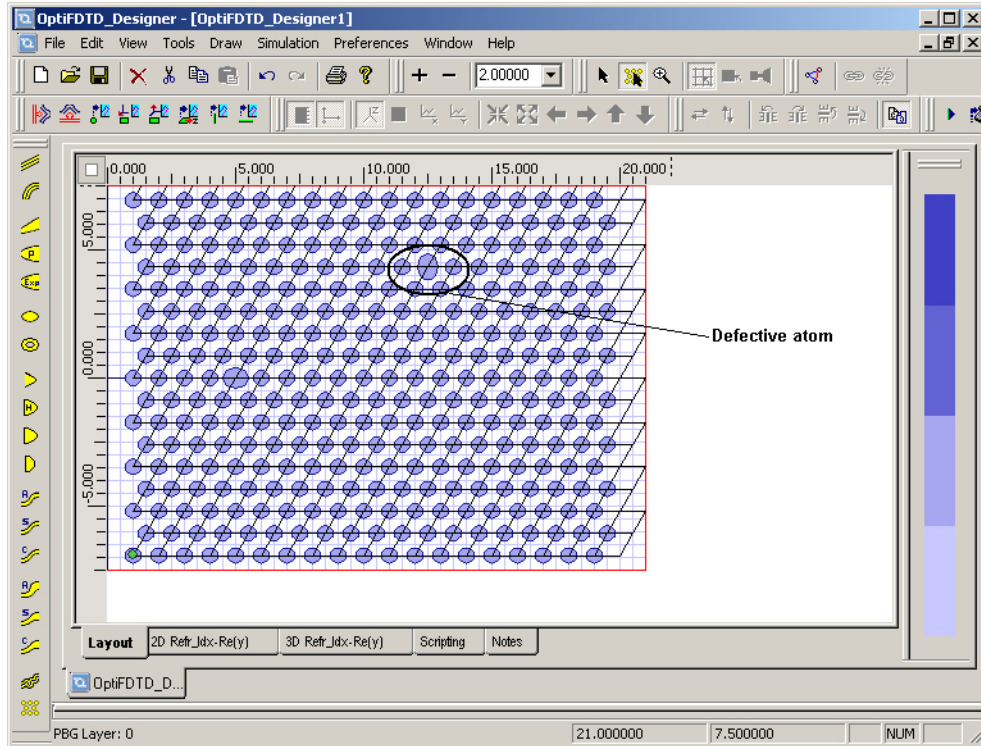
OR

Step Action

- 1 In the layout designer, to select the PBG lattice, click the PBG area.
*A green dot appears in the PBG structure and the **PBG Crystal Structure Cell Editing Tool** becomes active.*
- 2 Select the **PBG Crystal Structure Cell Editing Tool** icon.
- 3 Double click on the atom in the Cell (13, 0, 5).
*The **Elliptic Waveguide Properties** dialog box appears.*
- 4 Type/select the following:
Major radius: 0.4
Minor radius: 0.5
- 5 Click **OK** to return to the layout window.
The atom at cell (13,0,5) becomes the defective atom (see [Figure 92](#)).



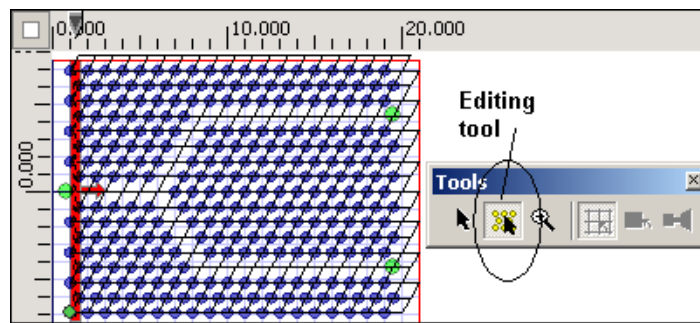
Figure 92 Defective atom at Cell 13,0,5



OR

Step Action

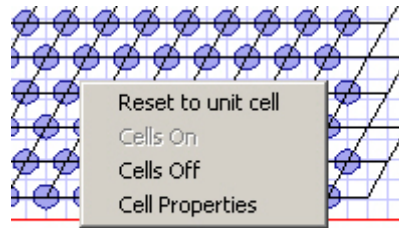
- 1 In the layout designer, to select the PBG lattice, click the PBG area.
A green dot appears in the PBG structure and the **Tools** toolbar, including the **PBG Crystal Structure Cell Editing Tool**, becomes active.



- 2 Select the **PBG Crystal Structure Cell Editing Tool**, and right-click on the atom in cell (3, 0, 10).
The **PBG Cell Edit** context menu appears (see [Figure 93](#)).
- 3 Select **Cell Properties**.
The **Edit Basis Cell at 3,0,10** dialog box appears.

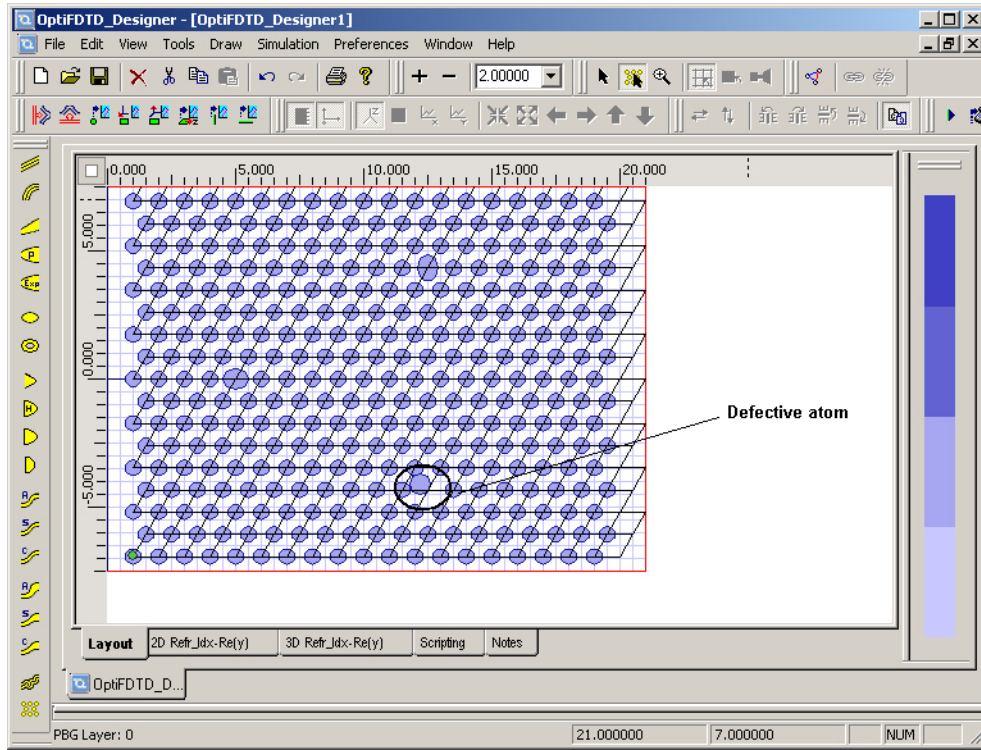
- 4 Click **Edit Properties**.
The **Elliptic Waveguide Properties** dialog box appears.
- 5 Type/select the following:
Major radius: 0.3
Minor radius: 0.3

Figure 93 PBG Cell Edit context menu



- 6 In **Center, Offset**, type/select the following:
Horizontal: 12.2
Vertical: -4.1
- 7 Click **OK** to close the **Elliptic Waveguide Properties** dialog box.
- 8 Click **OK** to close the **Edit Basis Cell at 3,0,10** dialog box.
The atom at cell (3,0,10) becomes the defective atom (see Figure 94).

Figure 94 Defective atom at Cell 3,0,10



In general, you define the lattice and atom for all the cells in the **PBG Lattice Properties** dialog box. This is called the **Unit cell** information. It works like a template; the information in a specified cell is called **Basic Cell** information. The defect is made in the selected basic cell.

In order to reset defective cells to the unit cell properties, in the **Crystal Lattice Properties** dialog box, **Reset All to Unit Cell** must be selected.

Note: If you already tried this, please select **Undo** in the **Edit** menu, because the next step in this lesson uses the layout including the defective cells.

Recovering a defective cell at (8, 0, 0) to unit cell

Step Action

- 1 In the layout designer, to select the PBG lattice, click the PBG area.
*A green dot appears in the PBG structure and the **Tools** toolbar, including the **PBG Crystal Structure Cell Editing Tool**, becomes active.*
- 2 Select the **PBG Crystal Structure Cell Editing Tool**, and right-click on the atom in cell (8, 0, 0).
*The **PBG Cell Edit** context menu appears.*
- 3 Select **Reset to Unit Cell**.
The cell values are reset to correspond to the basis cell.

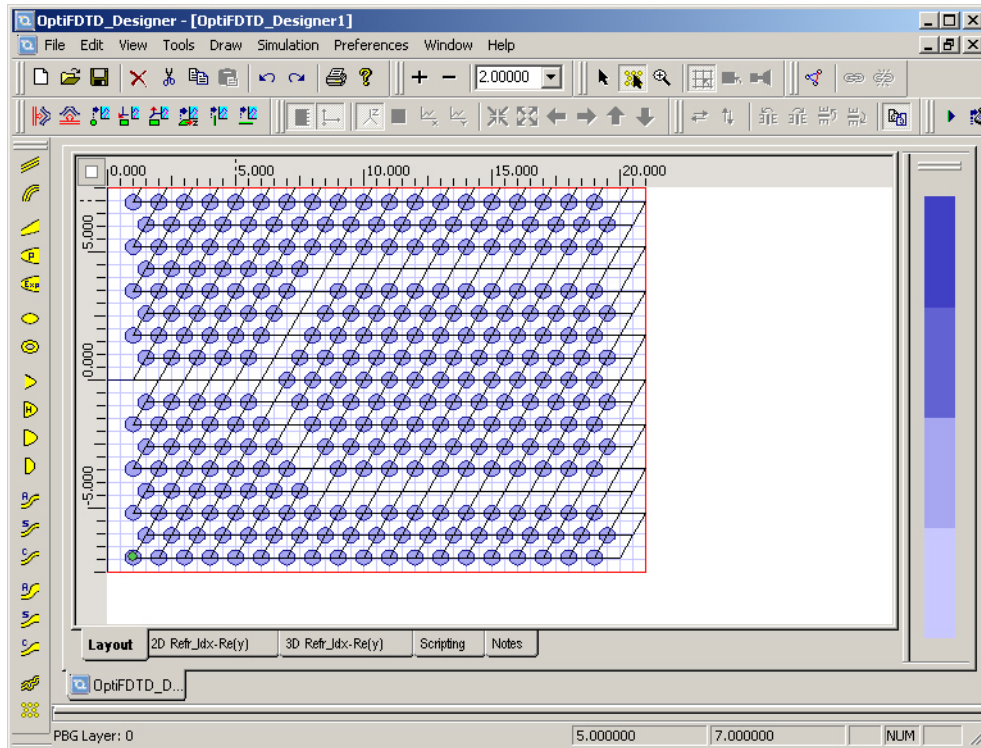
Now you will create a Y-branch wave path in this PBG layout.

Step Action

- 1 In the layout designer, to select the PBG lattice, click the PBG area.
*A green dot appears in the PBG structure and the **Tools** toolbar, including the **PBG Crystal Structure Cell Editing Tool**, becomes active.*
- 2 Select the **PBG Crystal Structure Cell Editing Tool**, and right-click on the atom in cell (8, 0, -4).
*The **PBG Cell Edit** context menu appears.*
- 3 Select **Cells Off**.
The cell is disabled.
- 4 Repeat steps 2 to 3 to disable the following cells:
 - (8,0,-3) to (8,0,1)
 - (9,0,1) to (13,0,1)
 - (13,0,2) to (13,0,12)
 - (7,0,2), (6,0,3),(5,0,4), (4,0,5)
 - (3,0,6) to (3,0,17)



Figure 95 PBG layout with new wavepath



Now you have finished the PBG layout. The next step is to set up the FDTD simulation.

After you define a lattice, you can use the FDTD band solver to get the preliminary band-diagram (see “[Lesson 9—FDTD Band Solver](#)” on page 263).

The PBG layout can also be defined by using VB scripting. The corresponding sample file for VB scripting can be found in the Samples folder:

sample21_Vbscript_PBG_Layout.FDT.

Inserting the input plane

To insert the input plane, perform the following procedure.

- | Step | Action |
|-------------|--|
| 1 | From the Draw menu, select Vertical Input Plane . |
| 2 | To insert the input plane, click in the layout window where you want it placed.
<i>The input plane appears in the layout.</i> |
| 3 | To edit the input plane, double-click on the input plane in the layout.
<i>The Input Plane Properties dialog box appears.</i> |
| 4 | Set Wavelength to 1.9 μm . |
| 5 | Select Gaussian Modulated Continuous Wave . |
| 6 | On the Gaussian Modulated CW tab, type/select the following:
Time Offset [Sec]: 5.5e-14
Half Width [Sec]: 1.1e-14 |



- 7 On the **General** tab, select Input Field Transverse: **Gaussian**.
- 8 On the **2D Transverse** tab, type/select the following:
 - Center Position [μm]: **0 . 0**
 - Halfwidth [μm]: **0 . 8**
 - Tilting Angle [deg]: **0 . 0**
 - Effective Refractive Index: **Local**
 - Amplitude [V/m]: **1 . 0**
- 9 On the **General** tab, type/select the following:
 - Plane Geometry
 - Z Position [μm]: **1 . 3**
 - Positive direction
- 10 Click **OK**.
*The **Input Field Properties** dialog box closes.*

Setting up the Observation Point

- | Step | Action |
|------|---|
| 1 | From the Draw menu, select Observation Point . |
| 2 | Place the Observation Point in the desired position in the layout. |
| 3 | Double-click the observation point.
<i>The Observation Properties -- Point dialog box appears.</i> |
| 4 | On the General tab: <ul style="list-style-type: none"> In Center, Offset, type/select the following: <ul style="list-style-type: none"> Horizontal: 19 . 5μm Vertical: 4 . 33μm Center depth: 0 . 0 μm Label: Observation Point1 |
| 5 | On the Data Components tab, ensure that 2D TE: Ey is selected (default). |
| 6 | Click OK .
<i>The Observation Properties -- Point dialog box closes.</i> |
| 7 | Repeat steps 1 to 5 and create another Observation Point with the following information. |
| 8 | On the General tab: <ul style="list-style-type: none"> In Center, Offset, type/select the following: <ul style="list-style-type: none"> Horizontal: 19 . 5μm Vertical: -4 . 33μm Center depth: 0 . 0 μm Label: Observation Point2 |



- 9 On the **Data Components** tab, ensure that **2D TE: Ey** is selected (default).
- 10 Repeat steps 1 to 5 and create another **Observation Point** with the following information.
- 11 On the **General** tab:
 - In **Center, Offset**, type/select the following:
 - Horizontal: **0.8 μm**
 - Vertical: **0.0 μm**
 - Center depth: **0.0 μm**
 - Label: **Observation Point3**
- 12 On the **Data Components** tab, ensure that **2D TE: Ey** is selected (default).

Note: Observation Point1 and Observation Point2 are used to get the transmittance, while Observation Point3 is for the reflection.

Setting the 2D TE FDTD simulation parameters

- | Step | Action |
|-------------|---|
| 1 | From the Simulation menu, select 2D Simulation Parameters .
<i>The Simulation Parameters dialog box appears.</i> |
| 2 | Type/select the following information: <ul style="list-style-type: none"> Polarization: TE Mesh Delta X [μm]: 0.1 Mesh Delta Y [μm]: 0.1 |
| 3 | Click Advanced... .
<i>The Boundary Conditions dialog box appears.</i> |
| 4 | Type/select the following information: <ul style="list-style-type: none"> -X: Anisotropic PML +X: Anisotropic PML -Z: Anisotropic PML +Z: Anisotropic PML Anisotropic PML Calculation Parameters <ul style="list-style-type: none"> Number of Anisotropic PML Layers: 10 Theoretical Reflection Coefficient: 1.0e-12 Real Anisotropic PML Tensor Parameters: 5.0 Power of Grading Polynomial: 3.5 |
| 5 | In Time Parameters, click Calculate .
<i>The default time step size is calculated.</i> |
| 6 | Select Run for 10000 Time Steps (Results Finalized) . |
| 7 | Select Key Input Information: Input Plane1 and wavelength:1.9 . |



Note: The input plane's center wavelength is used for DFT calculations.

- 8 Click **OK** to close the **Simulation Parameters** dialog box without running the simulation, or click **Run** to start the **OptiFDTD Simulator**.

Note: Before running the simulation, save the project to a file.

Observing the simulation results in OptiFDTD Simulator

Key things to observe:

- Refractive index distribution
- Observe the wave propagation in **OptiFDTD Simulator** (see [Figure 96](#))
- Select **View > Observation Point** to observe the dynamic time domain and frequency domain response (see [Figure 97](#)).

Figure 96 Wave propagation in OptiFDTD Simulator

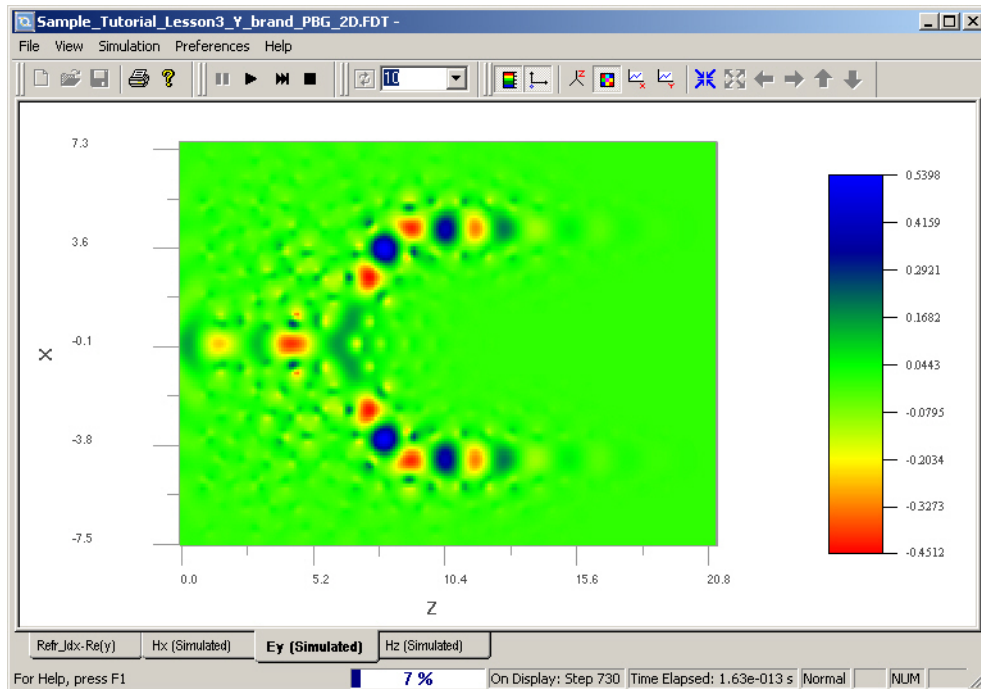
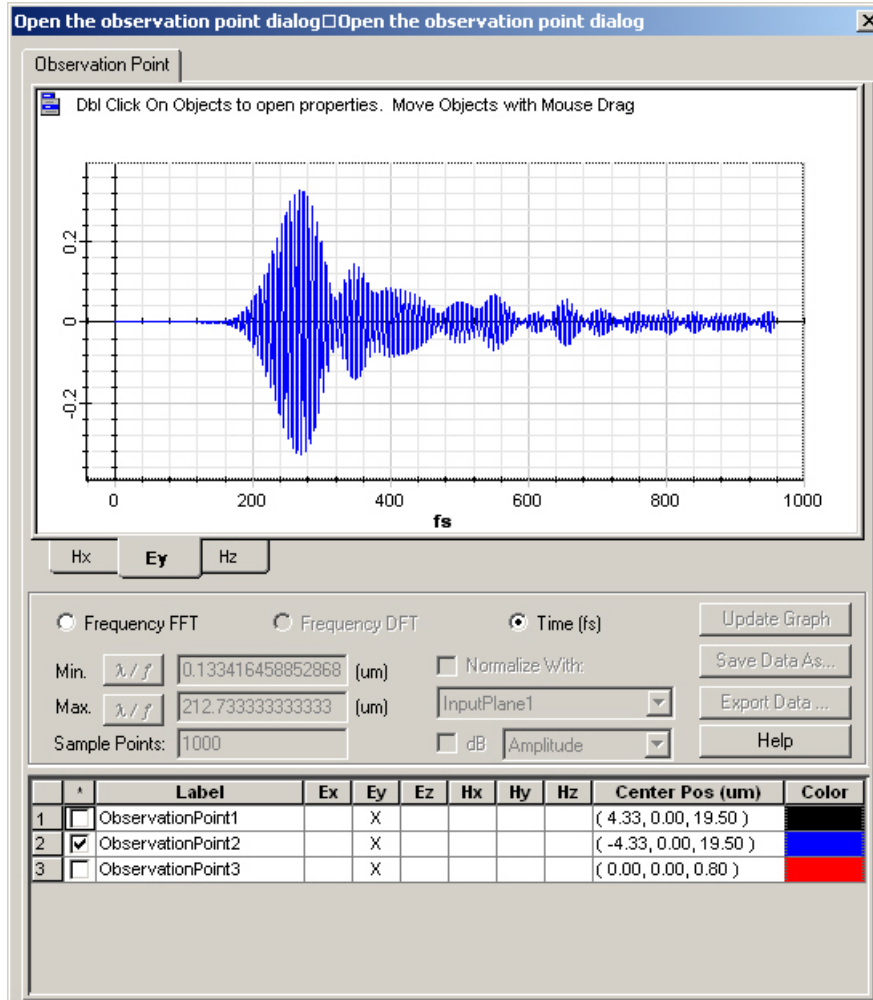


Figure 97 Dynamic time domain and frequency domain response

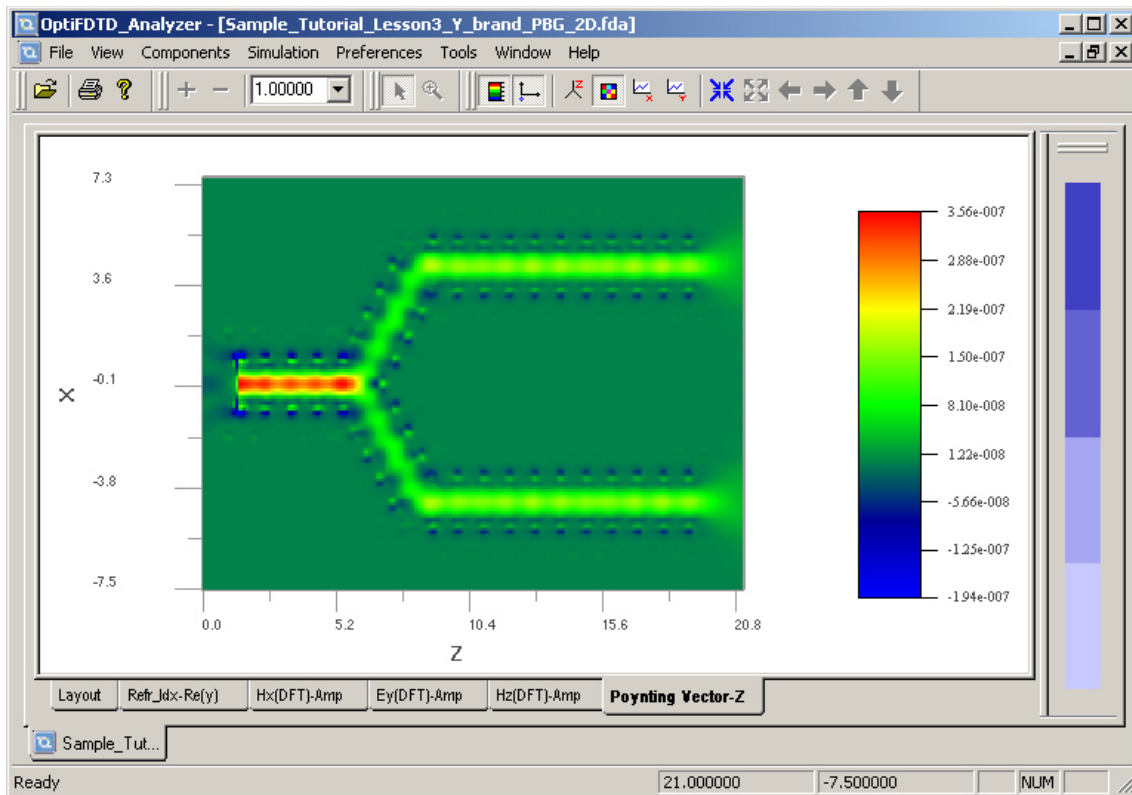


Performing data analysis

In OptiFDTD_Analyzer, you can perform the following analysis for this sample:

- Observe the Layout, Refractive index, Poynting Vector, and field propagation pattern (DFT results) for the center wavelength (see [Figure 98](#) for Poynting Vector-Z).

Figure 98 OptiFDTD Analyzer



- Observe the transmission/reflection calculations

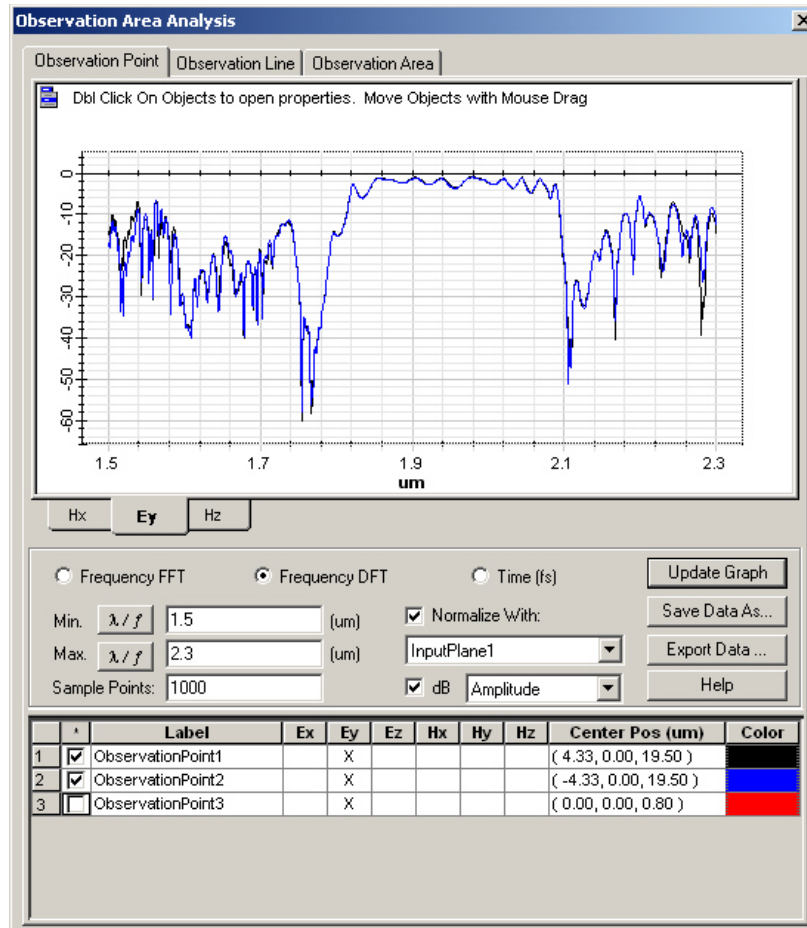
Step Action

- 1 To start the observation point analysis, from the **Tools** menu, select **Observation Area Analysis**.
The Observation Area Analysis dialog box appears (see [Figure 99](#)).
- 2 Select **ObservationPoint1** and **ObservationPoint2**.
The simulation results from the observation points displays in the graph window.
- 3 Type/select the following:
 - Frequency DFT**
 - Min. λ / f : **1.5 μm**
 - Max. λ / f : **2.3 μm**
 - Sample Point: **1000**



Normalize With
 InputPlane1
dB
 Amplitude

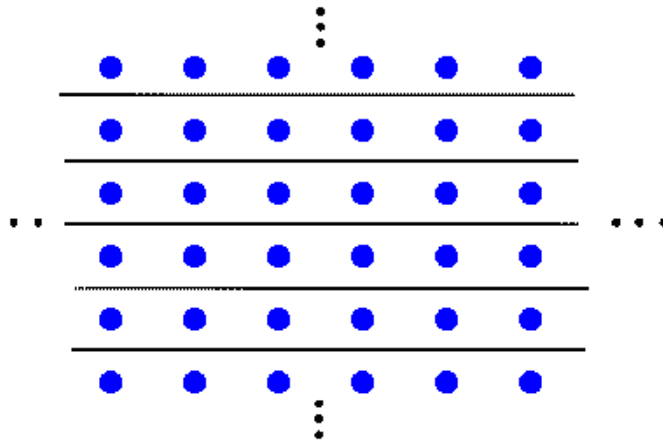
Figure 99 Observation Area Analysis dialog box



Sample 2---Plane wave simulation based on the periodic cell of PhC

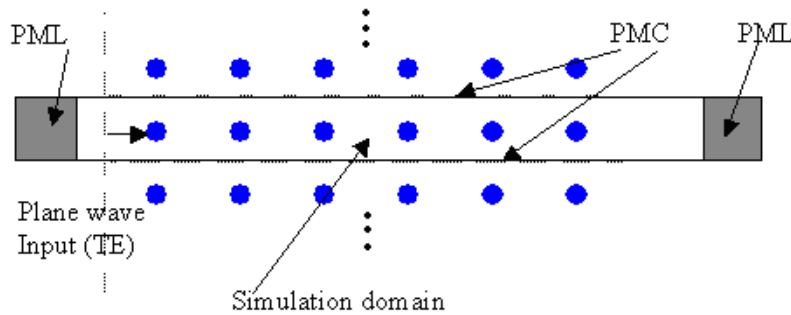
Most of the photonic crystal has the periodic lattice. In some cases, you may want to know the band gap effect for such a lattice. As discussed in the *OptiFDTD Technical Background*, this task can be simplified in an FDTD simulation using plane wave excitation and PEC/PMC boundary conditions. For example, [Figure 100](#) shows a 2D square lattice going to infinity in both x- and z directions.

Figure 100 2D square lattice



You can simulate the structure shown in [Figure 100](#) by taking a domain-reduced region (shown in [Figure 101](#)) with a plane wave and PMC boundary conditions for 2D-TE wave.

Figure 101 Domain reduced region



Designing a PBG structure

To design a PBG structure, perform the following procedures.

- | Step | Action |
|-------------|--|
| 1 | Start Waveguide Layout Designer . |
| 2 | To create a new project, select File > New .
<i>The Initial Properties dialog box appears.</i> |
| 3 | Click Profiles and Materials .
<i>The Profile Designer window appears.</i> |
| 4 | Under the Materials folder of OptiFDTD Designer1, right-click the Dielectric folder and select New .
<i>A new Dielectric material dialog box appears.</i> |
| 5 | Type the following information:
<div style="margin-left: 40px;">Name: PBG_atom</div> <div style="margin-left: 40px;">Refractive index (Re:): 3.1</div> |
| 6 | To save the material, click Store .
<i>PBG_atom appears in the Dielectric folder in the directory and in the dialog box title bar.</i> |

To define the channel profile, perform the following procedure.

- | Step | Action |
|-------------|--|
| 1 | Under the Profiles folder of OptiFDTD Designer1, right-click the Channel folder and select New .
<i>The ChannelPro1 dialog box appears.</i> |
| 2 | Create the following channel profile:
<div style="margin-left: 40px;">Profile name: Profile_PBG</div> <div style="margin-left: 40px;">2D profile definition</div> <div style="margin-left: 80px;">Material: PBG_atom</div> <div style="margin-left: 40px;">3D profile definition</div> <div style="margin-left: 80px;">Layer name: layer_01</div> <div style="margin-left: 80px;">Width: 1.0</div> <div style="margin-left: 80px;">Thickness: 1.0</div> <div style="margin-left: 80px;">Offset: 0.0</div> <div style="margin-left: 80px;">Material: PBG_atom</div> |
| 3 | Click Store . |
| 4 | Close the Profile Designer . |



To define the wafer and waveguide properties, perform the following procedure.

- | Step | Action |
|-------------|---|
| 1 | In the Initial Properties dialog box, type/select the following:
Waveguide Properties
Width [μm]: 1.0
Profile: Profile_PBG
Wafer Dimensions
Length [μm]: 10.0
Width [μm]: 1.0
2D Wafer Properties
Material: Air |
| 2 | Click OK .
<i>The Initial Properties dialog box closes.</i> |
| 3 | In the Layout Designer, from the Draw menu, select PBG Crystal Structure . |
| 4 | In the layout window, drag the cursor from a designated starting point and release, to create the PBG area.
<i>The PBG Crystal Structure appears in the layout window.</i> |
| 5 | To edit the crystal structure, double-click on the PBG structure in the layout.
<i>The Crystal Lattice Properties dialog box appears (see Figure 86 as a reference).</i> |
| 6 | In Origin, Offset , type/select the following:
Horizontal: 2.0
Vertical: -0.5 |
| 7 | Click Evaluate . |
| 8 | Type/select the following:
Depth: 0.0
Azimuth [deg]: 0.0 |
| 9 | In Lattice Properties , select 2D Rectangular . |
| 10 | In Lattice Dimensions , type/select the following:
Scale: 1.0
#A: 1
#C: 6
Note: When a 2D lattice is selected, the Y-direction cell #B is set to the default value of 1. |
| 11 | In Label , type PBGCrystalStruct1 . |

Note: Do **NOT** close the **Crystal Lattice Properties** dialog box.



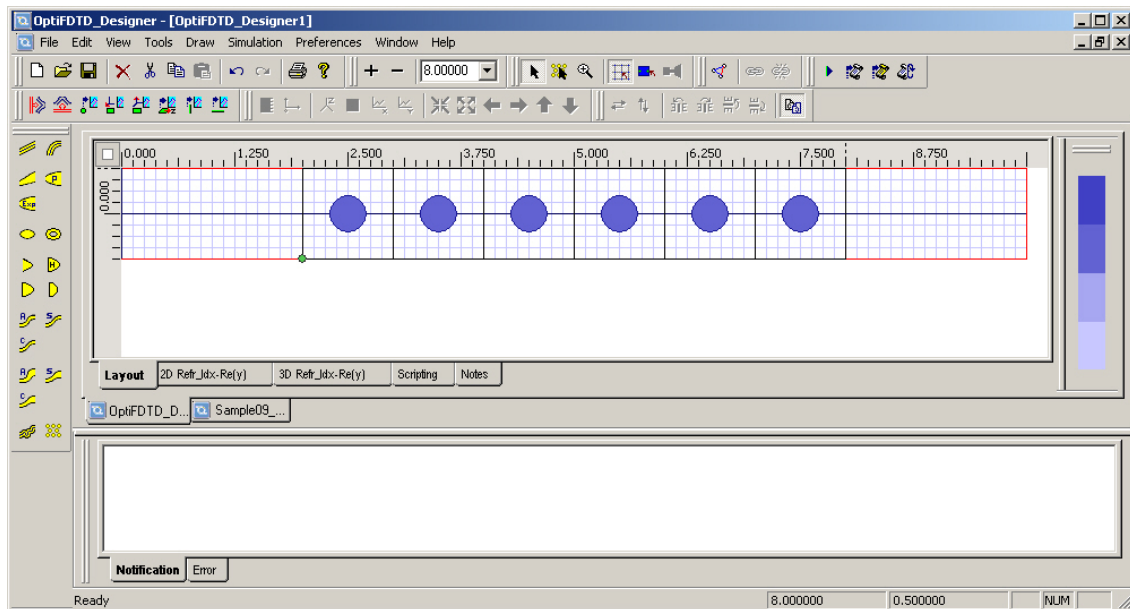
Setting the atom properties

To set the atom properties, perform the following procedure in the **Crystal Lattice Properties** dialog box.

Step Action

- 1 In **Atom Waveguide in Unit Cell, Add New**, select **Elliptic Waveguide** from the drop-down menu and click **New**.
*The **Elliptic Waveguide Properties** dialog box appears (see [Figure 87](#) as a reference).*
- 2 In **Center, Offset**, type/select the following:
Horizontal: 0.5
Vertical: 0.5
- 3 Type/select the following:
Major radius: 0.2
Minor radius: 0.2
Orientation angle: 0.0
Channel thickness tapering: **Use Default (Channel: None)**
Depth: 0.0
Label: **Atom**
Profile: **Profile_PBG**.
- 4 Click **OK** to close the **Elliptic Waveguide Properties** dialog box.
Note: When you return to the **Crystal Lattice Properties** dialog box, you will see the defined elliptic waveguide listed in **Atom Waveguide in Unit Cell**.
- 5 Click **OK** to close the **Crystal Lattice Properties** dialog box.
The defined PBG structure appears in the layout window (see [Figure 102](#)).

Figure 102 Defined PBG structure in layout window



Inserting the input plane

To insert the input plane, perform the following procedure.

- | Step | Action |
|-------------|---|
| 1 | From the Draw menu, select Vertical Input Plane . |
| 2 | To insert the input plane, click in the layout window where you want it placed.
<i>The input plane appears in the layout.</i> |
| 3 | To edit the input plane, double-click on the input plane in the layout.
<i>The Input Plane Properties dialog box appears.</i> |
| 4 | Set Wavelength to 1.9 mm |
| 5 | Select Gaussian Modulated Continuous Wave . |
| 6 | On the Gaussian Modulated CW tab, type/select the following:
Time Offset [Sec]: 6.0e-14
Half Width [Sec]: 1.0e-14 |
| 7 | On the General tab, select Input Field Transverse: Rectangular . |
| 8 | On the 2D Transverse tab, type/select the following:
Center Position [μm]: 0.0
Halfwidth [μm]: 2.0
Tilting Angle [deg]: 0.0
Effective Refractive Index: Local
Amplitude [V/m]: 1.0 |
| 9 | On the General tab, type/select the following:
Plane Geometry
Z Position [μm]: 0.5
Positive direction |
| 10 | Click OK .
<i>The Input Field Properties dialog box closes.</i> |

Setting up the Observation Point

- | Step | Action |
|-------------|--|
| 1 | From the Draw menu, select Observation Point . |
| 2 | Place the Observation Point in the desired position in the layout. |
| 3 | Double-click the observation point.
<i>The Observation Properties -- Point dialog box appears.</i> |
| 4 | On the General tab:
In Center, Offset , type/select the following:
Horizontal: 0.25μm
Vertical: 0.0μm |



- Center depth: 0.0 μm
Label: **Observation Point1**
- 5 On the **Data Components** tab, ensure that **2D TE: Ey** is selected (default).
 - 6 Click **OK**.
*The **Observation Properties -- Point** dialog box closes.*
 - 7 Repeat steps 1 to 5 and create another **Observation Point** with the following information.
 - 8 On the **General** tab:
In **Center, Offset**, type/select the following:
Horizontal: 8.5 μm
Vertical: 0.0 μm
Center depth: 0.0 μm
Label: **Observation Point2**
 - 9 On the **Data Components** tab, ensure that **2D TE: Ey** is selected (default).
 - 10 Repeat steps 1 to 5 and create another **Observation Point** with the following information.
 - 11 On the **General** tab:
In **Center, Offset**, type/select the following:
Horizontal: 9.5 μm
Vertical: 0.0 μm
Center depth: 0.0 μm
Label: **Observation Point3**
 - 12 On the **Data Components** tab, ensure that **2D TE: Ey** is selected (default).

Note: Observation Point1 is used to calculate the reflection, while Observation Point2 and Observation Point3 are used to calculate the transmittance.

Setting the 2D TE FDTD simulation parameters

- | Step | Action |
|-------------|---|
| 1 | From the Simulation menu, select 2D Simulation Parameters .
<i>The Simulation Parameters dialog box appears.</i> |
| 2 | Type/select the following information:
Polarization: TE
Mesh Delta X [μm]: 0.05
Mesh Delta Y [μm]: 0.05 |
| 3 | Click Advanced... .
<i>The Boundary Conditions dialog box appears.</i> |
| 4 | Type/select the following information (see Figure 103): |



-X: **Anisotropic PML**

+X: **Anisotropic PML**

-Z: **Anisotropic PML**

+Z: **Anisotropic PML**

Anisotropic PML Calculation Parameters

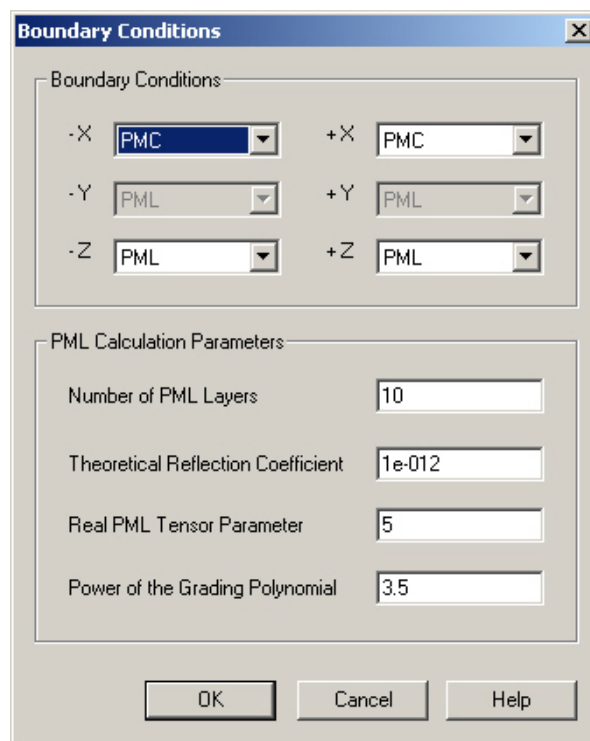
Number of Anisotropic PML Layers: **10**

Theoretical Reflection Coefficient: **1.0e-12**

Real Anisotropic PML Tensor Parameters: **5.0**

Power of Grading Polynomial: **3.5**

Figure 103 2D simulation parameters



Note: The rectangular beam with PMC boundaries on the edge realizes the TE plane wave simulation for the periodic structure.

- 5 In Time Parameters, click **Calculate**.
The default time step size is calculated.
- 6 Select **Run for 12000 Time Steps (Results Finalized)**.
- 7 Select **Key Input Information: Input Plane1 and wavelength:1.9**.

Note: The input plane's center wavelength is used for DFT calculations.

- 8 Click **OK** to close the **Simulation Parameters** dialog box without running the simulation, or click **Run** to start the **OptiFDTD Simulator**.

Note: Before running the simulation, save the project to a file.

Observing the simulation results in OptiFDTD Simulator

Key things to observe:

- Refractive index distribution
- Observe the wave propagation in **OptiFDTD Simulator** (see [Figure 104](#)).
- Select **View > Observation Point** to see the dynamic time domain and frequency domain response (see [Figure 105](#)).

Figure 104 OptiFDTD Simulator—Wave propagation

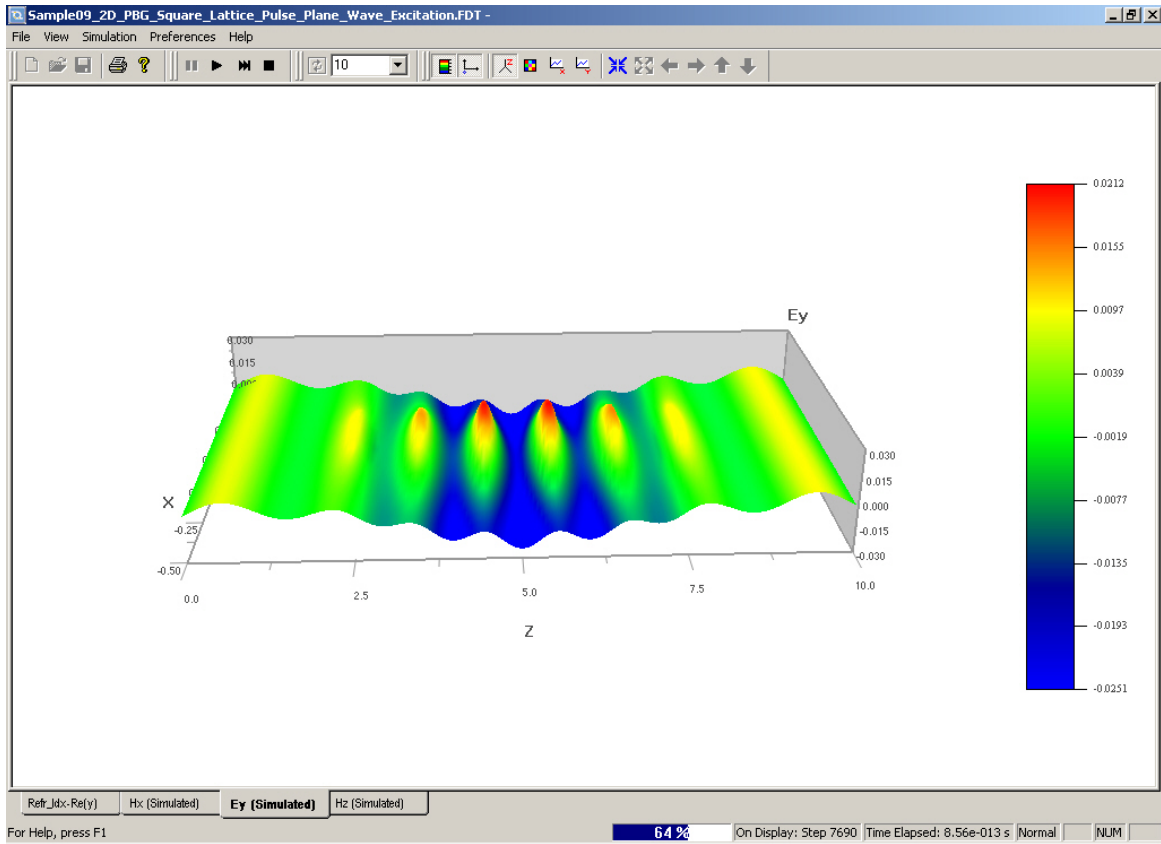
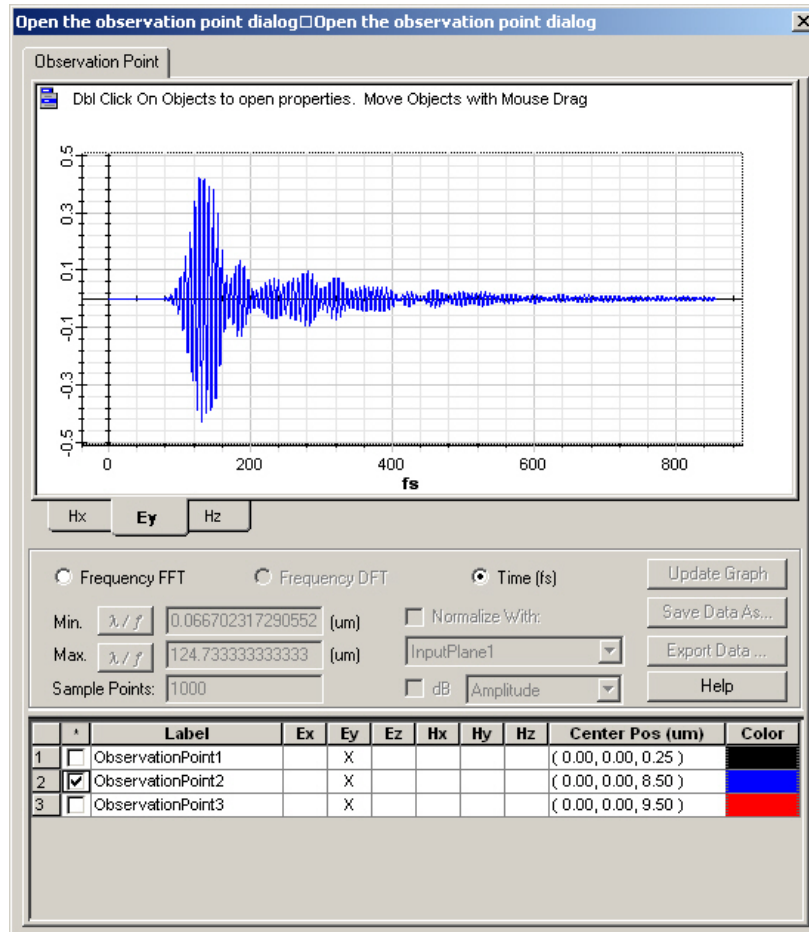


Figure 105 OptiFDTD Simulator—Dynamic time domain and frequency domain response



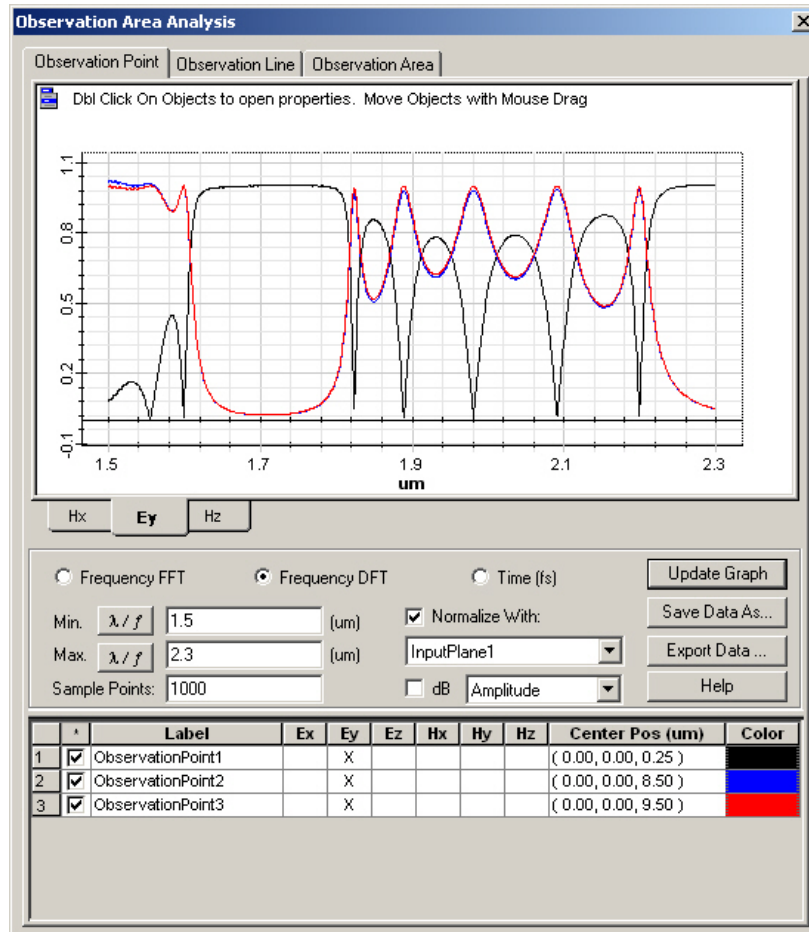
Performing data analysis

In OptiFDTD_Analyzer, perform the following procedure.

- | Step | Action |
|-------------|---|
| 1 | To start the observation point analysis, from the Tools menu, select Observation Area Analysis .
<i>The Observation Area Analysis dialog box appears (see Figure 99).</i> |
| 2 | Select ObservationPoint1 , ObservationPoint2 , and ObservationPoint3 .
<i>The simulation results from the observation points displays in the graph window.</i> |
| 3 | Type/select the following:
<div style="margin-left: 40px;"> <p>Frequency DFT</p> <p>Min. λ / f : 1.5μm</p> <p>Max. λ / f : 2.3μm</p> <p>Sample Point: 1000</p> <p>Normalize With</p> <p style="margin-left: 20px;">InputPlane1</p> </div> |
| 4 | Click Update Graph to view the transmittance and reflection curves (see Figure 106). |



Figure 106 Observation Area Analysis dialog box



Sample 3---Periodic Boundary Condition for PBG simulation

OptiFDTD has options to use simplified **Periodic Boundary Condition (PBC)**. It can work with other boundary conditions such as Anisotropic PML, PMC, and PEC. With PBC, you can simulate a simple plane wave simulation, or a periodic layout simulation.

For more information regarding PBC, see the Technical Background.

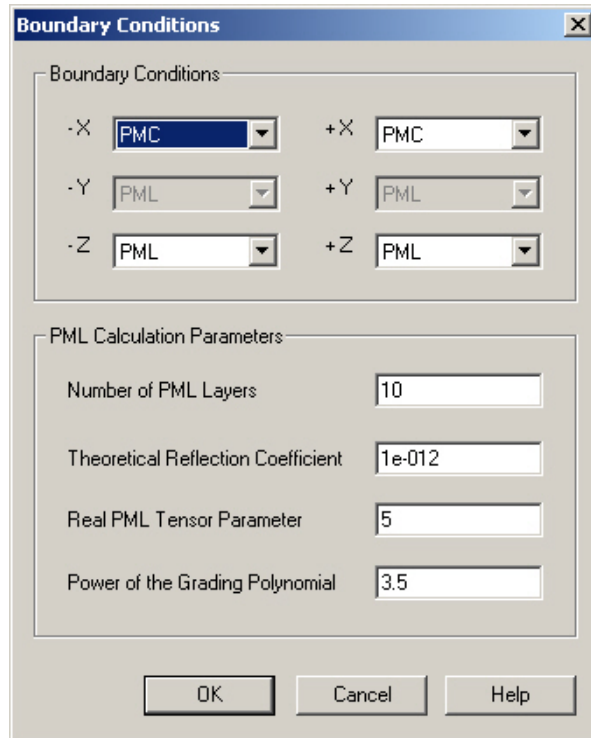
The following procedure is based on . You can also open the project file **Sample09_2D_TE_PBG_Domain_Reduced_Square_Lattice.FDT** that can be found in the **Sample** file folder.

Setting the 2D TE FDTD simulation parameters

- | Step | Action |
|-------------|--|
| 1 | From the Simulation menu, select 2D Simulation Parameters .
<i>The Simulation Parameters dialog box appears.</i> |
| 2 | Type/select the following information:
Polarization: TE
Mesh Delta X [μm]: 0.05
Mesh Delta Y [μm]: 0.05 |
| 3 | Click Advanced...
<i>The Boundary Conditions dialog box appears.</i> |
| 4 | Type/select the following information (see Figure 107):
-X: PMC
+X: PMC
-Z: Anisotropic PML
+Z: Anisotropic PML
Anisotropic PML Calculation Parameters
Number of Anisotropic PML Layers: 10
Theoretical Reflection Coefficient: 1.0e-12
Real Anisotropic PML Tensor Parameters: 5.0
Power of Grading Polynomial: 3.5 |



Figure 107 2D simulation parameters



Note: The rectangular beam with PMC boundaries on the edge realizes the TE plane wave simulation for the periodic structure.

- 5 In Time Parameters, click **Calculate**.
The default time step size is calculated.
- 6 Select **Run for 12000 Time Steps (Results Finalized)**.
- 7 Select **Key Input Information: Input Plane1 and wavelength:1.9**.

Note: The input plane's center wavelength is used for DFT calculations.

- 8 Click **OK** to close the **Simulation Parameters** dialog box without running the simulation, or click **Run** to start the **OptiFDTD Simulator**.

Note: Before running the simulation, save the project to a file.

- 9 Perform the simulation and Post-processing analysis as shown in . You will get the same result as shown in [Figure 104](#).

Lesson 4—Multiple resonant Lorentz dispersive material simulation

Lorentz dispersive material currently can only be simulated in 2D. This lesson describes how to create, run, and analyze a Lorentz dispersive material simulation.

The corresponding layout file is available in the sample folder of OptiFDTD: `sample06_2D_TE_Multi-Lorentz_Dispersion_Multi-Input.FDT`.

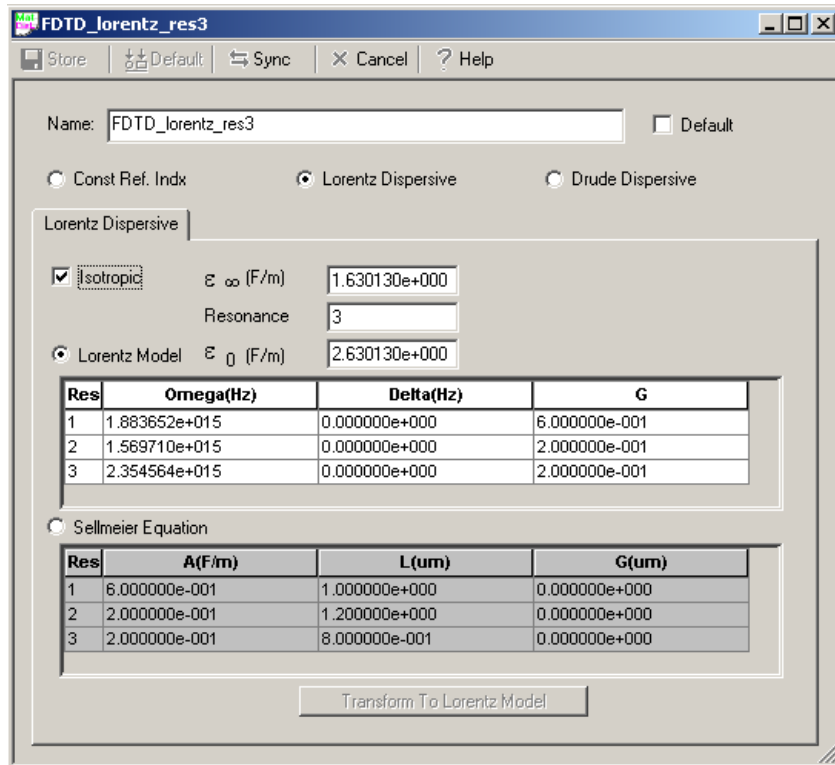
The corresponding results file is available on the OptiFDTD setup CD: `sample06_2D_TE_Multi-Lorentz_Dispersion_Multi-Input.FDA`.

Creating a layout

- | Step | Action |
|------|--|
| 1 | Open Waveguide Layout Designer . |
| 2 | To create a new project, from the File menu, select New .
<i>The Initial Properties dialog box appears.</i> |
| 3 | To open the Profile Designer and set up the material and profile, click Profiles And Materials .
<i>The Profile Designer opens.</i> |
| 4 | In the directory under OptiFDTD_Designer1 , under the Material folder, right-click the FDTD-Dispersive folder.
<i>A context menu appears.</i> |
| 5 | Select New .
<i>The FDTDDielectric1 material definition dialog box appears.</i> |
| 6 | In the FDTDDielectric1 material definition dialog box, click Lorentz Dispersive .
<i>The Lorentz Dispersive dialog box appears (see Figure 1).</i> |



Figure 1 Lorentz Dispersive



- 7 Select **Lorentz Dispersive**, and define the following parameters:
 Name: **FDTD_Lorentz_res3**
 ϵ_{∞} (F/m): **1.630130e00**
 ϵ_0 (F/m): **2.630130e00**
 Resonance number: **3**
- 8 Click **Sellmeier Equation** and input the corresponding values in the **Sellmeier Equation** table shown in [Figure 1](#).
- 9 Click **Transform To Lorentz Model**, then click **Lorentz Model** radio button. *The Lorentz model resonant frequency, damping factor, and strength are shown in [Figure 2](#).*

Figure 2 Frequency, damping factor, and strength

Res	Omega(Hz)	Delta(Hz)	G
1	1.883652e+015	0.000000e+000	6.000000e-001
2	1.569710e+015	0.000000e+000	2.000000e-001
3	2.354564e+015	0.000000e+000	2.000000e-001

- 10 Click **Store** to save the material.



- 11 Repeat Step 4 to design a linear material with refractive index equal to 2.1 and the material with the name **FDTDDielectric2.1**, and click **Store**.
- 12 In the directory under **Profile Designer**, under the **Profile** folder, right-click the **Channel** folder.
A context menu appears.
- 13 Select **New**.
*The **ChannelPro1** dialog box appears.*
- 14 In **ChannelPro1** dialog box, set the Profile Name as **Lorentz_res3** and the 2D profile material as **FDTD_Lorentz_res3**.
- 15 Save the profile.
- 16 Repeat Steps 12 to 14 design another 2D channel profile with the name **Linear2.1** and the material as **FDTDDielectric2.1**.
- 17 Click **Store** to save the defined profile.
- 18 Close the **Profile Designer**.
- 19 In the **Initial Properties** dialog box, set the following parameters:
 - Waveguide Properties**
 - Width: 1 . 0
 - Profile: **Lorentz_res3**
 - Wafer dimension**
 - Length: 10
 - Width: 8
 - 2D Wafer Material: **Air**
- 20 Click **OK** to start the layout designer.
The Designer window appears.
- 21 In the **Waveguide Layout Designer** window, from the **Draw** menu, select **Linear Waveguide**.
- 22 Draw the waveguide in the layout at the desired position.
The waveguide appears in the layout.
- 23 To edit the waveguide position and properties, double-click the waveguide in the layout.
*The **Linear Waveguide Properties** dialog box appears.*



24 Type the following parameters:

Waveguide start position

Horizontal: 0

Vertical: 2

Waveguide end position

Horizontal: 10

Vertical: 2

Select the **Use Default** checkbox.

Width: 1.0

Depth: 0

Profile: **Linear2.1**

25 Repeat Steps 21 to 23 design another linear waveguide with following properties:

Waveguide start position

Horizontal: 0

Vertical: -2

Waveguide end position

Horizontal: 10

Vertical: -2

Select the **Use Default** checkbox.

Width: 1.0

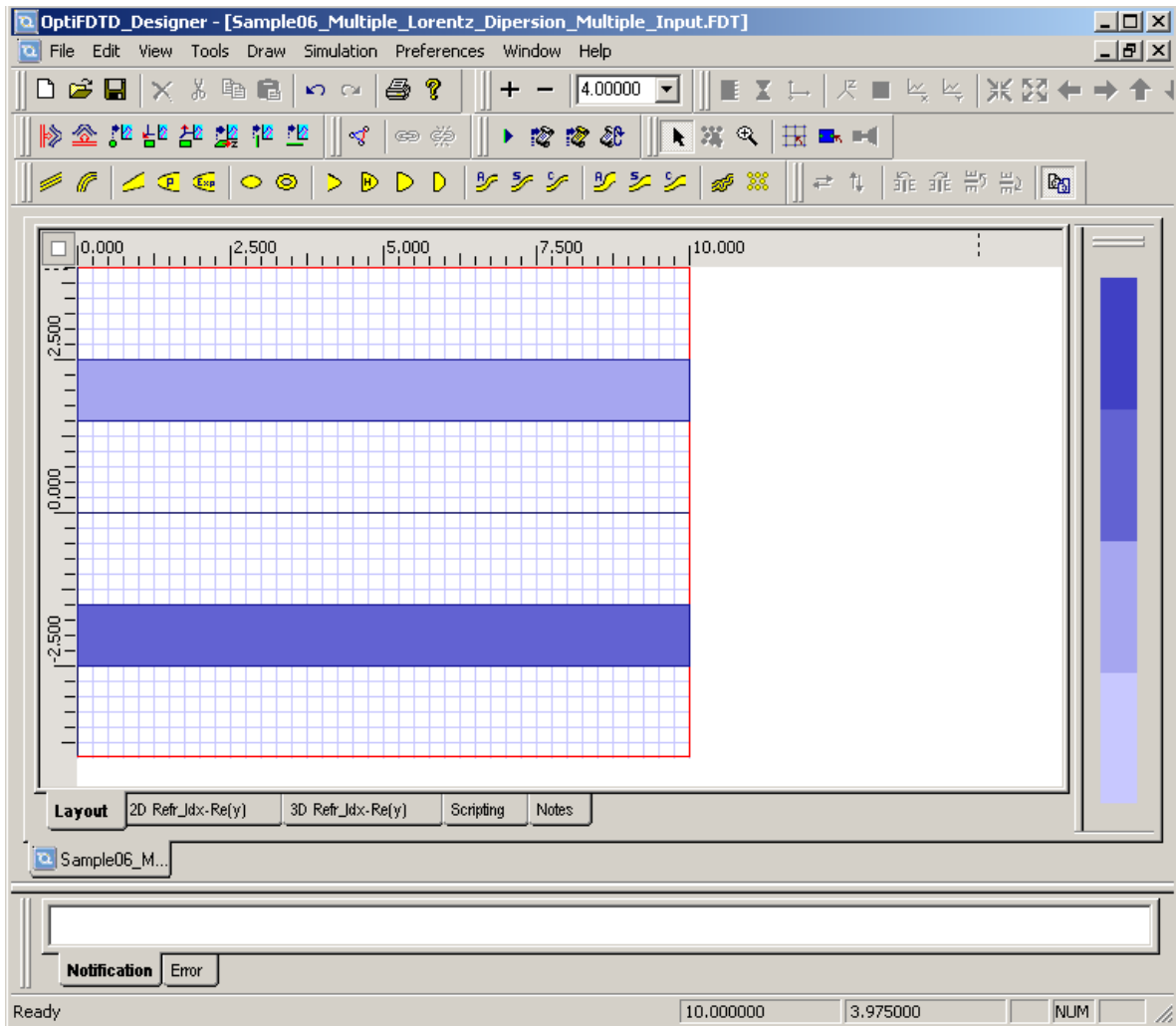
Depth: 0

Profile: **Lorentz_res3**

*The two waveguides appear in the layout. The upper one is the **Linear** waveguide, and the lower one is the **Lorentz Dispersive** waveguide (see [Figure 3](#)).*



Figure 3 Linear and Lorentz Dispersive waveguides



Setting the Input Plane

- | Step | Action |
|------|--|
| 1 | From the Draw menu, select Vertical Input Plane . |
| 2 | Click in the layout to place the Input Plane in the desired position.
<i>A red line that presents the input plane appears in the layout window.</i> |
| 3 | To edit the Input Plane properties, in the layout, double-click the Input Plane.
<i>The Input Field Properties dialog box appears.</i> |

- 4 Click **Gaussian Modulated Continuous Wave**.
- 5 Set the center wavelength to **1.35 μm**
- 6 To edit the Input Pulse, click the **Gaussian Modulated CW** tab.
- 7 Type the following values:
 - Time offset (sec): **4.0e-14**
 - Half width (sec): **1.5e-14**
- 8 Click the **General** tab, and then click **Modal**.
- 9 Click the **2D Transverse** tab to start solving the 2D TE fundamental mode for the lower waveguide, and then apply the solved mode as the input plane.
- 10 Repeat Steps 1-8 to design another vertical input plane in the same position as Input Plane1, and set the Mode input for the upper waveguide.

Setting up the Observation point

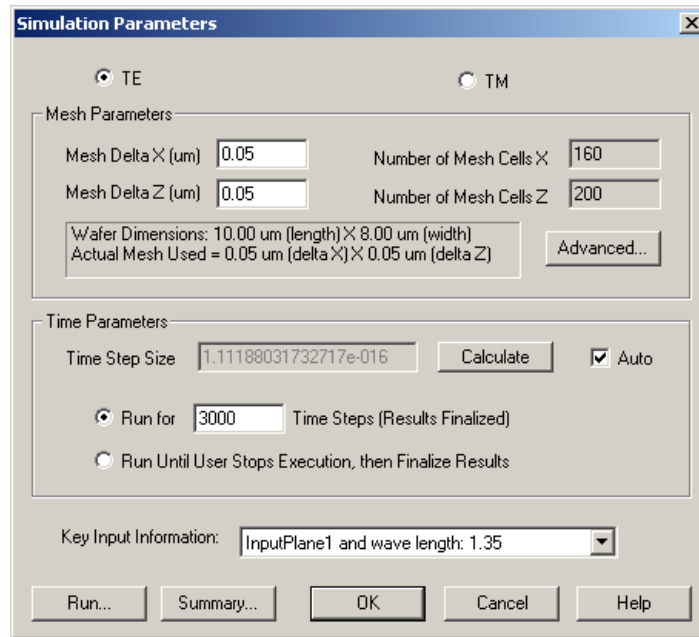
- | Step | Action |
|-------------|--|
| 1 | From the Draw menu, select Observation Point . |
| 2 | Click in the layout to place the observation point in the desired position. |
| 3 | To edit the observation point properties, double-click the observation point in the layout.
<i>The Observation Point Properties dialog box appears.</i> |
| 4 | Type the following values: <ul style="list-style-type: none"> Center Position <ul style="list-style-type: none"> Horizontal: 7.5μm Vertical: -2 Depth: 0 Data Components <ul style="list-style-type: none"> 2D TE: Ey (default) |
| 5 | Repeat Steps 1 to 4 to design another observation point with the following values: <ul style="list-style-type: none"> Center Position <ul style="list-style-type: none"> Horizontal: 7.5μm Vertical: 2 Depth: 0 Data Components <ul style="list-style-type: none"> 2D TE: Ey (default) |



Setting up the 2D simulation parameters

- Step Action**
- From the **Simulation** menu, select **2D Simulation Parameters**.
The **Simulation Parameters** dialog box appears (see [Figure 4](#)).

Figure 4 Simulation Parameters dialog box



- Click **TE**.
- Type the following Mesh Delta X and Mesh Delta Z values: **0.05**
- To set the Anisotropic PML boundary condition parameters, click **Advance**.
The **Boundary Conditions** dialog box appears.
- Type the following values:
 - Number of Anisotropic PML layer: **10**
 - Theoretical Reflection Coefficient: **1.0e-12**
 - Real Anisotropic PML Tensor Parameter: **5.0**
 - Power of Grading Polynomial: **3.5**
- Click **OK**.
- Click **Calculate** for time step size.
- In the **Run for Time Steps (Results Finalized)** field, type **3000**.



- 9 From the **Key Input Plane** drop-down list, select **Input Plane1** and **wavelength:1.35**

Note: The Key Input Plane center wavelength is used for the DFT calculation.

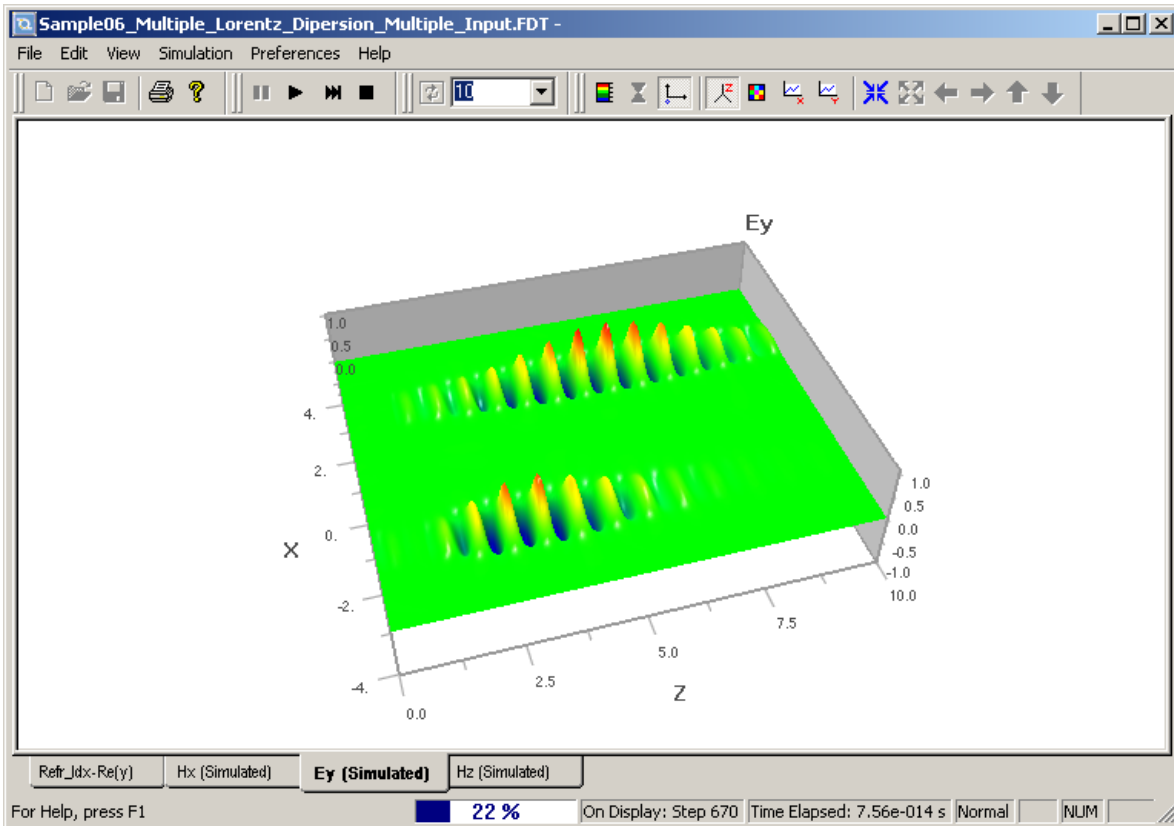
- 10 To save the settings and start the 2D simulation, click **Run**.
- 11 After the simulation ends, open OptiFDTD_Analyzer.

Performing the simulation

Step Action

- 1 In **OptiFDTD_Simulator**, view the refractive index distribution and the wave propagation (see [Figure 5](#)).

Figure 5 View simulation results in OptiFDTD_Analyzer



Note:

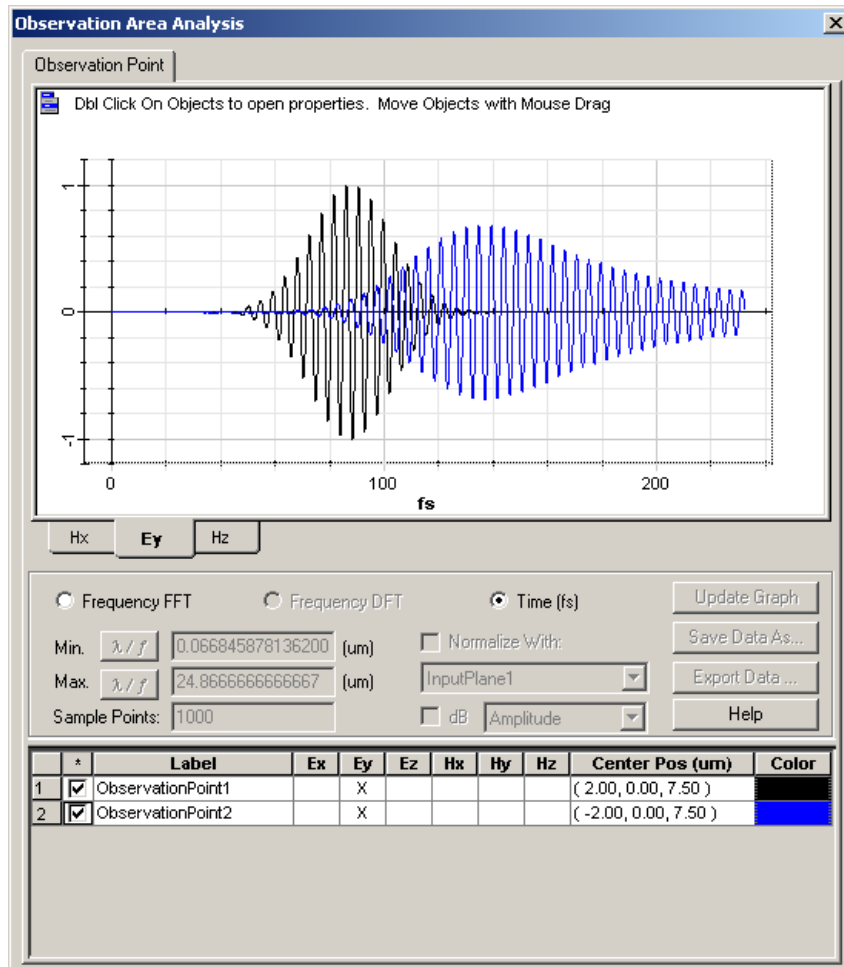
- The two input waves have the same parameters.
- The wave in the Dispersive waveguide is delayed because of the Dispersive effect.



- 2 To view the dynamic time domain and frequency domain response, from the **View** menu in the **OptiFDTD_Simulator**, select **Observation Point Analysis**.

The **Observation Area Analysis** dialog box opens (see [Figure 6](#)).

Figure 6 Observation Area Analysis dialog box



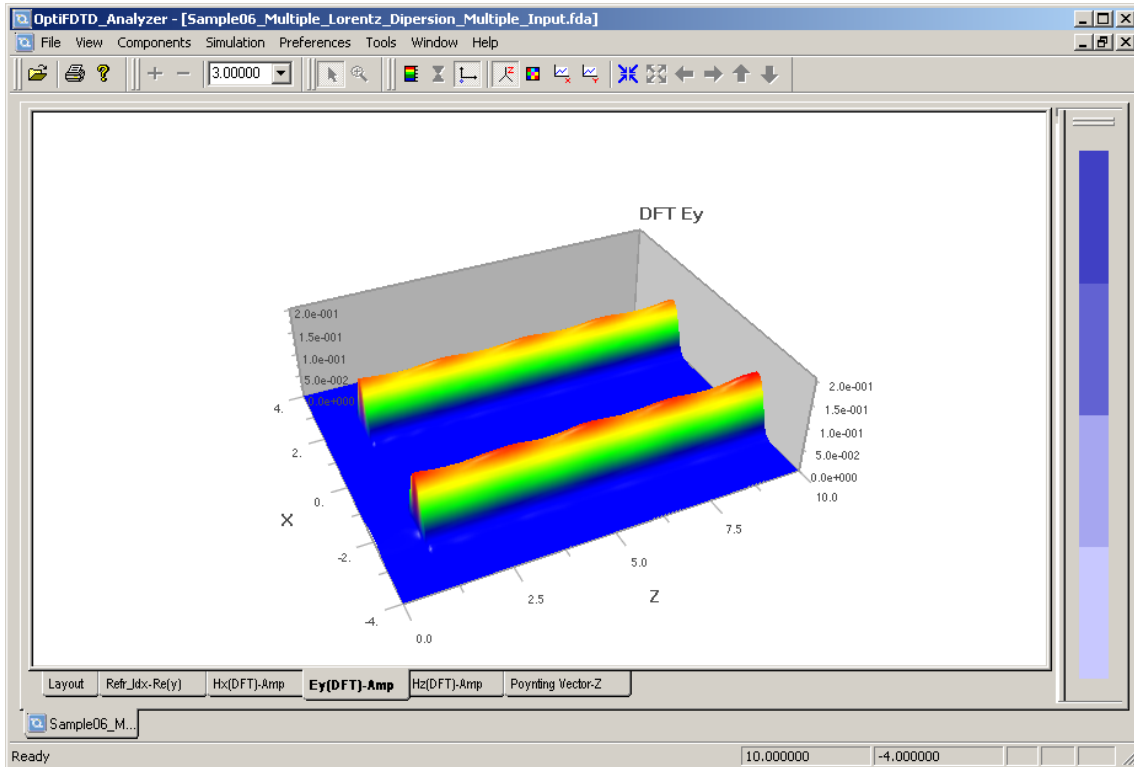
Performing data analysis

Using this example, you can perform the following analysis in OptiFDTD_Analyzer.

Step Action

- 1 View the layout, refractive index, Poynting vector, and field propagation pattern (DFT results) for the center wavelength (see [Figure 7](#)).

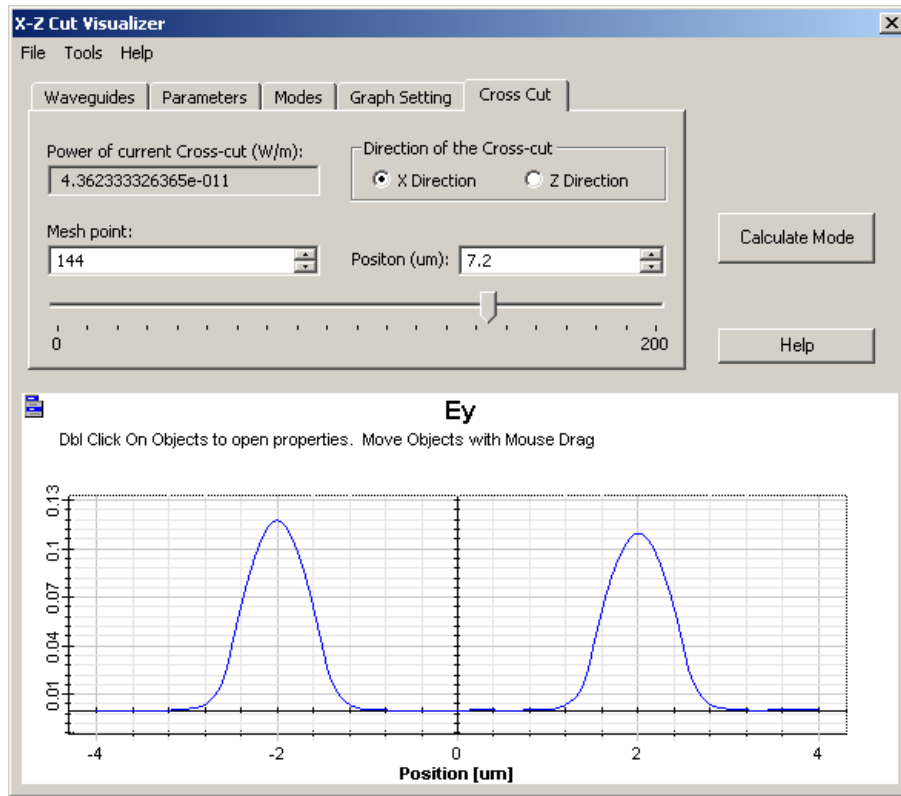
Figure 7 View simulation results for the center wavelength



- 2 To view the Mode Analysis, from the **Tools** menu, select **Crosscut Viewer**. The **X-Z Cut Visualizer** dialog box appears (see [Figure 8](#)).

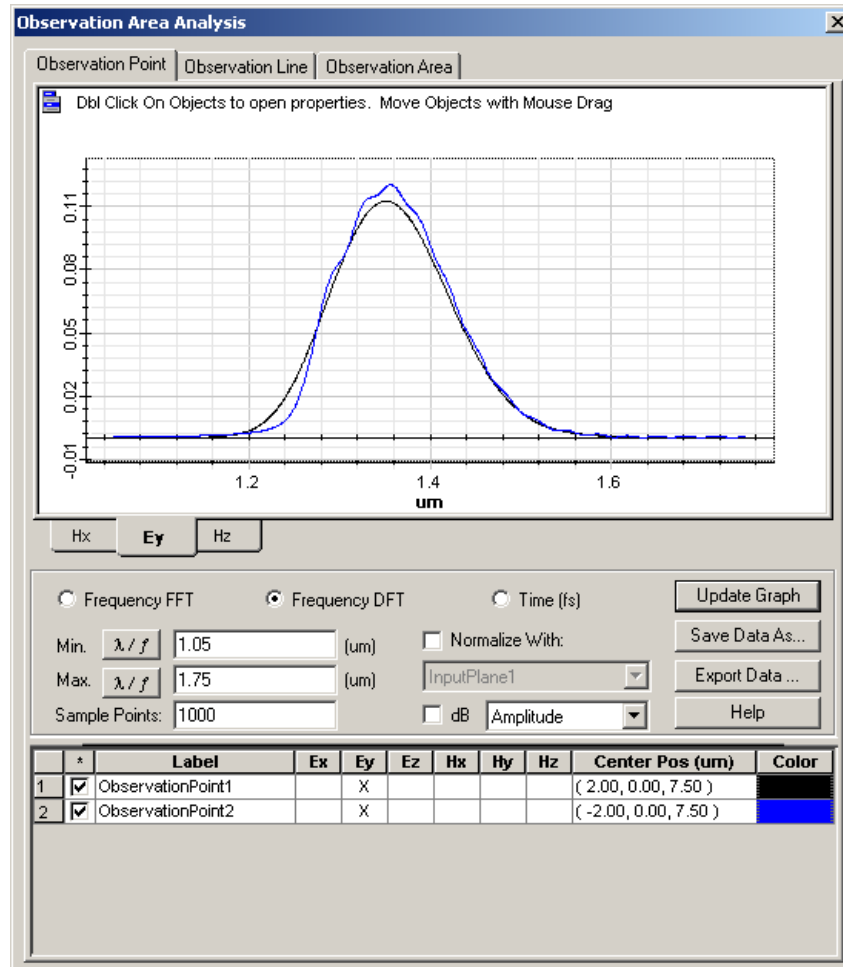


Figure 8 X-Z Cut Visualizer dialog box



- 3 To start the observation point analysis, from the **Tools** menu, select **Observation Area Analysis**.
The *Observation Area Analysis dialog box* opens (see [Figure 9](#)).

Figure 9 Observation Area Analysis dialog box



Lesson 5—Drude model for noble metal and surface plasma simulation

OptiFDTD provides two types of Dispersive material simulations:

- Multiple Resonant Lorentz
- Drude

The Drude model is supposed to be used for the Noble Metal and Surface Plasma in optical band.

Note: It is recommended that you read the section in the Technical Background describing the Drude model equation. OptiFDTD also provides a sample for a Drude model simulation. The following explanation uses this sample file as an example.

The corresponding layout file is available in the sample folder of OptiFDTD:
Sample15_2D_TE_Drude_Model_Emitting_Diode.FDT.

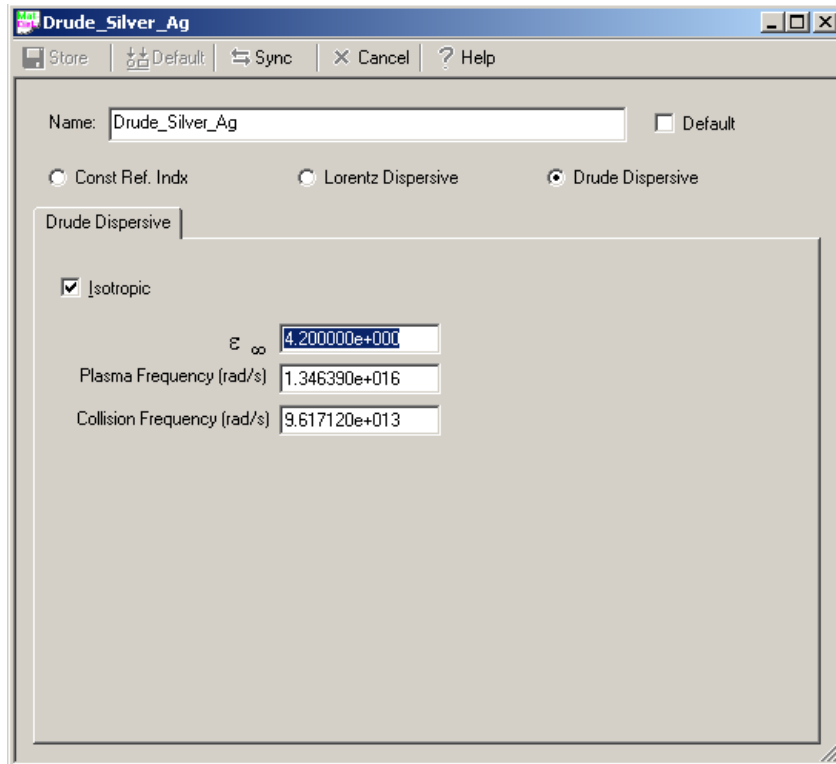
The corresponding results file is available on the OptiFDTD setup CD:
Sample15_2D_TE_Drude_Model_Emitting_Diode.FDA.

Creating a project with Drude material

- | Step | Action |
|-------------|--|
| 1 | Start Waveguide Layout Designer . |
| 2 | To create a new project, from the File menu, select New .
<i>The Initial Properties dialog box appears.</i> |
| 3 | Click the Profiles And Materials .
<i>The Profile Designer appears.</i> |
| 4 | In the directory under OptiFDTD_Designer1 of the Profile Designer, under the Materials folder, right-click the FDTD-Dispersive folder, and select New .
<i>The FDTDDielectric1 material definition dialog box appears.</i> |
| 5 | In the FDTD Dielectric1 material definition dialog box, select Drude Dispersive .
<i>The Dispersive Material Definition dialog box appears (see Figure 1).</i> |



Figure 1 Dispersive Material Definition dialog box



- 6 In the **Drude Material Definition** dialog box, define the following parameters:
 Name: **Drude_Silver_Ag**
 ϵ_{∞} (F/m): **1.999**
 Plasma Frequency: **1.346390e+016**
 Collision Frequency: **9.617120e+013**
- 7 Click **Store** to save the material.
- 8 In the directory under **OptiFDTD_Designer1** of the Profile Designer, under the **Materials** folder, right-click the **Dielectric** folder, and select **New**.
*The **Dielectric1** material definition dialog box appears.*
- 9 Design a linear material with refractive index equal to **1.414** and Material name **Dielectricn=1.414**.
- 10 Click **Store**.
- 11 In the directory under **OptiFDTD_Designer1**, Profile folder, right-click the **Channel** folder, and select **New**.
*The **ChannelPro1** dialog box appears.*



- 12 In the **ChannelPro1** dialog box, set Profile Name to **Ag** and 2D Profile Material to **Drude_Silver_Ag**.
- 13 Save the profile.
- 14 Design another 2D channel profile with the name **Core** and material **Dielectricn=1.414**.
- 15 Click **Store**.
- 16 Close the **Profile Designer**.

Designing the waveguides

- | Step | Action |
|-------------|--|
| 1 | <p>In the Initial Properties dialog box, set the following parameters:</p> <p style="padding-left: 20px;">Waveguide Properties</p> <p style="padding-left: 40px;">Width: 0.12μm</p> <p style="padding-left: 40px;">Profile: Core</p> <p style="padding-left: 20px;">Wafer dimension</p> <p style="padding-left: 40px;">Length: 1.8μm</p> <p style="padding-left: 40px;">Width: 1.4μm</p> <p style="padding-left: 20px;">2D Wafer Material: Air</p> |
| 2 | <p>Click OK to start the Layout Designer.
<i>The OptiFDTD designer window appears.</i></p> |
| 3 | <p>From the Draw menu, select Linear Waveguide.</p> |
| 4 | <p>Draw the waveguide in the layout at desired the position.
<i>The waveguide appears in the layout.</i></p> <p>Note: Click the Select tool after drawing the waveguide.</p> |
| 5 | <p>Double click the waveguide to edit the waveguide position and properties.
<i>The Linear Waveguide properties dialog box appears.</i></p> |
| 6 | <p>Set the following parameters:</p> <p style="padding-left: 20px;">Waveguide start position</p> <p style="padding-left: 40px;">Horizontal: 0</p> <p style="padding-left: 40px;">Vertical: 0</p> <p style="padding-left: 20px;">Waveguide end position</p> <p style="padding-left: 40px;">Horizontal: 1.8</p> <p style="padding-left: 40px;">Vertical: 0</p> <p style="padding-left: 20px;">Select Use Default checkbox.</p> <p style="padding-left: 20px;">Width: 0.12</p> <p style="padding-left: 20px;">Depth: 0.0</p> <p style="padding-left: 20px;">Profile: Core</p> |



7 Design another linear waveguide with following properties:

Waveguide start position

Horizontal: 0

Vertical: -0.24

Waveguide end position

Horizontal: 1.8

Vertical: -0.24

Select **Use Default** checkbox.

Start thickness: 1.0

End thickness: 1.0

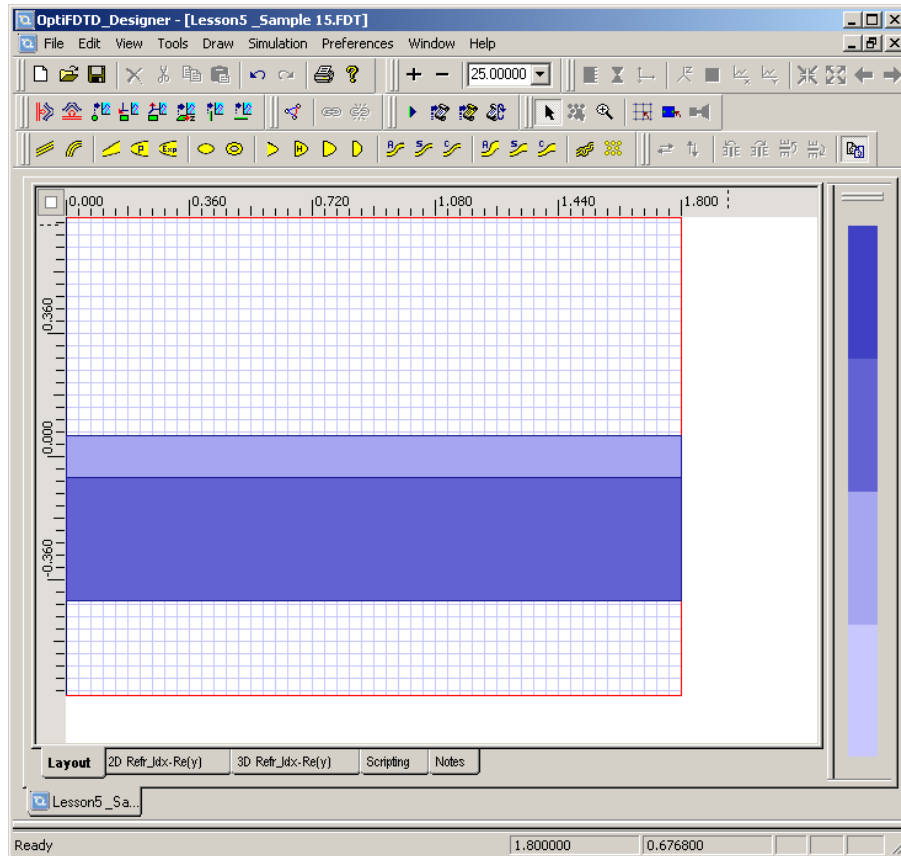
Width: 0.36

Depth: 0.0

Profile: **Ag**

The two waveguides appear in the layout, the upper one is the linear waveguide, which will guide the wave, and the lower one is the Substrate Silver layer in the emitting diode (see [Figure 2](#)).

Figure 2 Waveguides in the layout



To enhance the Light Fitting, a corrugated surface plasma is deposited in the core. To do this, periodic rectangular linear waveguides are designed following the waveguide design outline in the previous procedure.

Each of the rectangular linear waveguides that make up the corrugated surface plasma has the following common parameters (see [Figure 3](#)):

Width: $0.02\mu\text{m}$

Depth: $0.0\mu\text{m}$

Select **Use Default** checkbox.

Note: Thickness is only used for 3D layout definitions.

Profile: **Ag**

Start vertical: $0.05\mu\text{m}$

End vertical: $0.05\mu\text{m}$

The six **Start/End** horizontal positions are:

i. $0.4\mu\text{m}/0.5\mu\text{m}$

ii. $0.6\mu\text{m}/0.7\mu\text{m}$

iii. $0.8\mu\text{m}/0.9\mu\text{m}$

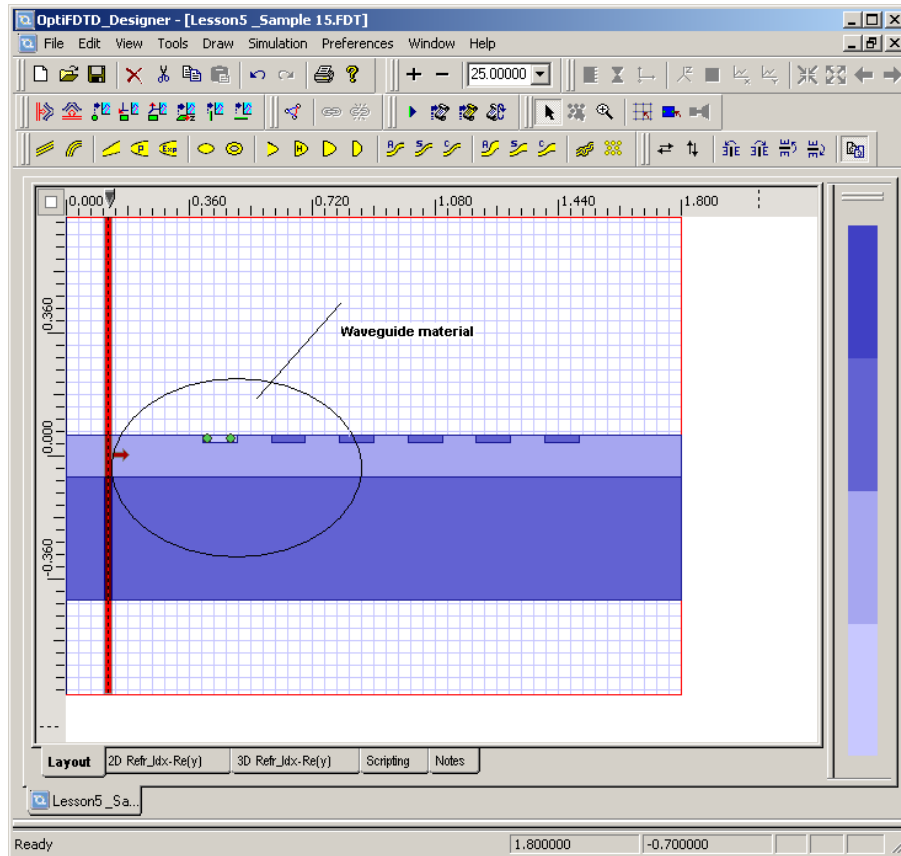
iv. $1.0\mu\text{m}/1.1\mu\text{m}$

v. $1.2\mu\text{m}/1.3\mu\text{m}$

vi. $1.4\mu\text{m}/1.5\mu\text{m}$



Figure 3 Waveguide materials



Setting the Input Plane

- | Step | Action |
|------|---|
| 1 | From the Draw menu, select Vertical Input Plane . |
| 2 | Insert the Input Plane into the layout at the desired position.
<i>A red line representing the input plane appears in the layout window.</i> |
| 3 | Double-click the Input Plane.
<i>The Input Field Properties dialog box appears.</i> |
| 4 | Select Continuous Wave . |
| 5 | Set the center wavelength to 0.4 μm . |
| 6 | Click the General tab, and then click Modal . |
| 7 | Click the 2D Transverse tab to start solving the 2D TE fundamental mode for the Core (Waveguide Linear1) waveguide. |
| 8 | Click Calculate Mode button. |
| 9 | On the Modes tab, select Solved Mode . |
| 10 | Click Apply Data . |

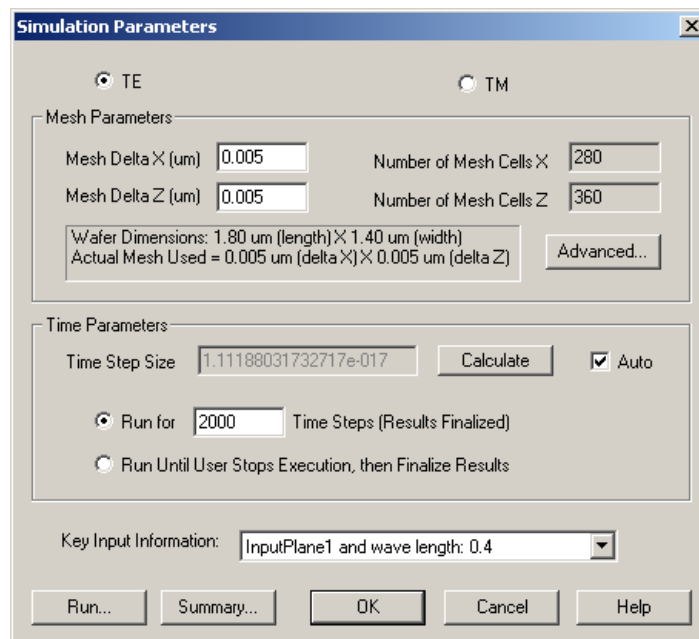


- 11 Return to the **Input Field Properties** dialog box and click **General** tab.
- 12 Set **Plane Geometry Position** to **0 . 125**.
- 13 Select **Positive direction**.
- 14 Click **OK**.

Setting up 2D Simulation parameters

- | Step | Action |
|------|---|
| 1 | From the Simulation menu, select 2D Simulation Parameters .
The Simulation Parameters dialog box appears (see Figure 4). |

Figure 4 Simulation Parameters dialog box



- 2 Click **TE**.
- 3 Set x-direction mesh and z-direction mesh to **0 . 005**.
- 4 Click **Advanced**.
- 5 Set the Anisotropic PML boundary condition parameters:
 - Number of Anisotropic PML layer: **14**
 - Theoretical Reflection Coefficient: **1 . 0e-12**
 - Real Anisotropic PML Tensor Parameter: **1 . 0**
 - Power of Grading Polynomial: **3 . 5**

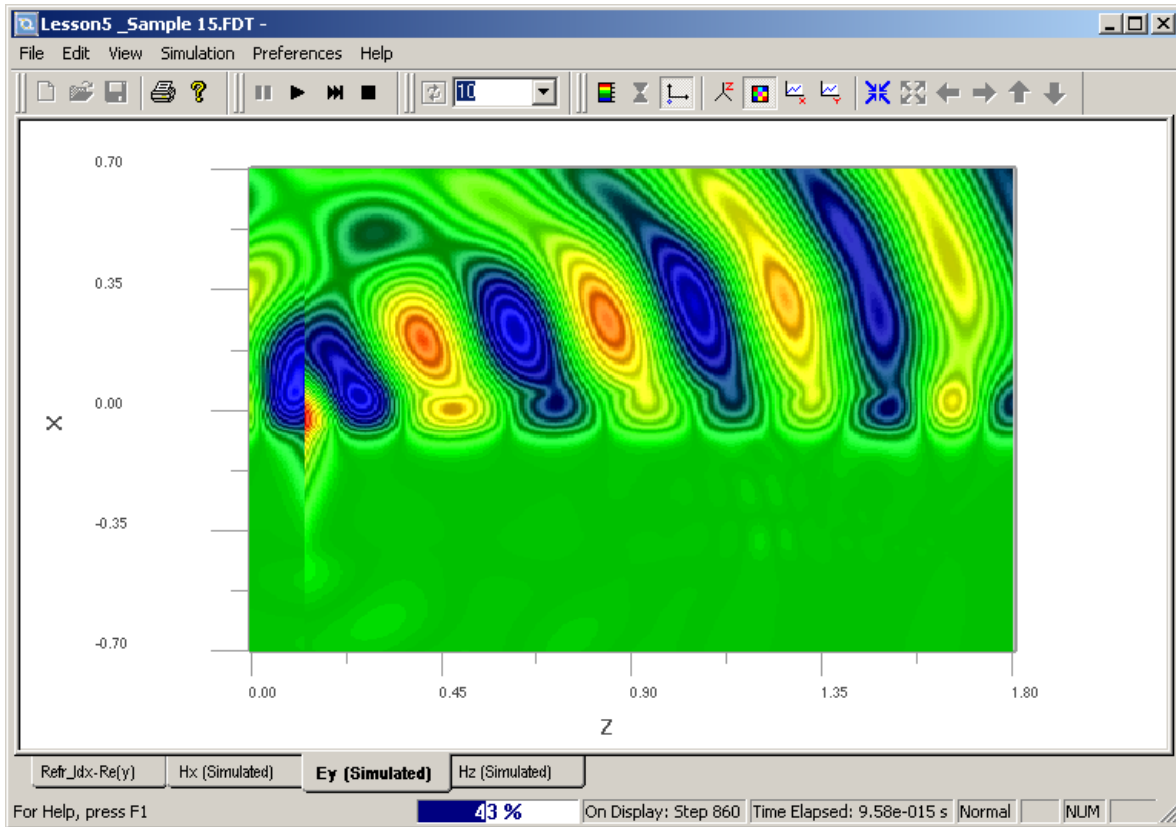
- 6 Click **Calculate** to get the Time Step Size.
- 7 Set **Run** for 2000 time steps for finalization.
- 8 From the **Key Input Plane** drop-down list, select **Input Plane1** and **Wavelength to 0.4**.
Note: The Key Input Plane's Center Wavelength will be used for the DFT calculation.
- 9 Click **OK** to close the **Simulation Parameters** dialog box without running the simulation, or click **Run** to start the **OptiFDTD Simulator**.

Performing the simulation

When the Simulator starts, the emitting field can be observed (see [Figure 5](#)).

Note: Please use the **Rainbow_Banded Palette** to view the graph. Right-click on the graph to set the graph control.

Figure 5 OptiFDTD_Simulator

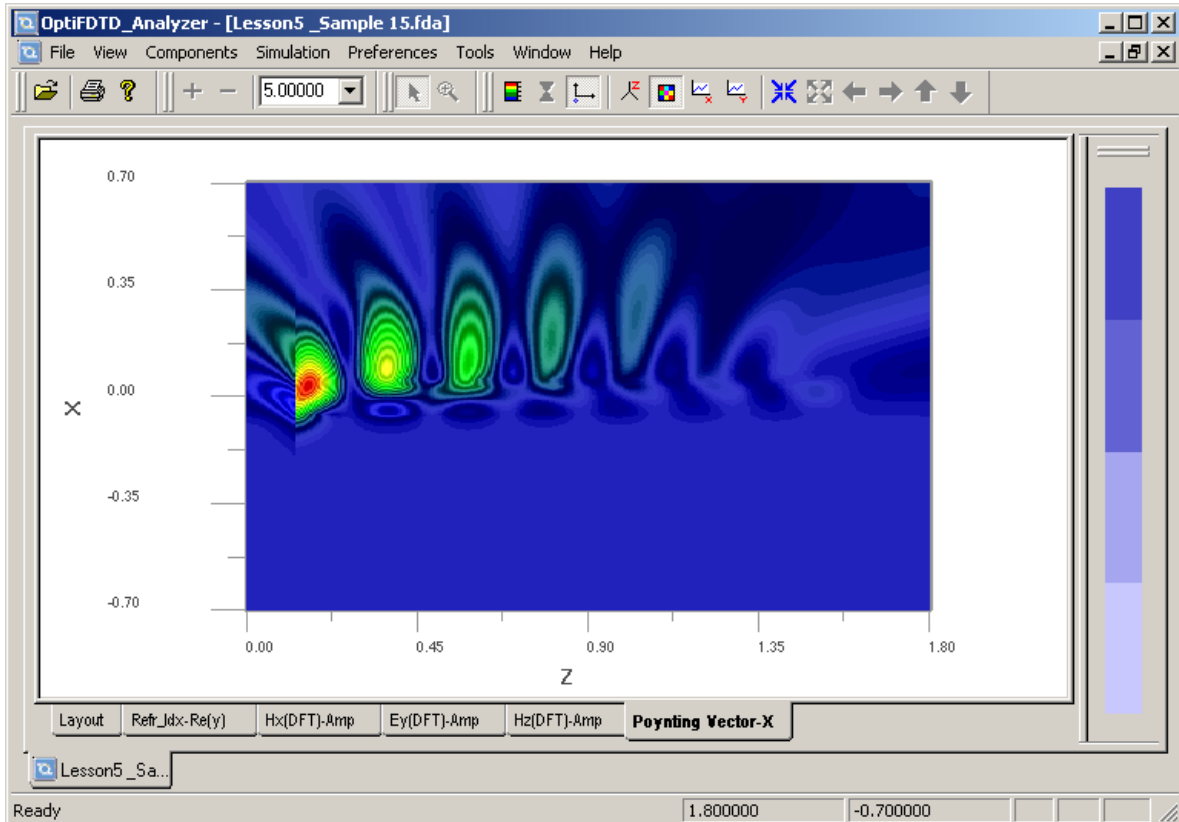


Performing data analysis

With the example used in this lesson, in the **Analyzer** you can perform the following analysis:

- Observe the **Layout, Refractive Index Poynting Vector**, field propagation pattern (DFT results) for the **Input Wavelength** (see [Figure 6](#)).

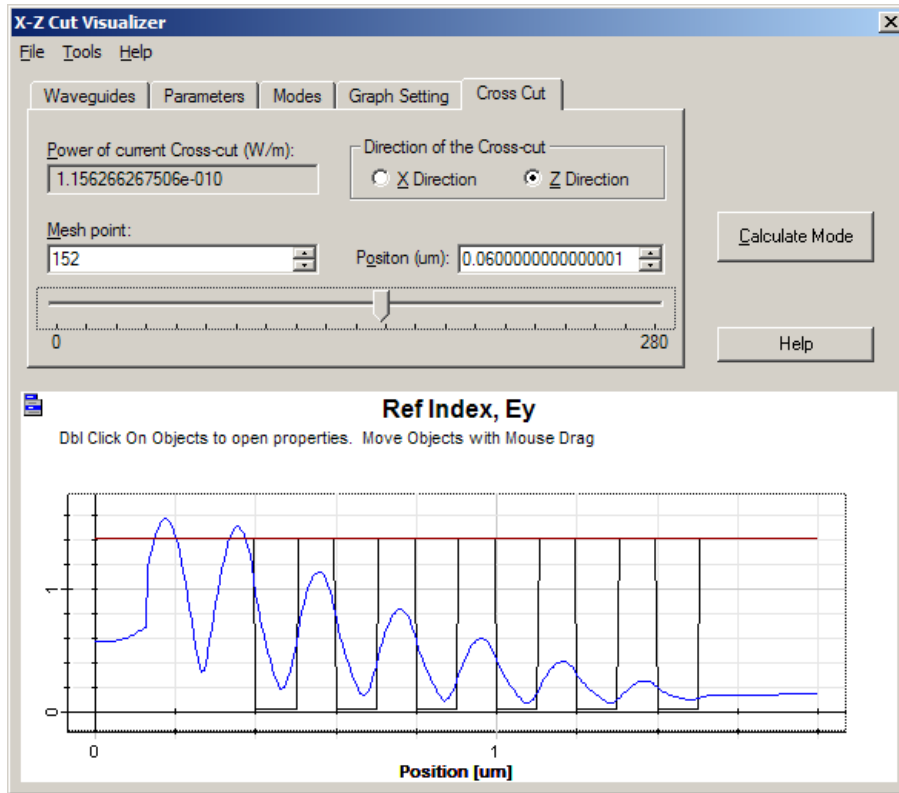
Figure 6 X-direction Poynting Vector



- Select the **Cross Cut** in the **Tools** menu to get the Mode Analysis, slice power, and far field transformation. The X-Z Slice viewer appears (see [Figure 7](#)).



Figure 7 X-Z Slice viewer



Lesson 6—2nd-Order nonlinearity simulation

OptiFDTD provides four types of nonlinear materials.

- 2nd Order
- 3rd Order
- Kerr-effect
- Raman-effect

All of these nonlinearities can be combined with the Lorentz dispersive model, which leads to dispersive nonlinear properties. To simulate the nonlinear material correctly, we recommend that you read the [FDTD Basics](#).

Note:

- Because the nonlinear material may have a high frequency response, a finer mesh size for the simulation may be required.
- Set a suitable power level in the input plane. If the input power is too low, the material may not be excited to nonlinear levels. If the power is too high, the output will be an unstable modulated wave.
- Nonlinear material parameters must have physical meanings.

The following examples explain how to design, simulate, and analyze the nonlinear materials.

2nd Order nonlinear material simulation

Creating the layout

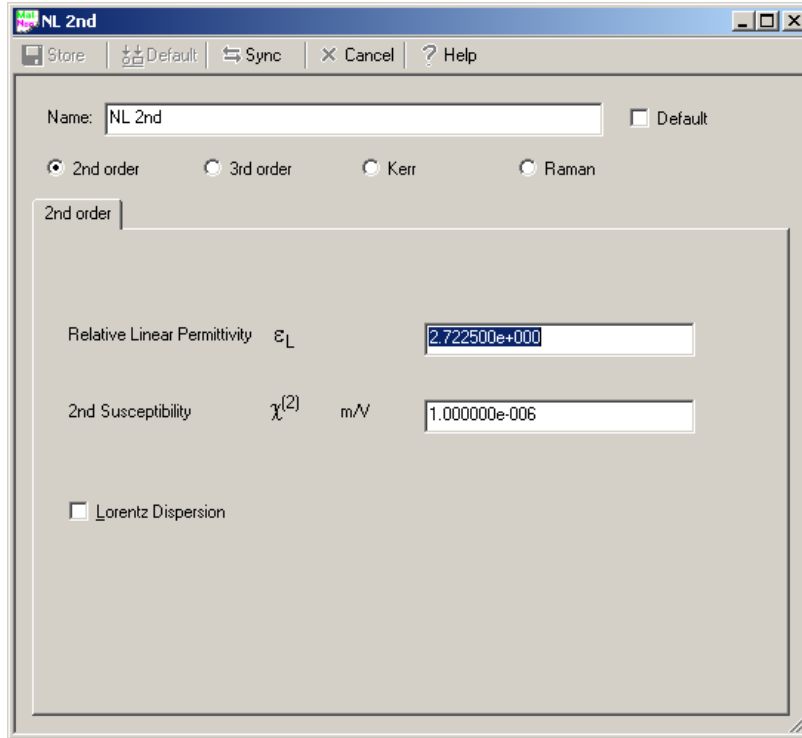
- | Step | Action |
|------|--|
| 1 | Start Waveguide Layout Designer . |
| 2 | To create a new project, select File > New .
<i>The Initial Properties dialog box appears.</i> |
| 3 | Click Profiles and Materials .
<i>The Profile Designer window appears.</i> |
| 4 | Under the Materials folder, right-click the FDTD-Nonlinear folder and select New .
<i>A new FDTDNonlinear1 material dialog box appears.</i> |
| 5 | Select 2nd order .
<i>The 2nd order tab appears in the dialog box.</i> |
| 6 | Select/type the following:
Name: NL 2nd
Relative Linear Permittivity ϵ_L : 2.7225 |



2nd Susceptibility $\chi^{(2)}$ m/V : **1.0e-6**

- 7 To save the material, click **Store**.

Figure 8 FDTDNonlinear1 material definition dialog box



- 8 Under the **Materials** folder, right-click the **Dielectric** folder and select **New**. A new **FDTDDielectric1** material dialog box appears.

- 9 Select/type the following information:

Name: **Dielectric_1.65**

Const Ref. Idx

N Re: **1.65**

- 10 To save the material, click **Store**.

Dielectric_1.65 appears in the **Dielectric** folder in the directory and in the dialog box title bar.

To define the channel profile, perform the following procedure.

Step Action

- 1 Under the **Profiles** folder, right-click the **Channel** folder and select **New**. The **ChannelPro1** dialog box appears.

- 2 Create the following channel profile:

Profile name: **NL 2nd_1**

2D profile definition



- 3 Material: **NL 2nd**
Click **Store**.



- 4 Create a second profile:
 Profile name: **Dielectric 1.65_1**
 2D profile definition
 Material: **Dielectric 1.65**
- 5 Click **Store**.
- 6 Close the **Profile Designer**.

To define the wafer and waveguide properties, perform the following procedure.

Step Action

- 1 In the **Initial Properties** dialog box, type/select the following:
 Waveguide Properties
 Width [μm]: **1.0**
 Profile: **NL_2nd_1**
 Wafer Dimensions
 Length [μm]: **10.0**
 Width [μm]: **5.0**
 2D Wafer Properties
 Material: **Air**
- 2 Click **OK**.
 *The **Initial Properties** dialog box closes and the layout window appears.*

To create the waveguide, perform the following procedure.

Step Action

- 1 From the **Draw** menu, select **Linear Waveguide**.
- 2 In the layout window, drag the linear waveguide from the start point to the end point.
 A linear waveguide appears in the layout window.
- 3 To adjust the position and the shape of the waveguide, in the layout window, double-click the Linear Waveguide.
 *The **Linear Waveguide Properties** dialog box appears.*
- 4 Click the **Start** tab.
- 5 Under **Offset**, type the following values:
 Horizontal: **3**
 Vertical: **0**
- 6 Click the **End** tab.
- 7 Under **Offset**, type the following values:
 Horizontal (μm): **10.0**
 Vertical (μm): **0.0**
- 8 In **Channel Thickness Tapering**, select **Use Default (Channel:None)**.



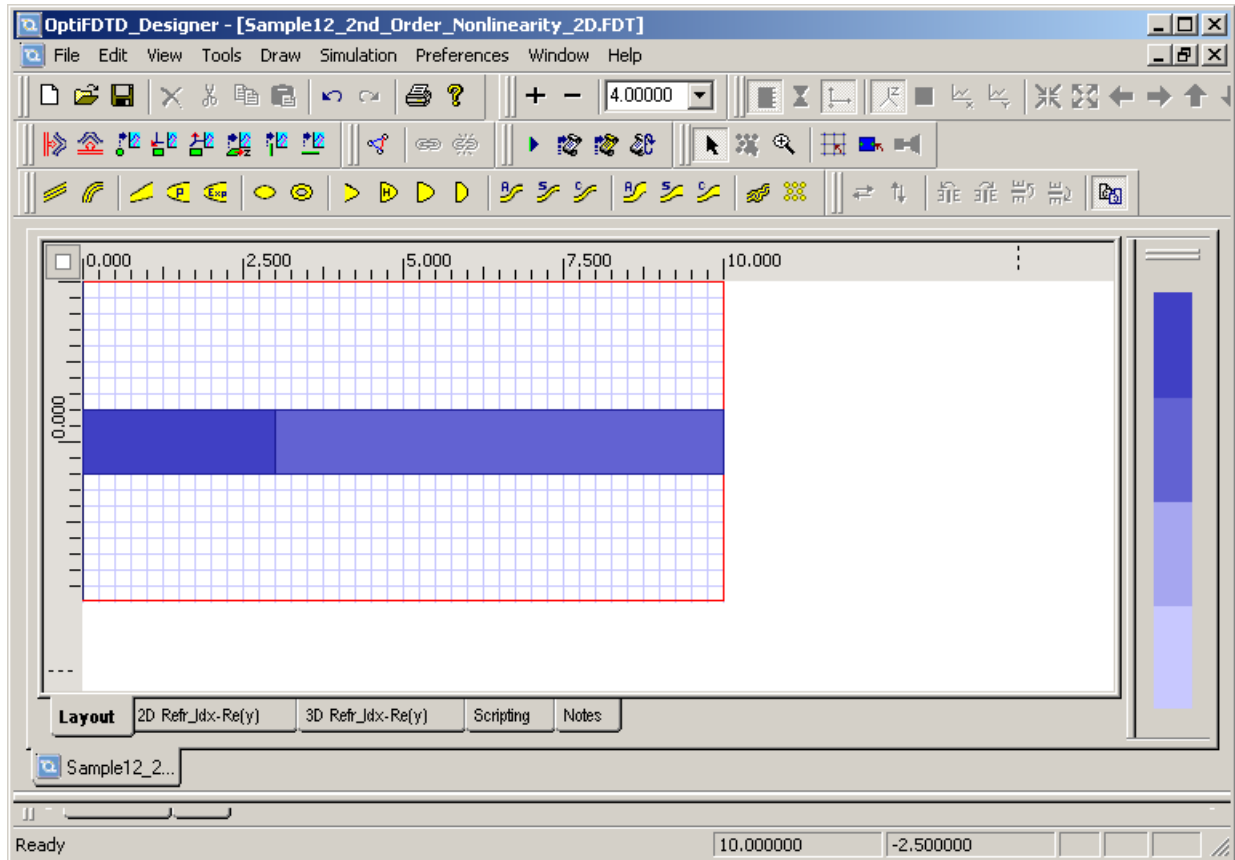
- 9 Type/select the following:
Width (μm): 1.0
Depth (μm): 0.0
Label: **Linear2**
Profile: **NL 2nd_1**
- 10 Repeat steps [1] through [9] to create another linear waveguide in the layout.

Step Action

- 1 In **Start > Offset**, type the following values.
Horizontal: 0
Vertical: 0
- 2 In **End > Offset**, type the following values:
Horizontal: 3
Vertical: 0
- 3 Type/select the following:
Width (μm): 1.0
Depth (μm): 0.0
Label: **Linear1**
Profile: **Dielectric 1.65_1**

The two waveguides appear in the layout. The one on the left is the linear waveguide, and the one on the right is the nonlinear waveguide (see [Figure 9](#)).

Figure 9 Waveguides in layout



Inserting the input plane

To insert the input plane, perform the following procedure.

- | Step | Action |
|-------------|--|
| 1 | From the Draw menu, select Vertical Input Plane . |
| 2 | To insert the input plane, click in the layout window where you want it placed.
<i>The input plane appears in the layout.</i> |
| 3 | To edit the input plane, double-click on the input plane in the layout.
<i>The Input Plane Properties dialog box appears.</i> |
| 4 | Select Continuous Wave . |
| 5 | Set Wavelength to 1.5 μm . |
| 6 | On the General tab, type/select the following:
Input Field Transverse: Modal
Plane Geometry
Z Position [μm]: 1.25
Positive direction |



- 7 On the **2D Transverse** tab, click **Find Modes**.
*The **Mode Solver 2D** dialog box appears.*
- 8 On the **Waveguides** tab, select **Linear1**.
- 9 Click **Calculate Mode**.
*The **Modes** tab is activated.*
- 10 On the **Modes** tab, select the mode.
- 11 Click **Apply Data**.
*The **Mode Solver 2D** closes.*
- 12 On the **2D Transverse** tab, select the **Power** radio button, and type the following:
Power [W/m]: 16 . 0
- 13 Click **OK**.
*The **Input Field Properties** dialog box closes.*

Setting up the Observation Point

- | Step | Action |
|------|---|
| 1 | From the Draw menu, select Observation Point . |
| 2 | Place the Observation Point in the desired position in the layout. |
| 3 | Double-click the observation point.
<i>The Observation Properties -- Point dialog box appears.</i> |
| 4 | On the General tab:
In Center, Offset , type/select the following:
Horizontal: 2 . 5 μm
Vertical: 0 . 0 μm
Center depth: 0 . 0 μm
Label: ObservationPoint1 |
| 5 | On the Data Components tab, ensure that 2D TE: Ey is selected (default). |
| 6 | Click OK .
<i>The Observation Properties -- Point dialog box closes.</i> |
- Repeat steps 1 to 5 to create the following additional observation points with the following information:
- On the **General** tab:
In **Center, Offset**, type/select the following:
Horizontal: 4 . 5 μm
Vertical: 0 . 0 μm
Center depth: 0 . 0 μm
Label: **ObservationPoint2**
- Click **OK**.



On the **General** tab:

In **Center, Offset**, type/select the following:

Horizontal: **6.0 μm**

Vertical: **0.0 μm**

Center depth: **0.0 μm**

Label: **ObservationPoint3**

Click **OK**.

On the **General** tab:

In **Center, Offset**, type/select the following:

Horizontal: **7.4 μm**

Vertical: **0.0 μm**

Center depth: **0.0 μm**

Label: **ObservationPoint4**

Click **OK**.

On the **General** tab:

In **Center, Offset**, type/select the following:

Horizontal: **9.0 μm**

Vertical: **0.0 μm**

Center depth: **0.0 μm**

Label: **ObservationPoint5**

Click **OK**.

On the **General** tab:

In **Center, Offset**, type/select the following:

Horizontal: **0.625 μm**

Vertical: **0.0 μm**

Center depth: **0.0 μm**

Label: **ObservationPoint6**

Click **OK**.

Setting the observation area

- | Step | Action |
|-------------|---|
| 1 | From the Draw menu, select Observation XZ . |
| 2 | Place the Observation Area in the desired position in the layout. |
| 3 | Double-click the observation area.
<i>The Observation Properties -- XZ Area dialog box appears.</i> |



- 4 On the **General** tab:
 In **Center, Offset**, type/select the following:
 Horizontal: $3.0\ \mu\text{m}$
 Vertical: $0.0\ \mu\text{m}$
 Center depth: $0.0\ \mu\text{m}$
 Z length: + 1.5
 X length: + 1.5
 Label: **ObservationArea1**
- 5 On the **Data Components** tab, select the following:
 2D TE: **E_y, H_x, H_z**
- 6 Click **OK**.

Setting the observation line

The observation line is only used for 2D simulations. It is used to show

- field distribution along the line for the user input wavelength
- calculate the outgoing power in the line for user input wavelength
- calculate the absolute power spectrum and normalized transmittance power spectrum (to the input power)

Step Action

- 1 From the **Draw** menu, select **Observation Vertical Line**.
- 2 Place the **Observation Line** in the desired position in the layout.
- 3 Double-click the observation line.
*The **Observation Properties -- Vertical Line** dialog box appears.*
- 4 On the **General** tab:
 In **Center, Offset**, type/select the following:
 Horizontal: $9.5\ \mu\text{m}$
 Vertical: $0.0\ \mu\text{m}$
 X length: + 2.0
 Label: **ObservationLine1**
- 5 On the **Data Components** tab, select the following:
 2D TE: **E_y, H_x, H_z**
- 6 Click **OK**.
 Repeat steps 1 to 5 to create an additional observation line with the following information:
- 7 On the **General** tab:
 In **Center, Offset**, type/select the following:
 Horizontal: $6.5\ \mu\text{m}$
 Vertical: $0.0\ \mu\text{m}$



X length: + 2.0

Label: **ObservationLine2**

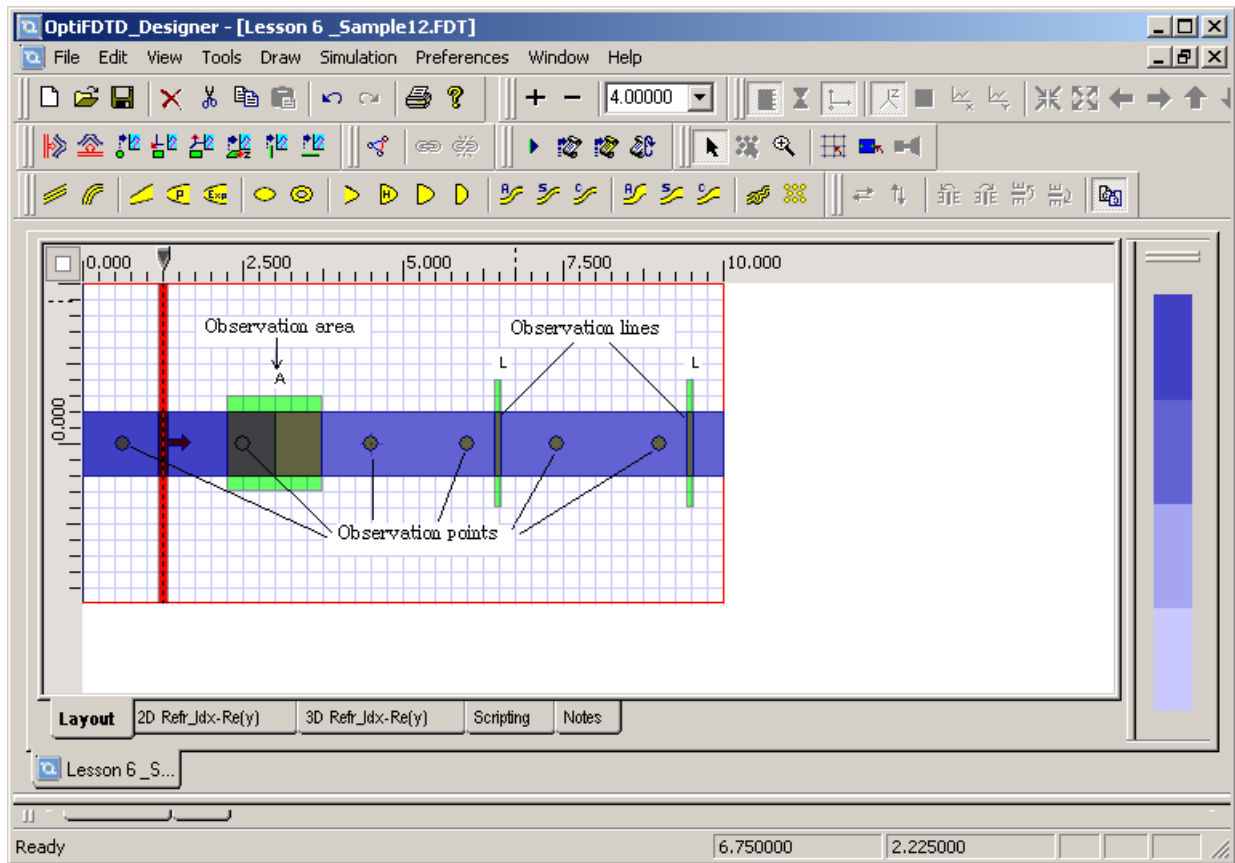
8 On the **Data Components** tab, select the following:

2D TE: **E_y**, **H_x**

9 Click **OK**.

The observation components of the project can be seen in [Figure 10](#).

Figure 10 Observation components of project



Setting the 2D simulation parameters

Step **Action**

1 From the **Simulation** menu, select **2D Simulation Parameters**.
The **Simulation Parameters** dialog box appears (see [Figure 11](#)).

2 Type/select the following information:

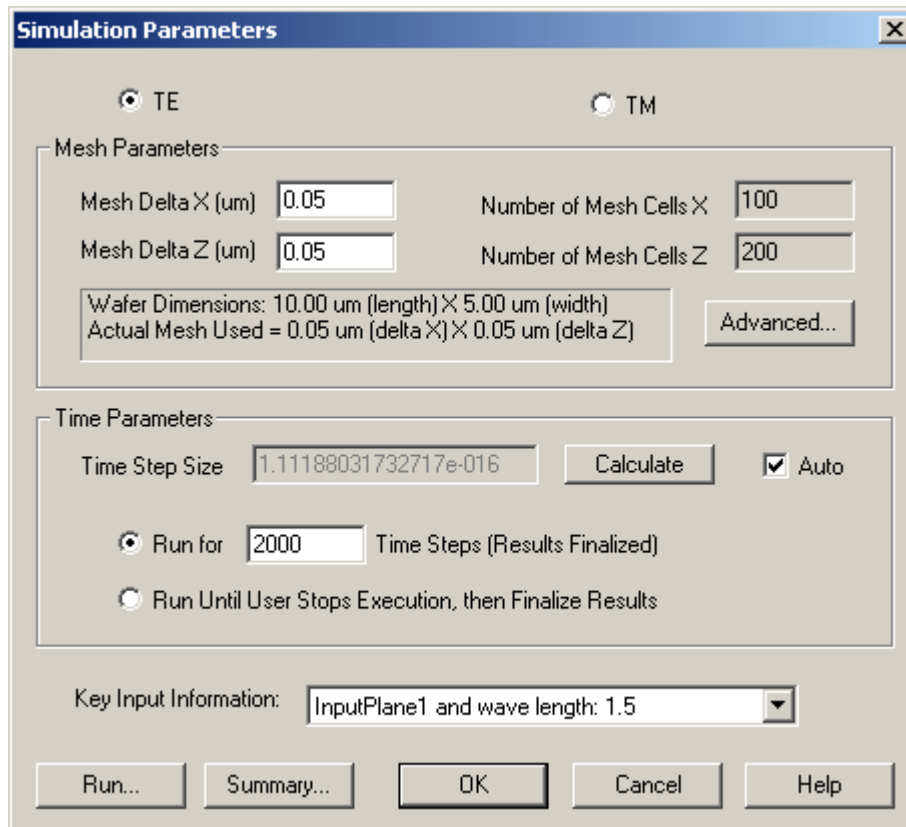
Polarization: **TE**

Mesh Delta X [μm]: **0.05**

Mesh Delta Y [μm]: **0.05**



Figure 11 Simulation Parameters dialog box



- 3 Click **Advanced...**
*The **Boundary Conditions** dialog box appears.*
- 4 Type/select the following information:
 - Anisotropic PML Calculation Parameters
 - Number of Anisotropic PML Layers: 20
 - Theoretical Reflection Coefficient: $1.0e-12$
 - Real Anisotropic PML Tensor Parameters: 5.0
 - Power of Grading Polynomial: 3.5
- 5 In Time Parameters, click **Calculate**.
The default time step size is calculated.
- 6 Select **Run for 2000 Time Steps (Results Finalized)**.
- 7 Select **Key Input Information: Input Plane1 and wavelength:1.5**.
Note: The input plane's center wavelength is used for DFT calculations.
- 8 Click **OK** to close the **Simulation Parameters** dialog box without running the simulation, or click **Run** to start the **OptiFDTD Simulator**.

Note: Before running the simulation, save the project to a file.



Observing the simulation results in OptiFDTD Simulator

Key things to observe:

- Field propagation pattern in OptiFDTD Simulator (see [Figure 12](#))

Select **View > Observation Point** to observe the dynamic time domain and frequency domain response (see [Figure 13](#)).

Figure 12 Field propagation pattern

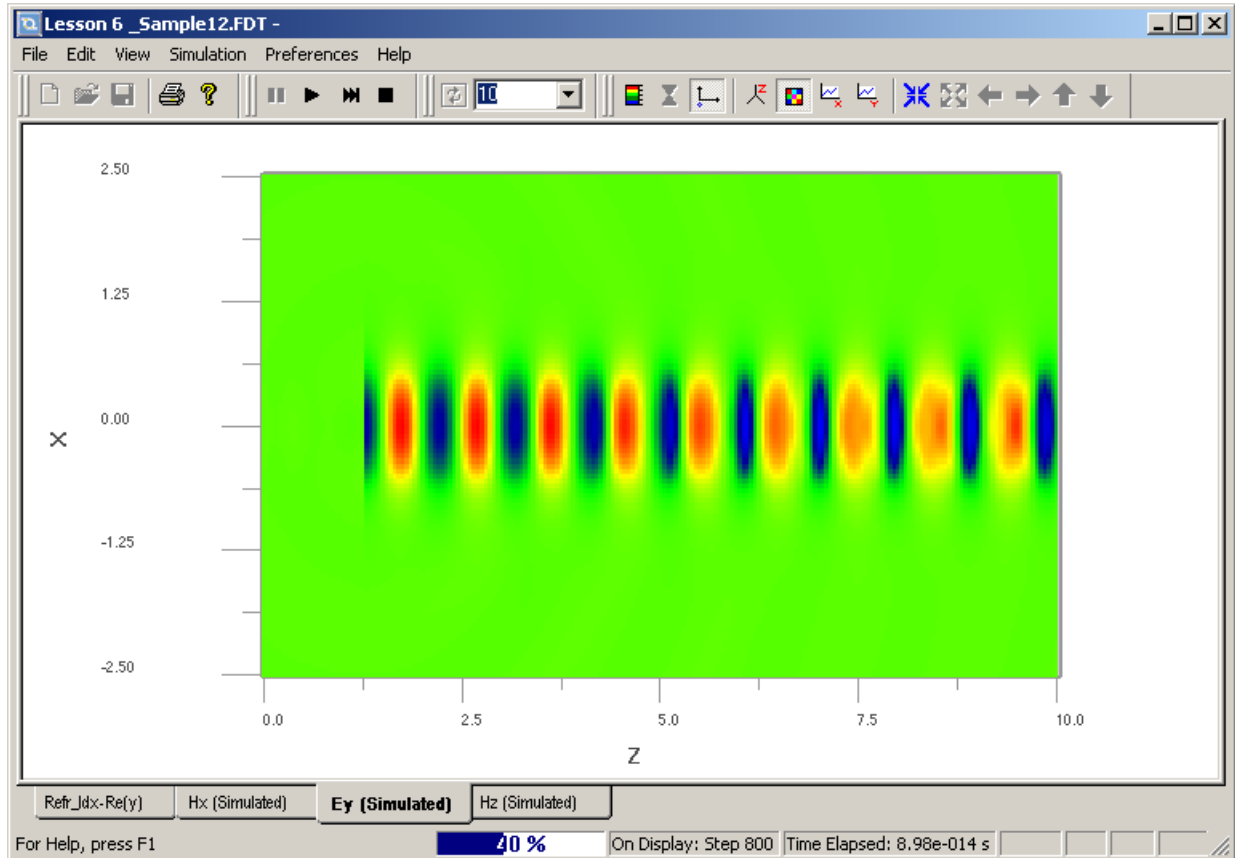
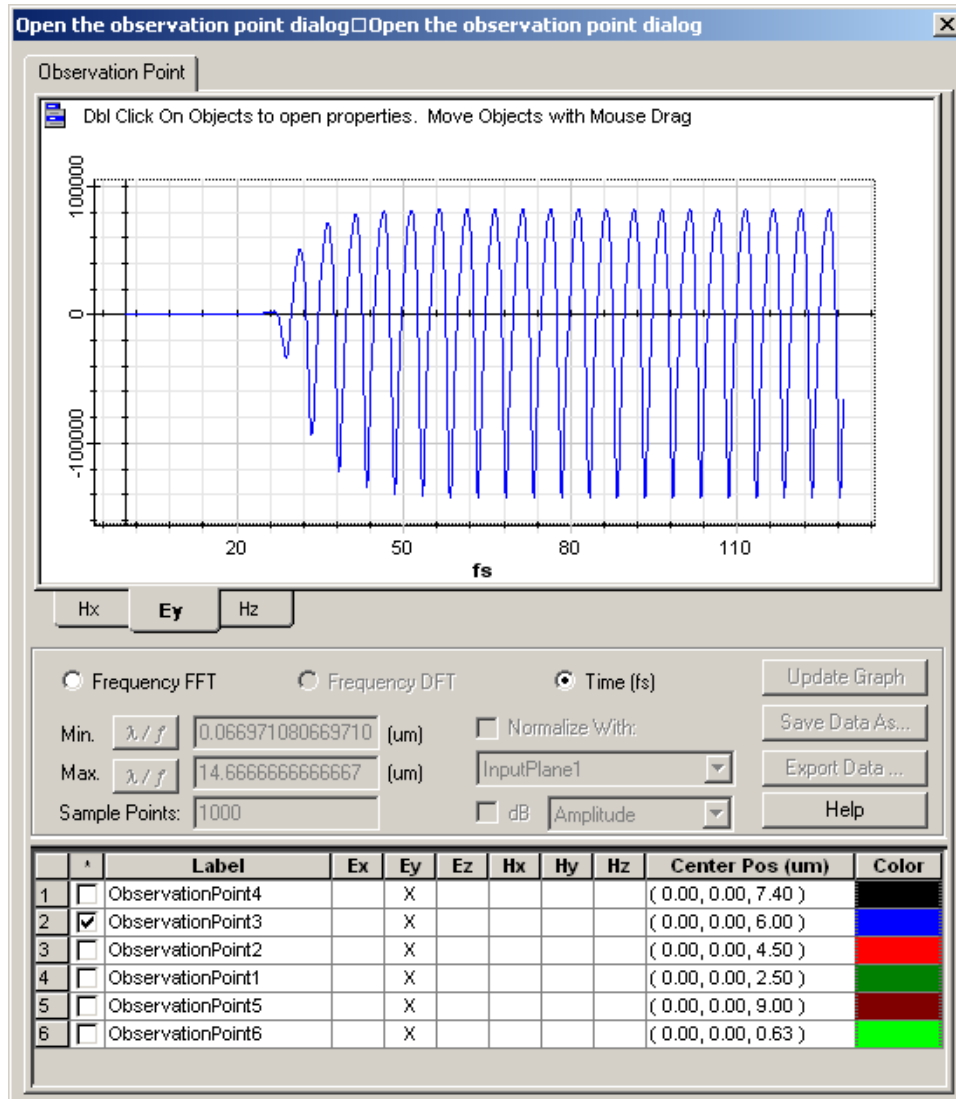


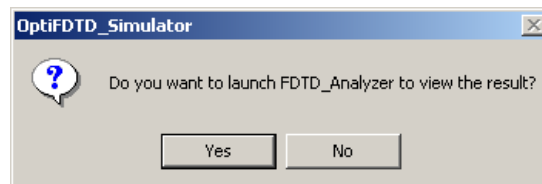
Figure 13 Observation point



Performing data analysis

When the simulation ends, a message appears and prompts you to open OptiFDTD_Analyzer (see Figure 23).

Figure 14 Message box



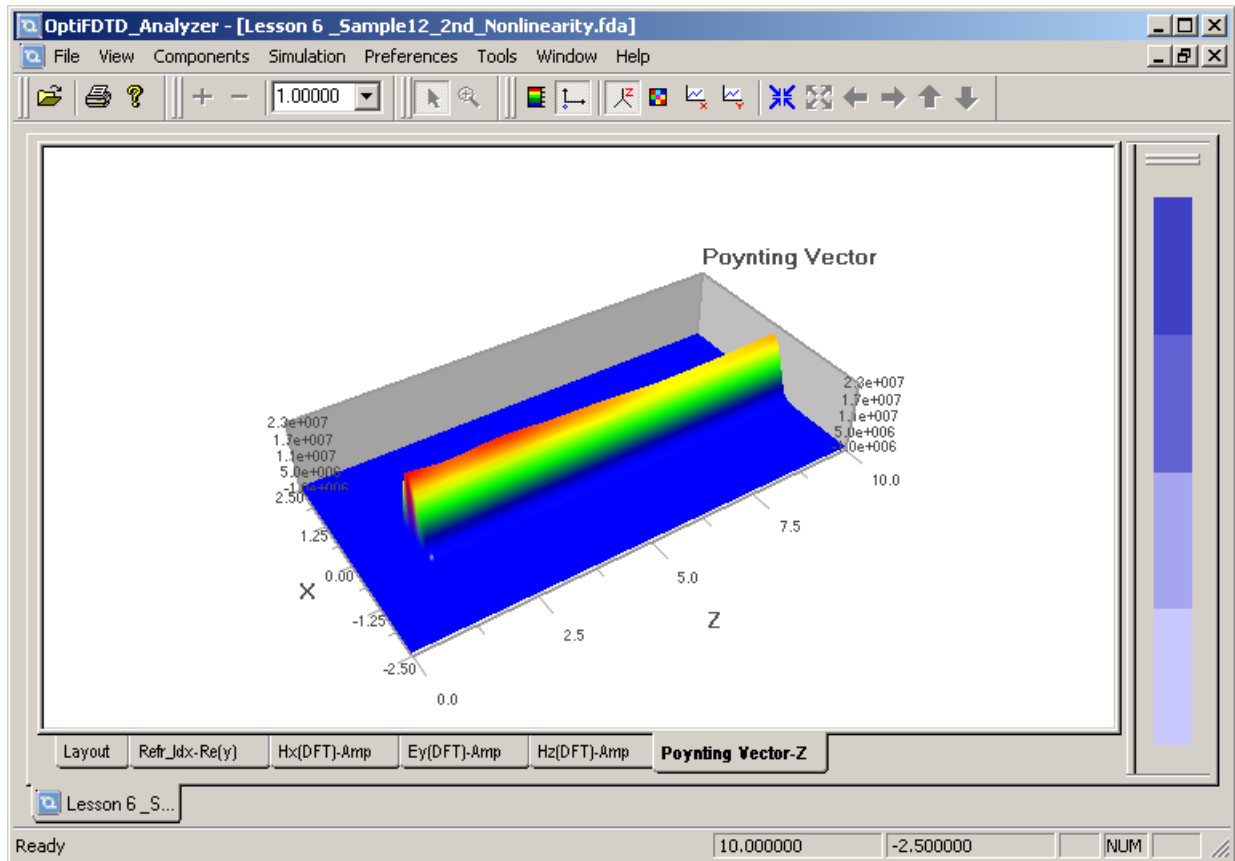
Action

- To open **OptiFDTD_Analyzer** and view the simulated results, click **Yes**.

Note: When the simulation ends in **OptiFDTD_Simulator**, the results are saved automatically as a file with same name, but with a different file extension (***.fda**).

Observe the layout, refractive index, Poynting vector, and field propagation pattern (DFT results) for the input wavelength (see [Figure 15](#) for Poynting vector in z-direction).

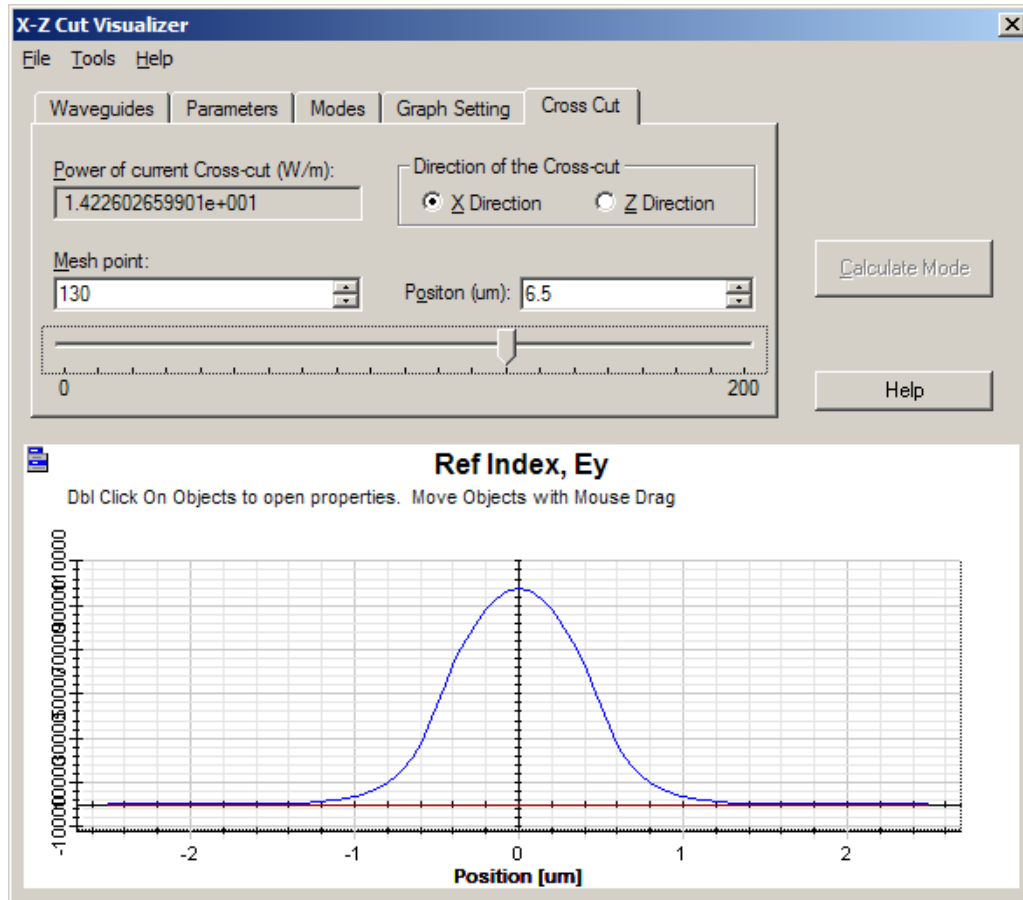
Figure 15 Poynting vector in z-direction



- Select **Tools > Crosscut Viewer**.
The **X-Z Cut Visualizer** dialog box appears.

You can do the mode analysis, mode overlap integral calculation, slice power calculation, and far field transformation (see [Figure 16](#)).

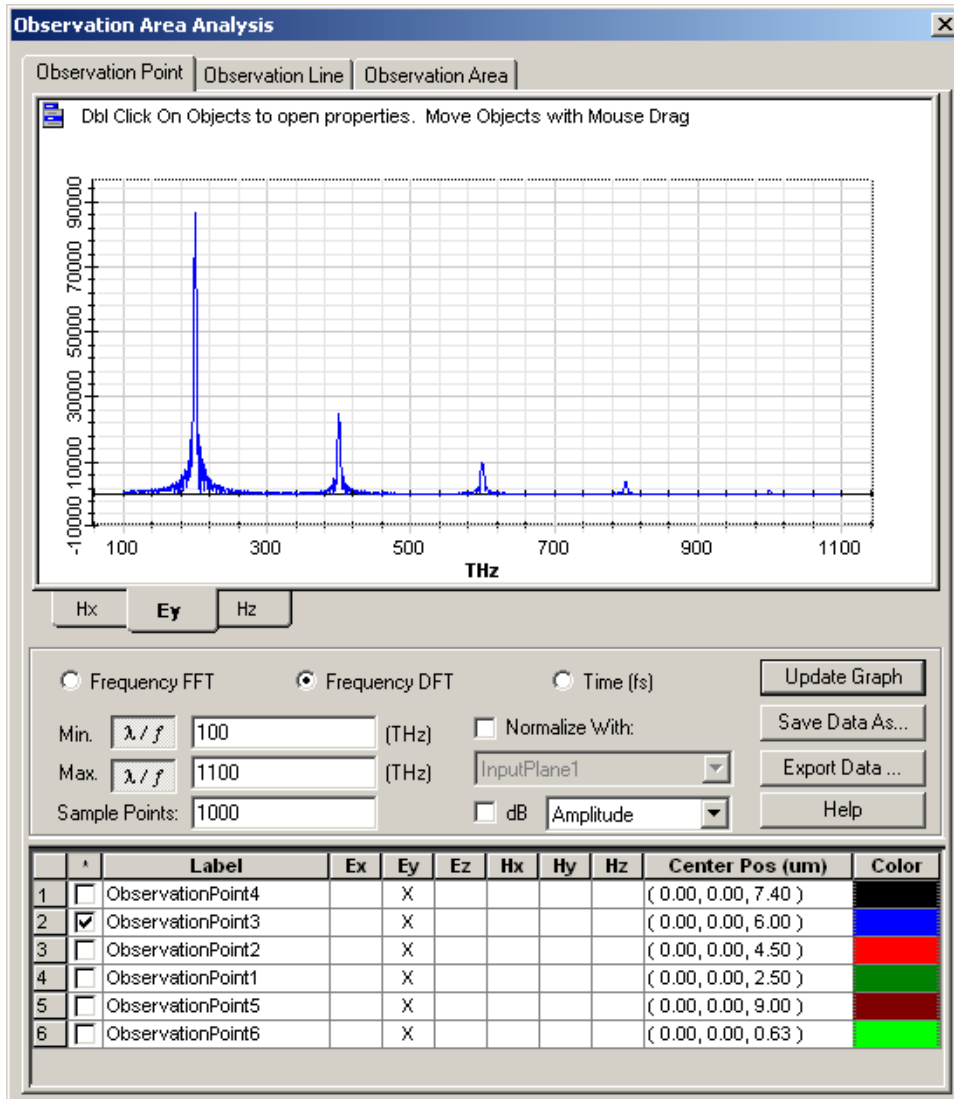
Figure 16 X-Z Cut Visualizer



- Select **Tools > Observation Area Analysis**.
The **Observation Area Analysis** dialog box appears (see [Figure 17](#)).

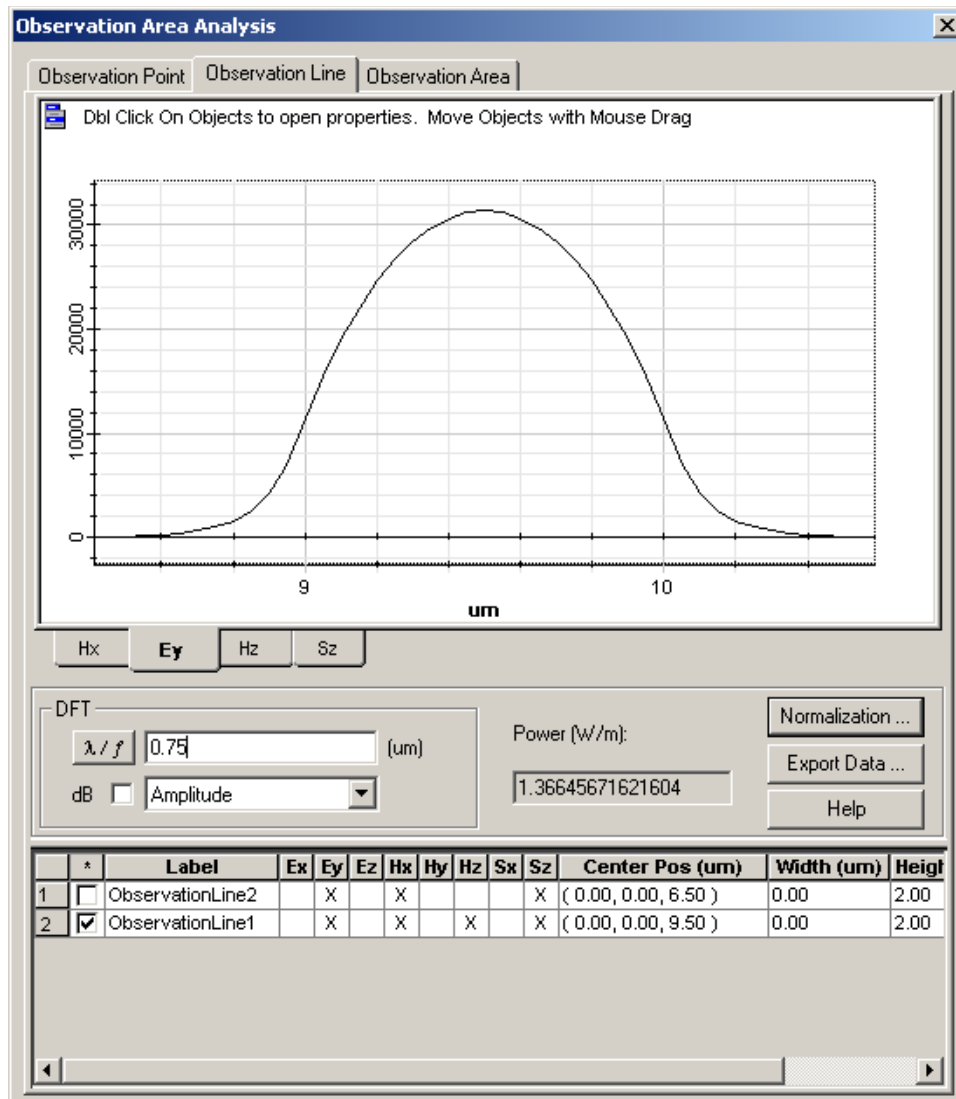


Figure 17 Observation Area Analysis dialog box



- Click the **Observation Line** tab to start the observation line analysis. *The field pattern and the corresponding power for the user input wavelength in the observation line appear in the dialog box (see [Figure 18](#)).*

Figure 18 Observation field pattern and power in observation line



You can also follow the same procedure to perform another nonlinear material simulation.

See the following sample files:

- **Sample12_2D_TE_3rd_Order_Nonlinear.fdt**
- **Sample13_2D_TE_Kerr_Nonlinear.fdt**

In general, the Kerr effect and Raman effect belong to the 3rd-order nonlinearity. However, the Kerr effect uses a special model to consider photonic response time, while the Raman model considers both the response time and the oscillating frequency.



Lesson 7—Four wave mixing

OptiFDTD provides two dimension nonlinearity and multiple input wave simulations, thereby enabling you to simulate the Four Wave Mixing (FWM) effect. The following lesson outlines how OptiFDTD performs a FWM simulation.

To create the Four Wave Mixing layout, perform the following procedures.

Designing a four-wave mixing layout

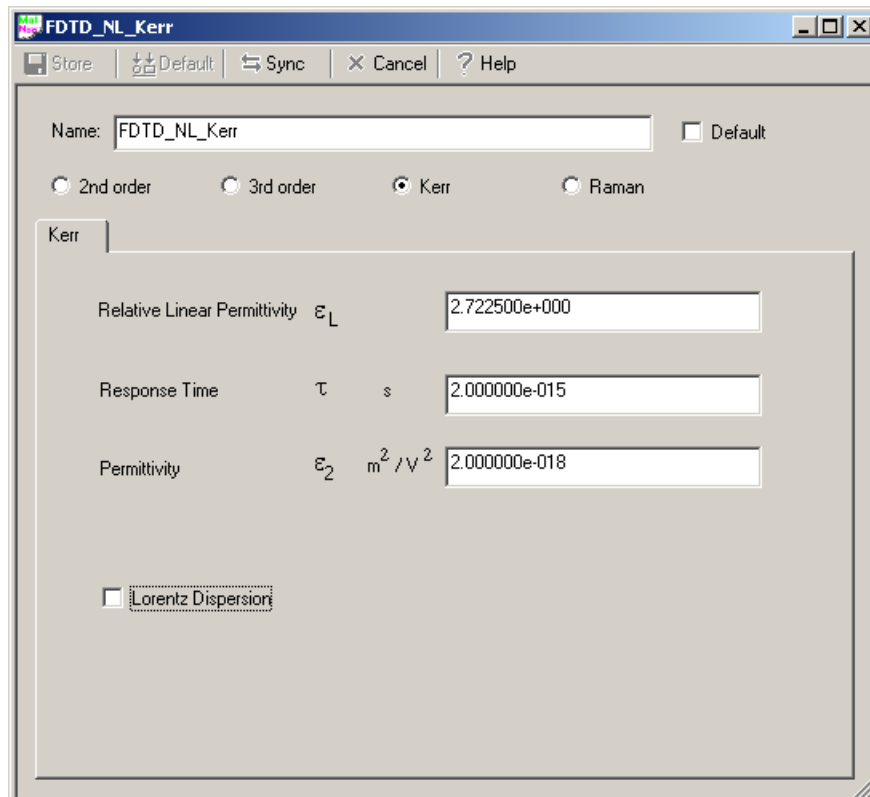
To design the four-wave mixing materials, perform the following procedures.

- | Step | Action |
|-------------|--|
| 1 | Start Waveguide Layout Designer . |
| 2 | To create a new project, select File > New .
<i>The Initial Properties dialog box appears.</i> |
| 3 | Click Profiles and Materials .
<i>The Profile Designer window appears.</i> |
| 4 | Under the Materials folder, right-click the Dielectric folder and select New .
<i>A new FDTDDielectric1 material dialog box appears.</i> |
| 5 | Select/type the following information:
<div style="margin-left: 40px;">Name: FDTD_1.65</div> <div style="margin-left: 40px;">Const Ref. Idx</div> <div style="margin-left: 40px;">N Re: 1.65</div> |
| 6 | To save the material, click Store .
<i>FDTD_1.65 appears in the Dielectric folder in the directory and in the dialog box title bar.</i> |
| 7 | Under the Materials folder, right-click the FDTD-Nonlinear folder and select New .
<i>A new FDTDNonlinear1 material dialog box appears.</i> |
| 8 | Select Kerr .
<i>The Kerr tab appears in the dialog box.</i> |



- 9 Select/type the following:
 - Name: **FDTD_NL_Kerr**
 - Relative Linear Permittivity: **2.7225**
 - Response Time: **2.0e-15**
 - Permittivity: **2.0e-18**
- 10 To save the material, click **Store**.

Figure 19 FDTD_NL_Kerr material



To define the channel profile, perform the following procedure.

- | Step | Action |
|-------------|--|
| 1 | Under the Profiles folder, right-click the Channel folder and select New .
<i>The ChannelPro1 dialog box appears.</i> |
| 2 | Create the following channel profile: <ul style="list-style-type: none"> Profile name: NL_Kerr 2D profile definition Material: FDTD_NL_Kerr |
| 3 | Click Store . |

- 4 Create a second profile:
 - Profile name: **Linear_WG**
 - 2D profile definition
 - Material: **FDTD_1.65**
- 5 Click **Store**.
- 6 Close the **Profile Designer**.

To define the wafer and waveguide properties, perform the following procedure.

Step Action

- 1 In the **Initial Properties** dialog box, , type/select the following:
 - Waveguide Properties**
 - Width [μm]: **1.0**
 - Profile: **NL_Kerr**
 - Wafer Dimensions**
 - Length [μm]: **15.0**
 - Width [μm]: **10.0**
 - 2D Wafer Properties**
 - Material: **Air**
- 2 Click **OK**.
*The **Initial Properties** dialog box closes and the layout window appears.*

To create the waveguide, perform the following procedure.

Step Action

- 1 From the **Draw** menu, select **Linear Waveguide**.
- 2 In the layout window, drag the linear waveguide from the start point to the end point.
A linear waveguide appears in the layout window.

Note: Release the **Linear Waveguide** selection tool by clicking the **Select tool** after the **Linear Waveguide** is drawn in the layout.

- 3 To adjust the position and the shape of the waveguide, in the layout window, double-click the Linear Waveguide.
*The **Linear Waveguide Properties** dialog box appears.*
- 4 Click the **Start** tab.
- 5 Under **Offset**, type the following values:
 - Horizontal: **4.0**
 - Vertical: **0**
- 6 Click the **End** tab.
- 7 Under **Offset**, type the following values:
 - Horizontal (μm): **13.00**
 - Vertical (μm): **0.0**



8 In **Channel Thickness Tapering**, select **Use Default (Channel:None)**.

9 Type/select the following:

Width (μm): 8.0

Depth (μm): 0.0

Label: **linear4**

Profile: **NL_Kerr**

10 Click **OK**.

11 Repeat steps [1] through [3] to create three input linear waveguides in the layout.

Note: The input waveguide is used to input three different wavelength waves into the nonlinear material.

Input Waveguide 1 properties:

Step Action

1 In **Start > Offset**, type the following values.

Horizontal: 0

Vertical: 0

2 In **End > Offset**, type the following values:

Horizontal: 4

Vertical: 0

3 In **Channel Thickness Tapering**, select **Use Default (Channel:None)**.

4 Type/select the following:

Width (μm): 1.0

Label: **linear1**

Depth (μm): 0.0

Profile: **Linear_WG**

5 Click **OK**.

Input Waveguide 2 properties:

Step Action

1 In **Start > Offset**, type the following values.

Horizontal: 0

Vertical: 1.2

2 In **End > Offset**, type the following values:

Horizontal: 4

Vertical: 1.2



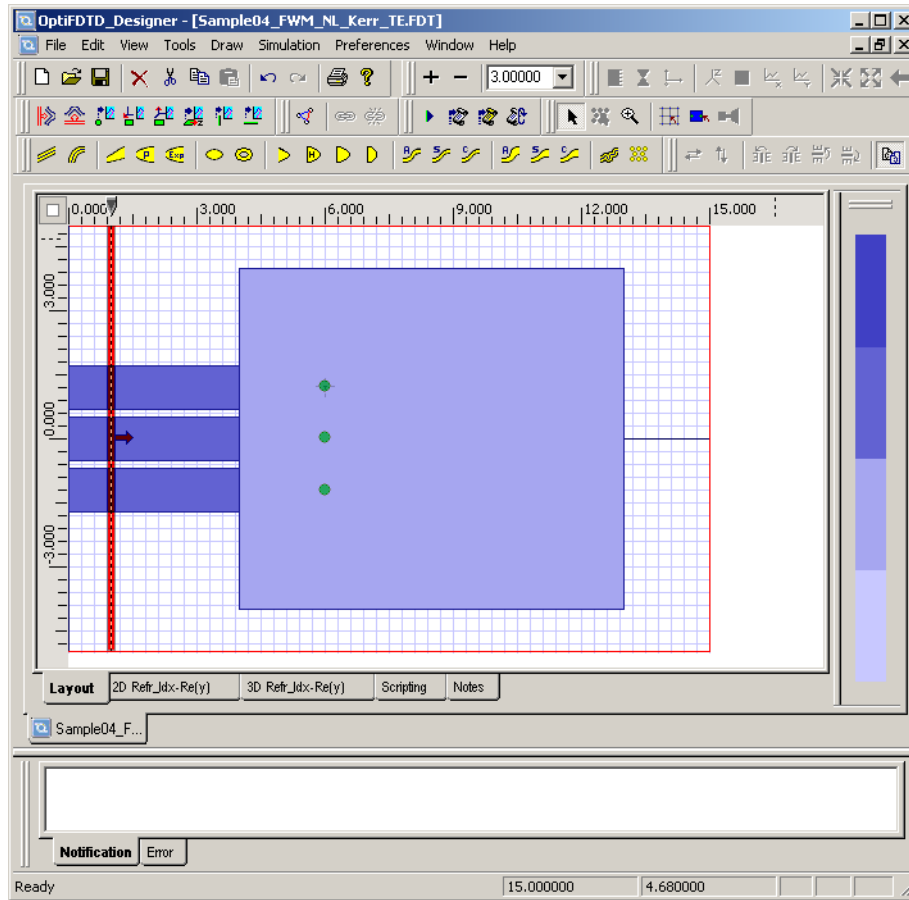
- 3 In **Channel Thickness Tapering**, select **Use Default (Channel:None)**.
- 4 Type/select the following:
 - Width (μm): 1.0
 - Depth (μm): 0.0
 - Label: **linear2**
 - Profile: **Linear_WG**
- 5 Click **OK**.

Input Waveguide 3 properties:

- | Step | Action |
|-------------|--|
| 1 | In Start > Offset , type the following values. <ul style="list-style-type: none">Horizontal: 0Vertical: -1.2 |
| 2 | In End > Offset , type the following values: <ul style="list-style-type: none">Horizontal: 4Vertical: -1.2 |
| 3 | In Channel Thickness Tapering , select Use Default (Channel:None) . |
| 4 | Type/select the following: <ul style="list-style-type: none">Width (μm): 1.0Depth (μm): 0.0Label: linear3Profile: Linear_WG |
| 5 | Click OK . |



Figure 20 Input waveguides



Setting the input wave

- | Step | Action |
|------|---|
| 1 | From the Draw menu, select Vertical Input Plane . |
| 2 | To insert the input plane, click in the layout window where you want it placed.
<i>The input plane appears in the layout.</i> |
| 3 | To edit the input plane, double-click on the input plane in the layout.
<i>The Input Plane Properties dialog box appears.</i> |
| 4 | On the General tab, type/select the following:

<div style="margin-left: 40px;"> <p>Continuous Wave</p> <p>Wavelength [μm]: 1.4</p> <p>Input Field Transverse: Modal</p> <p>Plane Geometry:</p> <div style="margin-left: 40px;"> <p>Z Position [μm]: 1.0</p> </div> </div> |



- 5 On the **2D Transverse** tab, click **Find Modes**.
*The **Mode Solver 2D** dialog box appears.*
- 6 On the **Waveguides** tab, select **Linear1**.
- 7 Click **Calculate Mode**.
*The **Modes** tab is activated.*
- 8 On the **Modes** tab, select the mode.
- 9 Click **Apply Data**.
*The **Mode Solver 2D** closes.*
- 10 On the **2D Transverse** tab, select the **Amplitude** radio button and type the following:
Amplitude [V/m]: **2.0e09**
- 11 Click **OK**.
*The **Input Field Properties** dialog box closes.*
- 12 Repeat steps [1] through [10] to create a second vertical input plane with the following data:
Vertical Input Plane 2 properties:

- | Step | Action |
|-------------|--|
| 1 | In the Input Field Properties dialog box, select/type the following:
Continuous Wave
Wavelength [μm]: 1.55 |
| 2 | On the General tab, type/select the following:
Input Field Transverse: Mode1
Plane Geometry:
Z Position [μm]: 1.0 |
| 3 | Click Find Modes .
<i>The Mode Solver 2D dialog box appears.</i> |
| 4 | On the Waveguides tab, select Linear2 . |
| 5 | Click Calculate Mode .
<i>The Modes tab is activated.</i> |
| 6 | On the Modes tab, select the mode. |
| 7 | Click Apply Data .
<i>The Mode Solver 2D closes.</i> |
| 8 | On the 2D Transverse tab, select the Amplitude radio button and type the following:
Amplitude [V/m]: 2.0e09 |
| 9 | Click OK .
<i>The Input Field Properties dialog box closes.</i> |



Vertical Input Plane 3 properties:

- | Step | Action |
|-------------|---|
| 1 | In the Input Field Properties dialog box, select/type the following:
<div style="margin-left: 40px;">Continuous Wave
 Wavelength [μm]: 1.60</div> |
| 2 | On the General tab, type/select the following:
<div style="margin-left: 40px;">Input Field Transverse: Modal
 Plane Geometry:
 Z Position [μm]: 1.0</div> |
| 3 | Click Find Modes .
<i>The Mode Solver 2D dialog box appears.</i> |
| 4 | On the Waveguides tab, select Linear3 . |
| 5 | Click Calculate Mode .
<i>The Modes tab is activated.</i> |
| 6 | On the Modes tab, select the mode. |
| 7 | Click Apply Data .
<i>The Mode Solver 2D closes.</i> |
| 8 | On the 2D Transverse tab, select the Amplitude radio button and type the following:
<div style="margin-left: 40px;">Amplitude [V/m]: 2.0e09</div> |
| 9 | Click OK .
<i>The Input Field Properties dialog box closes.</i> |

Setting up the Observation Point

- | Step | Action |
|-------------|--|
| 1 | From the Draw menu, select Observation Point . |
| 2 | Place the Observation Point in the desired position in the layout. |
| 3 | Double-click the observation point.
<i>The Observation Properties -- Point dialog box appears.</i> |
| 4 | On the General tab:
<div style="margin-left: 40px;">In Center, Offset, type/select the following:
 Horizontal: 6.0μm
 Vertical: 0.0μm
 Center depth: 0.0μm
 Label: Observation Point1</div> |



- 5 On the **Data Components** tab, ensure that **2D TE: Ey** is selected (default).
- 6 Click **OK**.
*The **Observation Properties -- Point** dialog box closes.*
- 7 Repeat steps 1 to 5 and create another **Observation Point** with the following information.
- 8 On the **General** tab:
 - In **Center, Offset**, type/select the following:
 - Horizontal: **6.0 μm**
 - Vertical: **1.2 μm**
 - Center depth: **0.0 μm**
 - Label: **Observation Point2**
 - Click **OK**.
- 9 Repeat steps 1 to 5 and create another **Observation Point** with the following information.
- 10 On the **General** tab:
 - In **Center, Offset**, type/select the following:
 - Horizontal: **6.0 μm**
 - Vertical: **-1.2 μm**
 - Center depth: **0.0 μm**
 - Label: **Observation Point3**
- 11 On the **Data Components** tab, ensure that **2D TE: Ey** is selected (default).
- 12 Click **OK**.

Setting the 2D simulation parameters

- | Step | Action |
|-------------|---|
| 1 | From the Simulation menu, select 2D Simulation Parameters .
<i>The Simulation Parameters dialog box appears.</i> |
| 2 | Type/select the following information: <ul style="list-style-type: none"> Polarization: TE Mesh Delta X [μm]: 0.1 Mesh Delta Y [μm]: 0.1 |
| 3 | Click Advanced... .
<i>The Boundary Conditions dialog box appears.</i> |
| 4 | Type/select the following information: <ul style="list-style-type: none"> -X: Anisotropic PML +X: Anisotropic PML -Z: Anisotropic PML +Z: Anisotropic PML |



Anisotropic PML Calculation Parameters

Number of Anisotropic PML Layers: 10

Theoretical Reflection Coefficient: $1.0e-12$

Real Anisotropic PML Tensor Parameters: 5.0

Power of Grading Polynomial: 3.5

- 5 In Time Parameters, click **Calculate**.
The default time step size is calculated.
- 6 Select **Run for 3000 Time Steps (Results Finalized)**.
- 7 Select **Key Input Information: Input Plane1 and wavelength:1.4**.

Note: The input plane's center wavelength is used for DFT calculations.

- 8 Click **OK** to close the **Simulation Parameters** dialog box without running the simulation, or click **Run** to start the **OptiFDTD Simulator**.

Note: Save your layout before starting the simulation.



Observing the simulation results

Key things to observe:

- wave propagation pattern in time domain (see [Figure 21](#))
- field response in time domain and frequency domain for observation point (select **View > Observation Point** to see the dynamic time domain and frequency domain response (see [Figure 22](#)).

Figure 21 OptiFDTD Simulator—wave propagation pattern in time domain

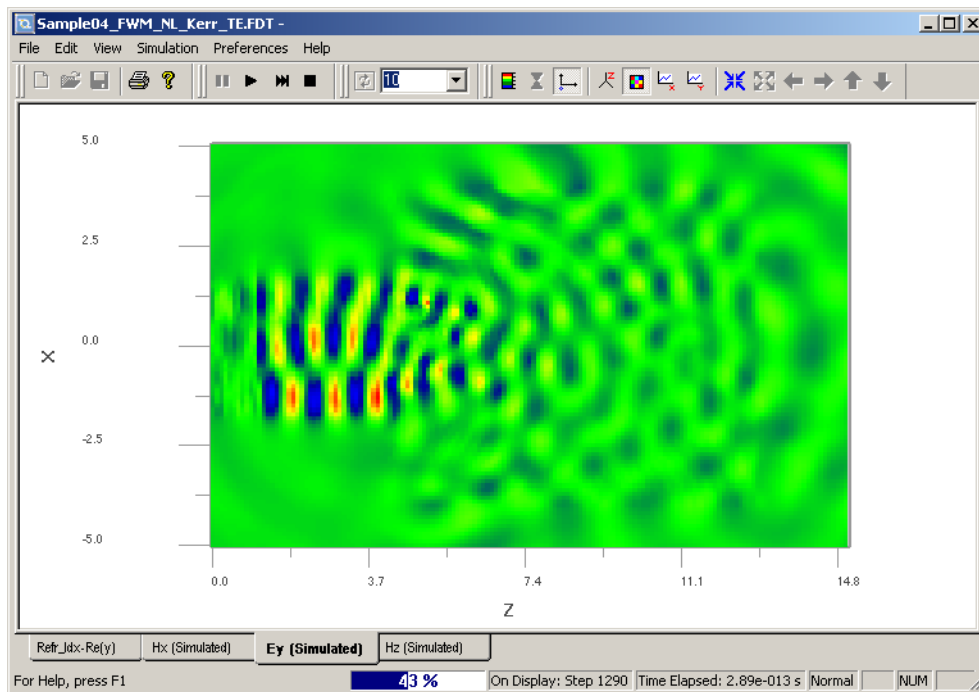
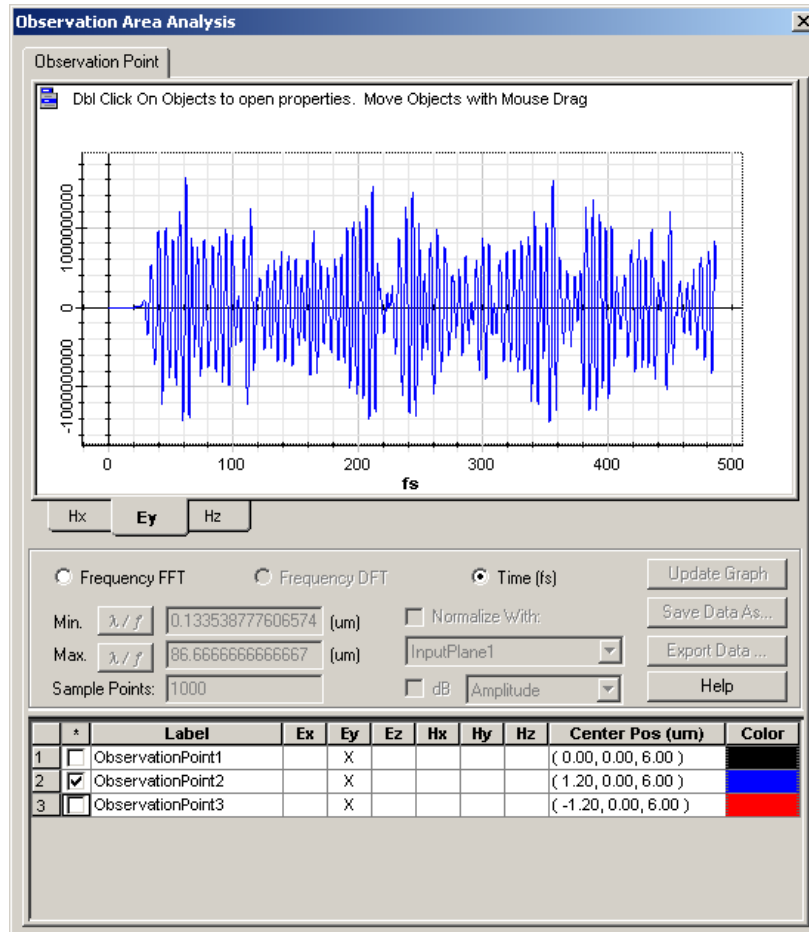


Figure 22 OptiFDTD Simulator—time domain and frequency domain for observation point

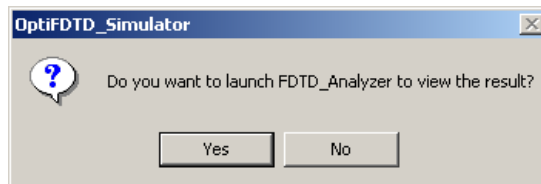


Performing data analysis

Spectral analysis in observation point

When the simulation ends, a message appears and prompts you to open OptiFDTD_Analyzer (see Figure 23).

Figure 23 Message box



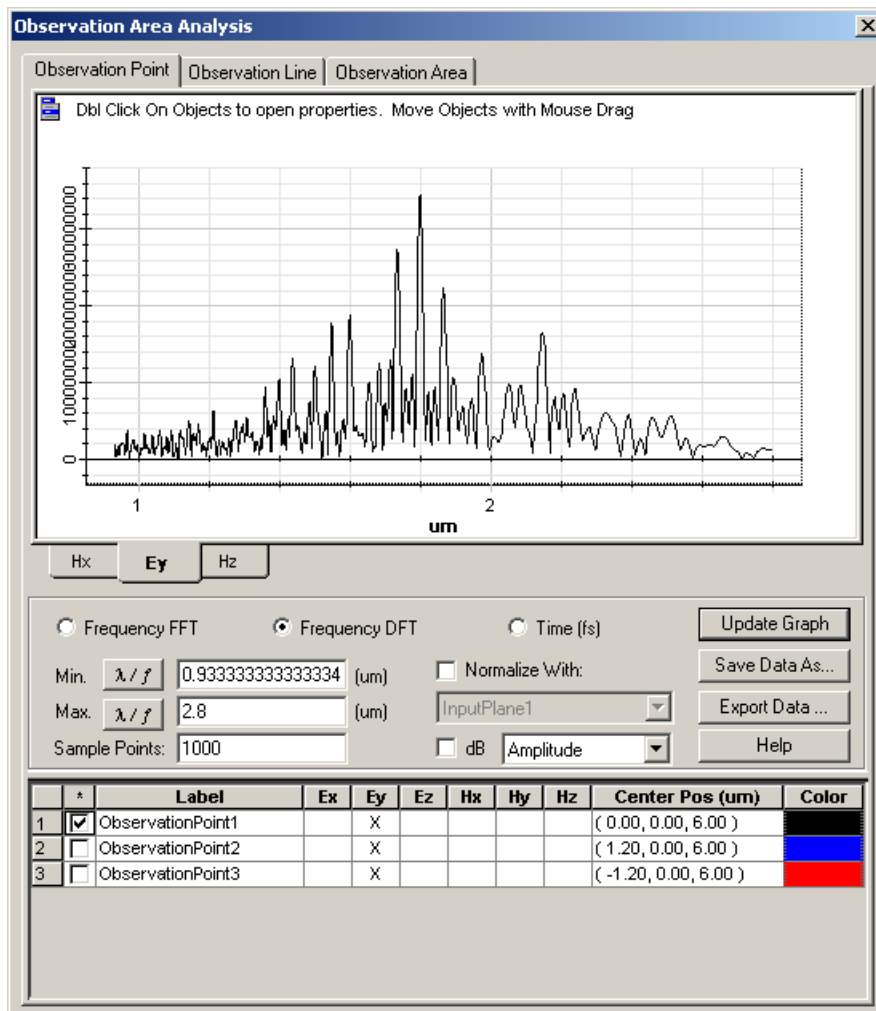
Step Action

- 1 To open **OptiFDTD_Analyzer** and view the simulated results, click **Yes**.

Note: When the simulation ends, the results are saved automatically as a file with same name but a different file extension (* .fda).

- 2 Select **Tools > Observation Area Analysis**.
*The **Observation Area Analysis** dialog box appears.*
- 3 On the **Observation Point** tab, type/select the following:
Observation Point1
Frequency DFT
 Min. λ / f : **0.9 μ m**
 Max. λ / f : **2.8 μ m**
 Sample Point: **1000**
- 4 Click **Update Graph** to view updated results.
*The spectral response in **Observation Point1** are displayed, and the four wave mixing effect can be seen in the curve (see [Figure 24](#)).*

Figure 24 OptiFDTD_Analyzer—Observation point results analysis



Notes:



Lesson 8—Plane wave simulation

OptiFDTD provides two special boundary conditions---perfect electrical conductor (PEC) boundary and perfect magnetic conductor (PMC) boundary. The two boundary conditions can work with Anisotropic PML together to realize the plane wave simulation. For more details of these boundary conditions, please see the Technical Background. This lesson presents a 2D plane wave simulations and 3D plane wave simulation.

Note: Due to the PMC and PEC setting, plane wave simulation is only functional with symmetrical structures.

2D-TE plane wave in unique material

Creating a layout

- | Step | Action |
|------|--|
| 1 | Open the Waveguide Layout Designer . |
| 2 | To create a new project, select File > New .
<i>The Initial Properties dialog box appears.</i> |
| 3 | Click Profiles and Materials .
<i>The Profile Designer window appears.</i> |
| 4 | Under the Materials folder, right-click the Dielectric folder and select New .
<i>A new Dielectric material dialog box appears.</i> |
| 5 | Type the following information:
Name: N=2
Refractive index (Re:): 2 . 0 |
| 6 | To save the material, click Store .
<i>N=2 appears in the Dielectric folder in the directory and in the dialog box title bar.</i> |



Defining the channel profile

- | Step | Action |
|-------------|--|
| 1 | Under the Profiles folder, right-click the Channel folder and select New .
<i>The ChannelPro1 dialog box appears.</i> |
| 2 | Create the following channel profile:
Profile name: Profile_n=2
2D profile definition
Material: N=2
3D profile definition
Layer name: layer_01
Width: 1.0
Thickness: 1.0
Offset: 0.0
Material: N=2
Click Add . |
| 3 | Click Store . |
| 4 | Close the Profile Designer . |

Defining wafer and waveguide properties

- | Step | Action |
|-------------|---|
| 1 | In the Initial Properties dialog box, type/select the following:
Waveguide Properties
Width [μm]: 1.0
Profile: Profile_n=2
Wafer Dimensions
Length [μm]: 8.0
Width [μm]: 4.0
2D Wafer Properties
Material: Air
3D Wafer Properties
Cladding
Thickness [μm]: 2.0
Material: Air
Substrate
Thickness [μm]: 2.0
Material: Air |
| 2 | Click OK .
<i>The Initial Properties dialog box closes.</i> |



Inserting the input plane

To insert the input plane, perform the following procedure.

- | Step | Action |
|-------------|---|
| 1 | From the Draw menu, select Vertical Input Plane . |
| 2 | To insert the input plane, click in the layout window where you want it placed.
<i>The input plane appears in the layout.</i> |
| 3 | To edit the input plane, double-click on the input plane in the layout.
<i>The Input Plane Properties dialog box appears.</i> |
| 4 | On the General tab, type/select the following:

<div style="margin-left: 20px;"> Continuous Wave
 Wavelength [μm]: 1.55
 Input Field Transverse: Rectangular
 Plane Geometry:
 <div style="margin-left: 20px;">Z Position [μm]: 1.0</div> </div> |
| 5 | On the 2D Transverse tab, type/select the following:

<div style="margin-left: 20px;"> Center Position [μm]: 0.0
 Halfwidth [μm]: 5.0
 Tilting Angle [deg]: 0
 Effective Refractive Index: Local
 Amplitude [V/m]: 1.0 </div> |
| 6 | Click OK .
<i>The Input Field Properties dialog box closes.</i> |

Setting the 2D TE FDTD simulation parameters

- | Step | Action |
|-------------|---|
| 1 | From the Simulation menu, select 2D Simulation Parameters .
<i>The Simulation Parameters dialog box appears.</i> |
| 2 | Type/select the following information:

<div style="margin-left: 20px;"> Polarization: TE
 Mesh Delta X [μm]: 0.05
 Mesh Delta Z [μm]: 0.05 </div> |
| 3 | Click Advanced...
<i>The Boundary Conditions dialog box appears.</i>

<div style="margin-left: 20px;"> -X: PMC
 +X: PMC
 -Z: Anisotropic PML
 +Z: Anisotropic PML </div> |



Anisotropic PML Calculation Parameters

Number of Anisotropic PML Layers: **10**

Theoretical Reflection Coefficient: **1.0e-12**

Real Anisotropic PML Tensor Parameters: **5.0**

Power of Grading Polynomial: **3.5**

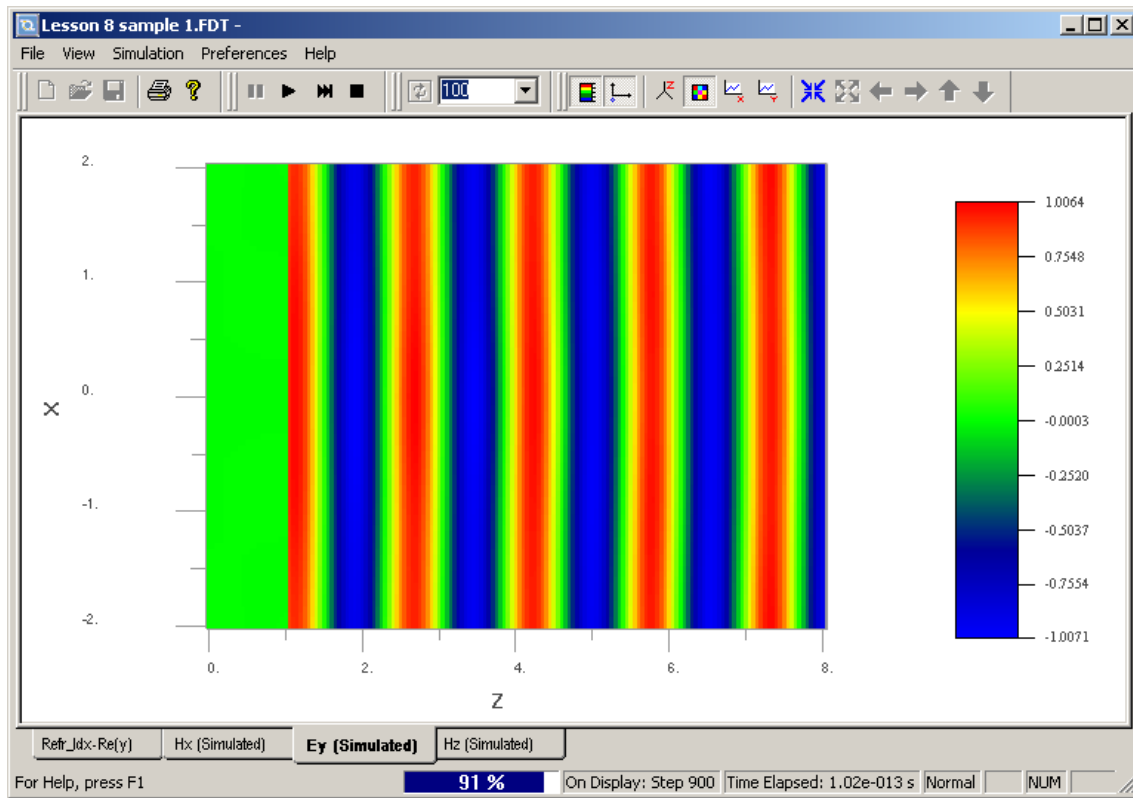
- 4** Click **OK**.
*The **Boundary Conditions** dialog box closes.*
- 5** In Time Parameters, click **Calculate**.
The default time step size is calculated.
- 6** Select **Run for 1000 Time Steps (Results Finalized)**.
- 7** Select **Key Input Information: Input Plane1 and wavelength:1.55**.
- 8** Click **OK** to close the **Simulation Parameters** dialog box without running the simulation, or click **Run** to start the **OptiFDTD Simulator**.



Running the 2D TE plane wave simulation

When you start the simulation, the plane wave propagation can be observed (see [Figure 25](#)).

Figure 25 OptiFDTD Simulator



3D-Y-direction polarized plane wave in unique material

Using the same layout created in [2D-TE plane wave in unique material](#), create another file with the same layout by selecting **File > Save As** and using a different file name.

- | Step | Action |
|-------------|---|
| 1 | From the Edit menu, select Wafer Properties .
<i>The Wafer Properties dialog box appears.</i> |
| 2 | Click the 3D Wafer Properties tab and set the Cladding: Material and Substrate Material to N=2 . |
| 3 | Click OK .
<i>The Wafer Properties dialog box closes.</i> |
| 4 | To edit the input plane, double-click on the input plane in the layout.
<i>The Input Plane Properties dialog box appears.</i> |
| 5 | On the General tab, type/select the following:
<div style="margin-left: 40px;"> Continuous Wave
 Wavelength [μm]: 2.0
 Input Field Transverse: Rectangular
 Plane Geometry:
 <div style="margin-left: 40px;">Z Position [μm]: 1.0</div> </div> |
| 6 | On the 3D Transverse tab, type/select the following:
<div style="margin-left: 40px;"> Center Position [μm] X: 0.0
 Halfwidth [μm] X: 5.0
 Center Position [μm] Y: 0.0
 Halfwidth [μm] Y: 5.0
 Tilting Angle [deg]: 0
 Effective Refractive Index: Local
 Polarization: LinearY
 Select the Amplitude radio button and type:
 <div style="margin-left: 40px;">Amplitude [V/m²]: 1.0</div> </div> |
| 7 | Click OK .
<i>The Input Field Properties dialog box closes.</i> |



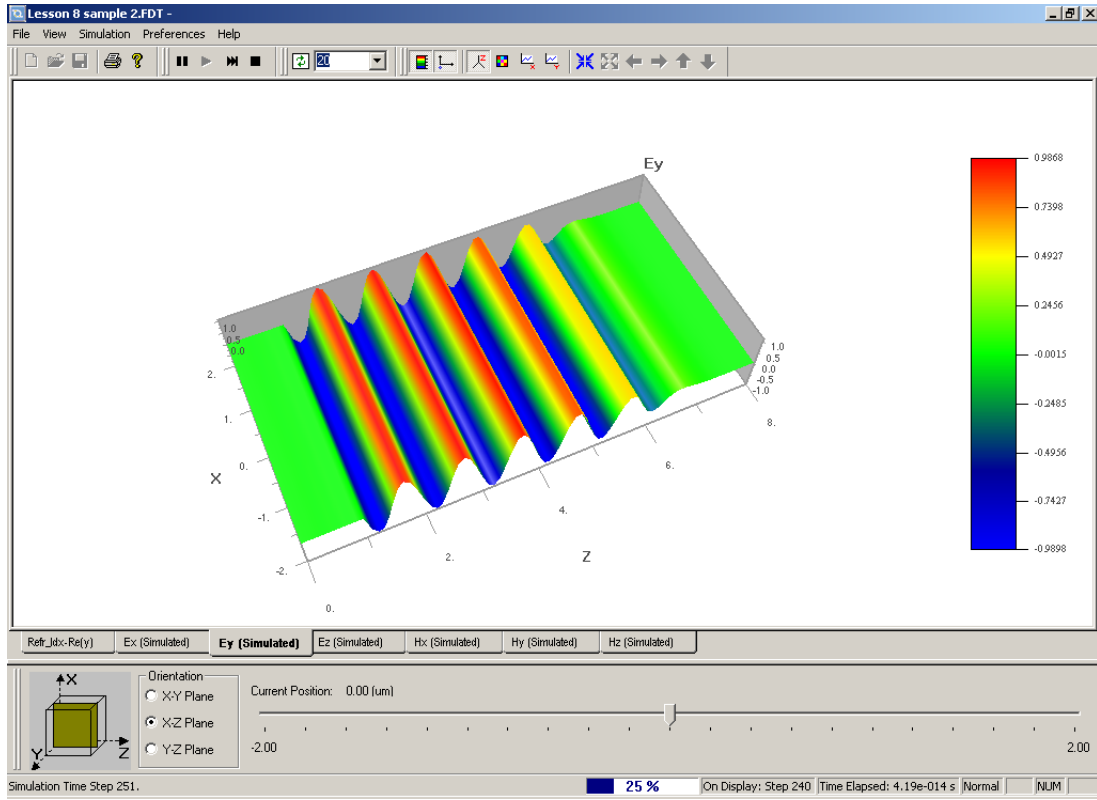
Setting the 3D-Y-direction polarized plane wave simulation parameters

- | Step | Action |
|------|--|
| 1 | From the Simulation menu, select 3D Simulation Parameters .
<i>The 3D Simulation Parameters dialog box appears.</i> |
| 2 | Type/select the following information:
Mesh Delta X [μm]: 0 . 1
Mesh Delta Y [μm]: 0 . 1
Mesh Delta Z [μm]: 0 . 1 |
| 3 | Click Advanced...
<i>The Boundary Conditions dialog box appears.</i>
-X: PMC
+X: PMC
-Y: PEC
+Y: PEC
-Z: Anisotropic PML
+Z: Anisotropic PML
Anisotropic PML Calculation Parameters
Number of Anisotropic PML Layers: 10
Theoretical Reflection Coefficient: 1 . 0e-12
Real Anisotropic PML Tensor Parameters: 1 . 0
Power of Grading Polynomial: 3 . 5 |
| 4 | Click OK .
<i>The Boundary Conditions dialog box closes.</i> |
| 5 | In Time Parameters, click Calculate .
<i>The default time step size is calculated.</i> |
| 6 | Select Run for 1000 Time Steps (Results Finalized) . |
| 7 | Select Key Input Information: Input Plane1 and waveLength: 2.00 . |
| 8 | Select DFT Options: Electric Components: Ey . |
| 9 | Click Run to start the OptiFDTD Simulator . |

When the simulation is running, the plane wave effect can be observed in the simulator (see [Figure 26](#)).



Figure 26 3D Y-direction polarized plane wave



Lesson 9—FDTD Band Solver

FDTD Band Solver in OptiFDTD is a supplementary tool for the Photonic Crystal (PhC) and Photonic Band Gap (PBG) structure. Currently it employs the FDTD method and generates what is called the Band Diagram. For the transmission and reflection analysis for PhC and PBG, it is still suggested to use the conventional FDTD method demonstrated in [Lesson 3—Photonic crystal and photonic band gap simulation](#), because the FDTD simulation for generating the band diagram is dependent on the initial condition, Bloch's periodic boundary condition, and sufficient monitor points. This means that there is no guarantee that all bands will be found. In future releases, we will update the PWE method, which will guarantee that all the necessary bands will be found.

To start the band solving, you need to define a photonic lattice structure in the layout window. If no photonic crystal lattice exists in the layout window, then the FDTD band solver is not active—the 2D band solver item in the simulation menu is disabled.

Photonic crystal structure

Creating a layout

- | Step | Action |
|------|--|
| 1 | Open the OptiFDTD Waveguide Layout Designer . |
| 2 | To create a new project, select File > New .
<i>The Initial Properties dialog box appears.</i> |
| 3 | Click Profiles and Materials .
<i>The Profile Designer window appears.</i> |
| 4 | Under the Materials folder, right-click the Dielectric folder and select New .
<i>A new Dielectric material dialog box appears.</i> |
| 5 | Type the following information:
Name: er=8.9
Refractive index (Re:): 2.983287 |
| 6 | Click Store . |



Defining the channel profile

- | Step | Action |
|-------------|--|
| 1 | Under the Profiles folder, right-click the Channel folder and select New .
<i>The ChannelPro1 dialog box appears.</i> |
| 2 | Create the following channel profile:
Profile name: Profile_PhC
2D profile definition
Material: er=8.9
3D profile definition
Layer name: layer_01
Width: 1.0
Thickness: 1.0
Offset: 0.0
Material: er=8.9 |
| 3 | Click Add . |
| 4 | Click Store . |
| 5 | Close the Profile Designer . |

Defining wafer and waveguide properties

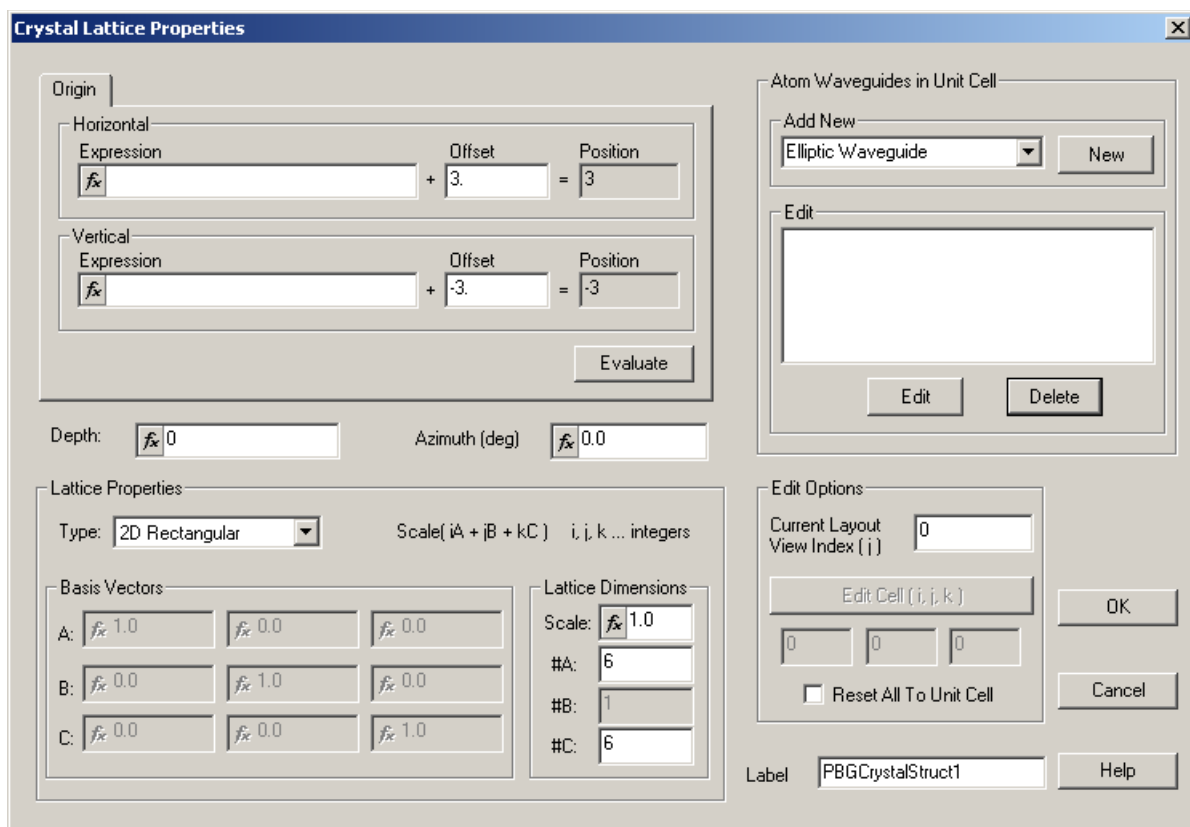
- | Step | Action |
|-------------|---|
| 1 | In the Initial Properties dialog box, type/select the following:
Waveguide Properties
Width [μm]: 1.0
Profile: Profile_PhC
Wafer Dimensions
Length [μm]: 10.0
Width [μm]: 10.0
2D Wafer Properties
Material: Air
3D Wafer Properties
Cladding
Thickness [μm]: 1.0
Material: Air
Substrate
Thickness [μm]: 1.0
Material: Air |
| 2 | Click OK .
<i>The Initial Properties dialog box closes.</i> |



Creating the PBG crystal structure

- | Step | Action |
|------|--|
| 1 | From the Draw menu, select PBG Crystal Structure . |
| 2 | Click in the layout window to create the PBG area.
<i>The PBG Crystal Structure appears in the layout window.</i> |
| 3 | Click on the Select tool. |
| 4 | To set the PBG properties, double-click on the PBG Crystal Structure in the layout.
<i>The Crystal Lattice Properties dialog box appears (see Figure 27).</i> |

Figure 27 Crystal Lattice Properties dialog box



- | | |
|---|--|
| 5 | In Origin, Offset , type/select the following:
Horizontal: 3 . 0
Vertical: -3 . 0 |
| 6 | Click Evaluate . |
| 7 | Type/select the following:
Depth: 0 . 0
Azimuth [deg]: 0 . 0 |



- 8 In **Lattice Properties**, select Type: **2D Rectangular**.
- 9 In **Lattice Dimensions**, type/select the following:
 - Scale: **1.0**
 - #A: **6**
 - #C: **6**
- 10 In **Label**, type **PBGCrystalStruct1**.

Note: Do **NOT** close the **Crystal Lattice Properties** dialog box.

Setting the atom properties

To set the atom properties, perform the following procedure in the **Crystal Lattice Properties** dialog box.

- | Step | Action |
|-------------|---|
| 1 | In Atom Waveguide in Unit Cell, Add New , select Elliptic Waveguide from the drop-down menu and click New .
<i>The Elliptic Waveguide Properties dialog box appears.</i> |
| 2 | In Center, Offset , type/select the following: <ul style="list-style-type: none"> Horizontal: 0.0 Vertical: 0.0 |
| 3 | Type/select the following: <ul style="list-style-type: none"> Major radius: 0.2 Minor radius: 0.2 Orientation Angle: 0.0 Channel Thickness Tapering: Use Default (Channel: None) Depth: 0.0 Label: Atom Profile: Profile_PhC. |
| 4 | Click OK .
<i>The Elliptic Waveguide Properties dialog box closes.</i> |
| | Note: When you return to the Crystal Lattice Properties dialog box, you will see the defined elliptic waveguide listed in Atom Waveguide in Unit Cell (see Figure 29). |
| 5 | Click OK in the Crystal Lattice Properties dialog box. |



Figure 28 Defined elliptic waveguide in Unit Cell Edit table

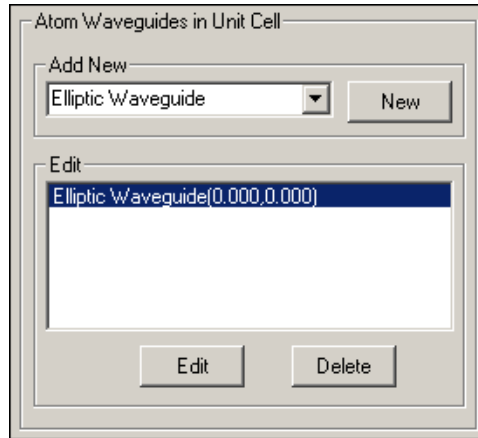
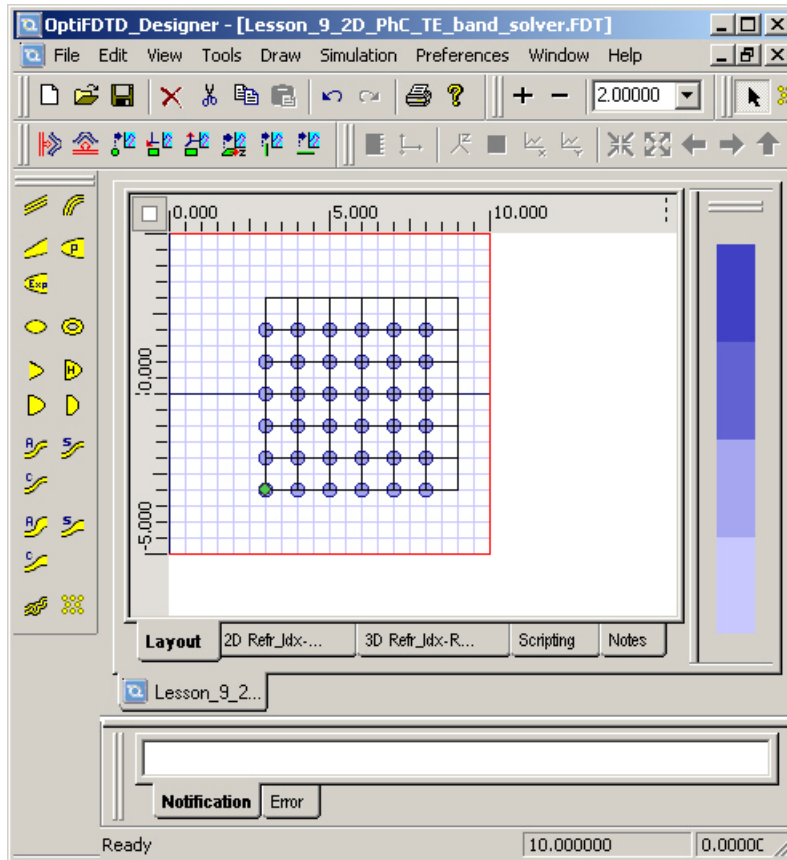


Figure 29 Defined PhC structure in layout



Band Solver parameters

When you open the **2D Band Solver Parameters** dialog box (from the layout designer **Simulation** menu), OptiFDTD automatically checks to see if the lattice structure exists in the layout. Available lattice structures are listed under **Domain**, in the **Lattice Name** drop-down list. Currently only 2D square lattice and 2D hexagonal lattice are supported.

The FDTD simulation takes one unit cell as the fundamental periodic cell. You can specify how many unit cells are to be used for the simulation under **Domain**. This is controlled by **Supercells #X** (in x -direction) and **#Z** (in z-direction). Usually a 1×1 cell (unit cell) is good enough for extracting the band diagram.

You can also specify the **TE** or **TM** wave under **Polarization**.

When you specify the supercell, you then need to set the mesh size for the FDTD simulation, in **Mesh**.

The FDTD simulation finds the eigen modes for one given K-vector. The K-vectors (a series value) are defined under **K-vector Path**. The **Division** number refers to how many K-vector sampling points there are for each sub-K-vector path. Please refer to the Technical Background to see how we set the default K-path.

The FDTD band solver calculation is controlled by four items, other than the mesh:

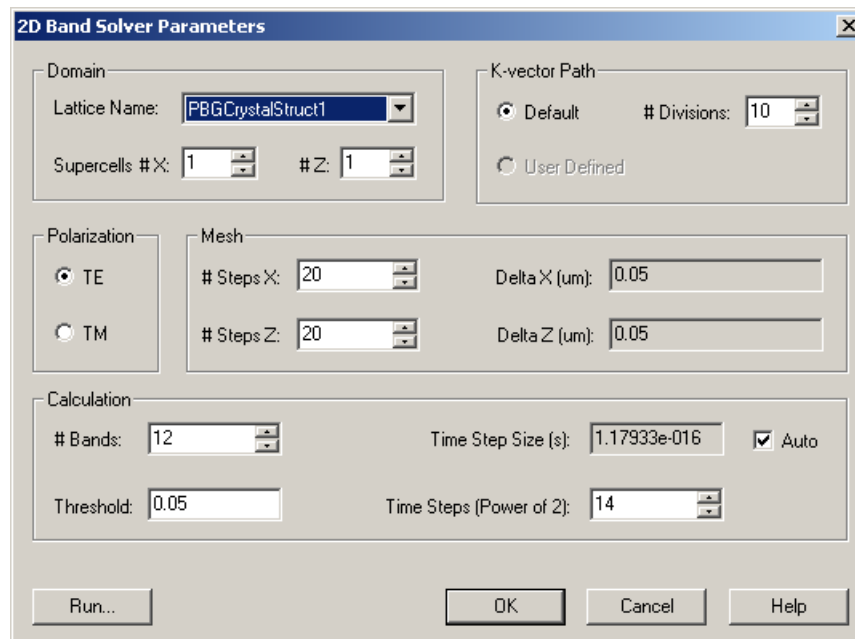
- **# Bands**—the number of modes extracted from the FDTD simulation.
- **Threshold**—the eigen value is obtained from the spectrum response which the peak value is normalized to unit. If sub-peak value is smaller than this threshold value, then the value is not regarded as a mode.
- **Time Step Size (s)**—domain size, time interval for FDTD simulation.
- **Time Steps (Power of 2)**—FFT is used to get the spectrum response. The FDTD simulation needs to run for 2N time steps to match the FFT requirement. So the value of N should be specified.



Setting the band solver simulation parameters

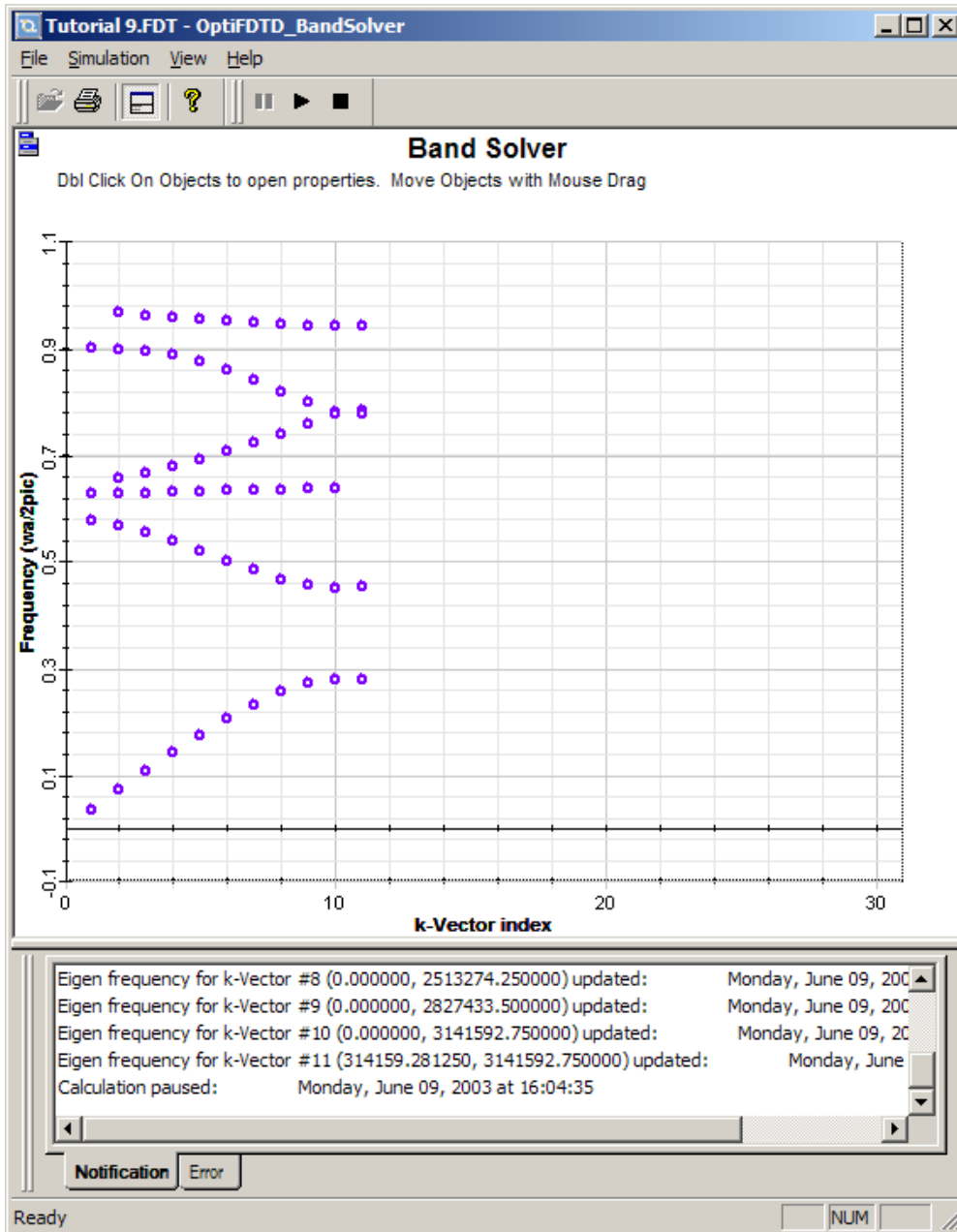
- | Step | Action |
|------|---|
| 1 | From the Simulation menu, select 2D Band Solver Parameters .
<i>The 2D Band Solver Parameters dialog box appears (see Figure 30).</i> |
| 2 | Type/select the following information:
Lattice Name: PBGCrystalStruct1
Supercells:
#X: 1
#Z: 1
K-vector Path:
Divisions: 10
Polarization: TE
Mesh:
Steps X: 20
Steps Z: 20
Calculation:
of Bands: 12
Threshold: 0.05
Time Step Size [s]: Auto
Time Steps [Power of 2]: 14 |
| 3 | Click Run to start the OptiFDTD_BandSolver (see Figure 31). |

Figure 30 2D Band Solver Parameters dialog box



The band diagram is updated instantaneously for each K-vector value. The corresponding K-vector value is shown in the output box at the bottom of the **OptiFDTD_BandSolver** dialog box.

Figure 31 OptiFDTD_BandSolver



When the simulation is finished, the results are saved to a file with a ***.bnd** extension.



Viewing the simulation results

- | Step | Action |
|-------------|--|
| 1 | In the OptiFDTD_BandSolver , select File > Load results .
<i>The Select 2D Band Solver Result File dialog box appears.</i> |
| 2 | Select the *.bnd file that you want to view and click Open .
<i>The results are displayed in the OptiFDTD_BandSolver dialog box.</i> |



Notes:



Lesson 10 - Lorentz_Drude model for metal and surface plasma simulation

OptiFDTD versions 2 through 4 provided a Drude model and a separate Lorentz model for metal, plasma and dispersive material simulation. The two models work only for 2-dimensional (2D) layouts. Based on feedback from our customers, OptiFDTD 5.0 introduced a combined model called the Lorentz-Drude model. This model can handle both the Drude and Lorentz dispersive effects and works for both 2D and 3D simulations.

The Lorentz-Drude model is intended for use with Noble Metals and Surface Plasma in the optical band. This new material model provides more accurate results than the older Drude model and Lorentz model.

Note: It is recommended that you read the section in the Technical Background describing the Lorentz-Drude model equation. OptiFDTD also provides a sample for this Lorentz- Drude model simulation. The following explanation uses this sample file as an example.

The corresponding layout file is available in the OptiFDTD set up CD:

Sample29_2D_TE_Lorentz_Drude_Model_Ag_Filter.FDT.

The corresponding results file is available on the OptiFDTD setup CD:

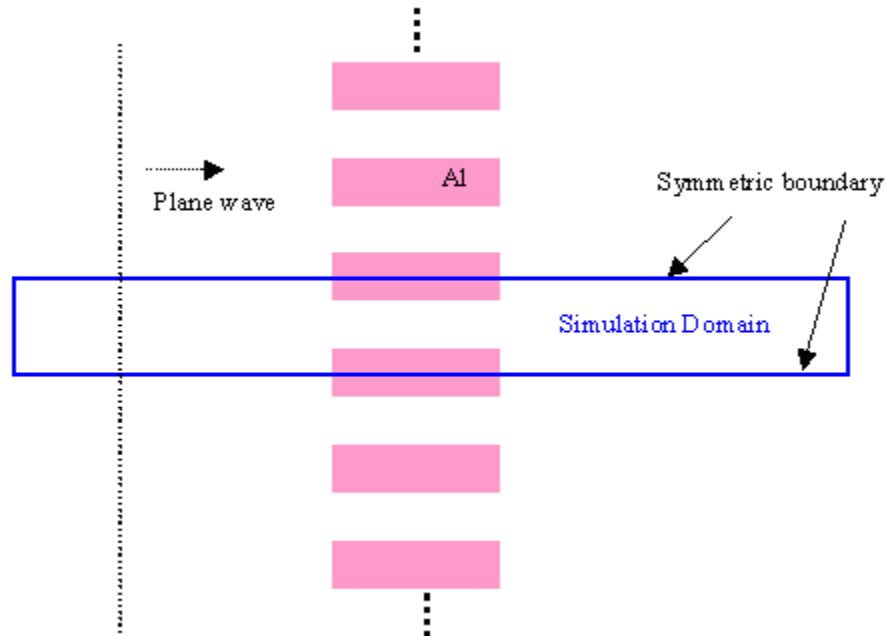
Sample29_2D_TE_Lorentz_Drude_Model_Ag_Filter.fda.

In this lesson we will use a 2D project to demonstrate the Lorentz-Drude model material definition and the corresponding simulation. A 3D project can use the same basic techniques described in this lesson, but using a 3D layout instead of a 2D layout.

The layout we are going to simulate is shown in [Figure 1](#). It is an aluminum-grating layout with air as the background material. Because the input wave is plane wave and it is a periodic structure, we can use just one periodic unit cell for the simulation. The step-by-step method for this is the basis of this tutorial.



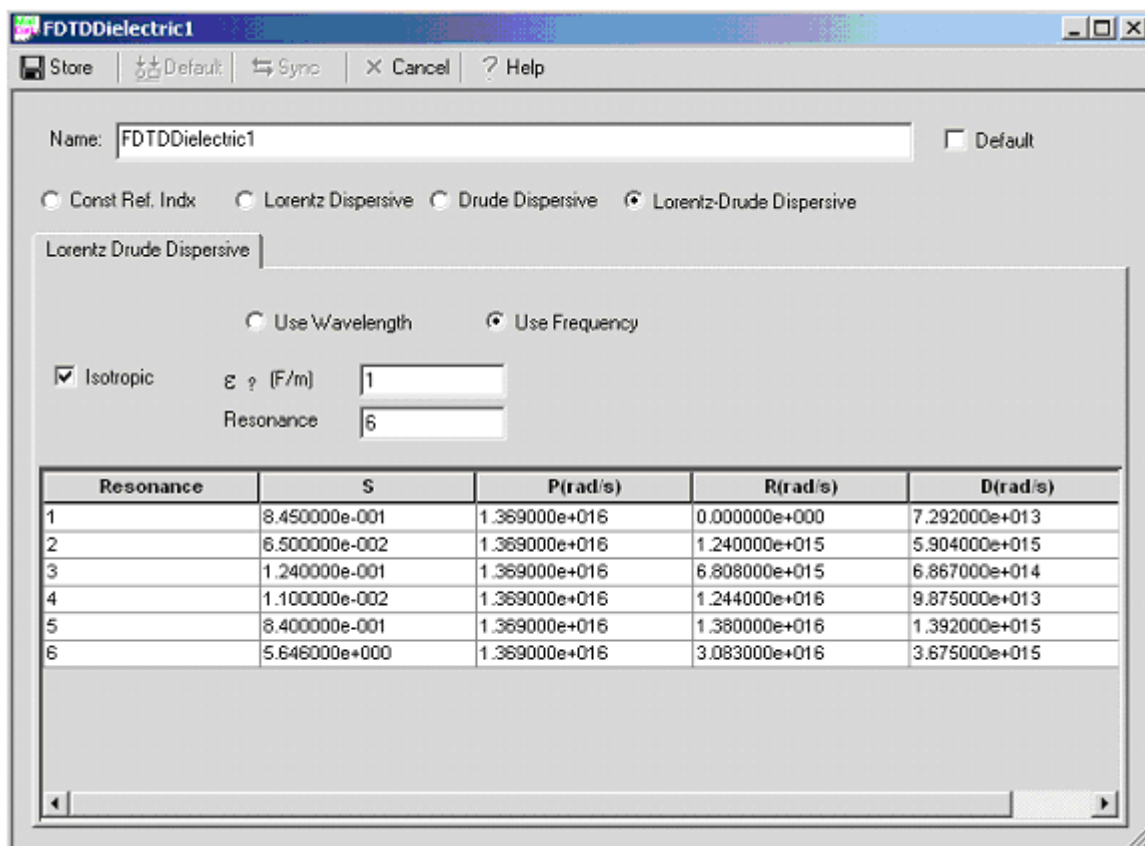
Figure 1 Design of the layout to be simulated



Creating a project with Lorentz-Drude material

- | Step | Action |
|------|--|
| 1 | Start Waveguide Layout Designer. |
| 2 | To create a new project, from the File menu, select New .
<i>The “Initial Properties” dialog box appears.</i> |
| 3 | Click the “ Profiles And Materials ” button.
<i>The Waveguide Profile Designer appears.</i> |
| 4 | In the directory under OptiFDTD_Designer1 of the Profile Designer, under the Materials folder, right-click the FDTD-Dispersive folder, and select New . The “ FDTDDielectric1 ” material definition dialog box appears. |
| 5 | In the “ FDTD Dielectric1 ” material definition dialog box, select “ Lorentz-Drude Dispersive ” option.
<i>The Lorentz-Drude material data-entry tab appears (see Figure 2).</i> |

Figure 2 Lorentz-Drude Dispersive Material dialog box



- 6 In the Lorentz-Drude material definition dialog box, define following parameters

Name: Lorentz_Drude_AI

Select: "User Frequency" radio button

Check: "Isotropic" checkbox

$\epsilon_{\infty} (F/m)$: 1.0

Resonance: 5

Resonance	S	P(rad/s)	R (rad/s)	D (rad/s)
1	0.523	2.2758e16	0.0	7.140e13
2	0.227	2.2758e16	2.461e14	5.059e14
3	0.050	2.2758e16	2.346e15	4.740e14
4	0.166	2.2758e16	2.747e15	2.053e15
5	0.030	2.2758e16	5.276e15	5.138e15



Where:

- | | |
|------------------|---|
| S | - Strength of the corresponding resonance terms |
| P (rad/s) | - Plasma frequency |
| R (rad/s) | - Resonant frequency |
| D (rad/s) | - Collision frequency (or damping factor) |

Note:

- Refer to the Technical Background description when you first start preparing metal simulations.
- Parameters of aluminum are located in the appendix of Technical Background

Enhancement

In the above parameter set up, if we only set one term, and set resonant frequency as zero, we will simulate a Drude model material

- 7 Click "**Store**" to save the defined material
*The "**Lorentz_Drude_AI**" will be listed in the FDTD-Dielectric folder of the Waveguide Profile Designer*
- 8 In the directory under "**OptiFDTD_Designer1**" Profile folder, right-click the "**Channel**" folder, and select **New**.
*The "**ChannelPro1**" will be created and its data entry dialog box will appear.*
- 9 In the "**ChannelPro1**" dialog box, set Profile Name to "**ChannelPro1_AI**" and 2D ProfileMaterial to "**Lorentz_Drude_AI**"
- 10 Save the profile.
- 11 Close the Profile designer

Designing the waveguides

Step Action

- 1 In the "Initial Properties" dialog box, set the following parameters:

Waveguide Properties

Width:	0.135 [mm]
Profile:	ChannelPro1_AI

Wafer dimension

Length:	1.0 [mm]
---------	-----------------



Width: **0.54 [mm]**

2D Wafer Material: **Air**

- 2 Click **OK** to start the Layout Designer.
The OptiFDTD designer window appears. Click Zoom (“+”) to enlarge the layout
- 3 From the **Draw** menu, select **Linear Waveguide**.
- 4 Draw the waveguide in the layout at desired the position.
The waveguide appears in the layout.
Note: Click the **Select** tool after drawing the waveguide.
- 5 Double click the waveguide to edit the waveguide position and properties.
*The **Linear Waveguide** properties dialog box appears.*
- 6 Set the following parameters:

Waveguide start position (offset)

Horizontal: **0.225**

Vertical: **0.2025**

Waveguide end position

Horizontal: **0.625**

Vertical: **0.2025**

Select “**Use Default**” checkbox for channel thickness tapering

Width: **0.135**

Depth: **0.0**

Profile: **ChannelPro1_AI**

- 7 Design another linear waveguide with following parameters:

Waveguide start position (offset)

Horizontal: **0.225**

Vertical: **-0.2025**

Waveguide end position

Horizontal: **0.625**

Vertical: **-0.2025**

Select “**Use Default**” checkbox for channel thickness tapering.

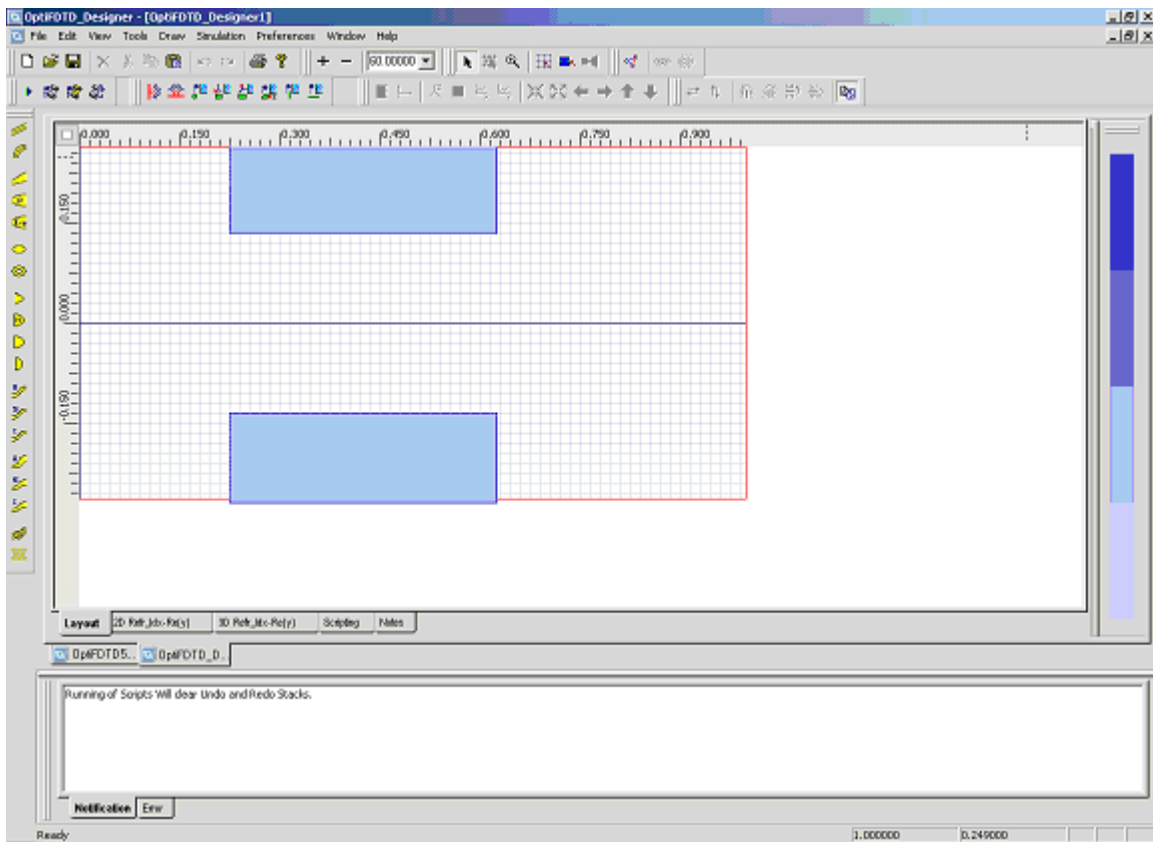
Width: **0.135**

Depth: **0.0**

Profile: **ChannelPro1_AI**

The layout will look as presented in [Figure 2](#).

Figure 3 Waveguide in the layout



Setting the Input Plane

- | Step | Action |
|------|---|
| 1 | From the Draw menu, select Vertical Input Plane . |
| 2 | Insert the Input Plane into the layout at the desired position.
<i>A red line representing the input plane appears in the layout window.</i> |
| 3 | Double-click the Input Plane.
<i>The "Input Field Properties" dialog box appears.</i> |



- 4 Select **Gaussian Modulated Continuous Wave** radio button
- 5 Set the center wavelength to **0.55um**.
- 6 Click **Gaussian Modulated CW** button, and set the following parameters

Time offset (sec):	1.0e-14
Half Width (sec):	1.0e-15

Note: This step set the time domain input as pulse

- 7 Click the **General** tab, and then click **Rectangular** radio button.
- 8 Click the **2D Transverse** tab to Set the plane wave properties

Center Position:	0.0
Half Width:	0.27
Tilting Angle:	0.0
Effective Refractive Index:	Local
Input Amplitude or Power:	1.0
- 9 Click the **General** tab, set **Plane Geometry Position** to **0.125** and select **Positive direction**.
- 10 Click **OK** to close the input plane properties dialog box

Setting the observation line

The observation line is only used for 2D simulations. It is used to show

- Field distribution along the line for the user input wavelength
- Calculate the outgoing power in the line for user input wavelength
- Calculate the absolute power spectrum and normalized transmittance power spectrum (to the input power)

Step Action

- 1 From the **Draw** menu, select **Observation Vertical Line**.
- 2 Place the **Observation Line** in the desired position in the layout.
- 3 Double-click the observation line.
- 4 The **Observation Properties -- Vertical Line** dialog box appears.
- 5 The **General** tab settings:
- 6 In **Center**, **Offset**, type (select) the following:

Horizontal:	0.9 mm
-------------	---------------

Vertical: **0.0 mm**
 X length: **0.54mm**
 Label: **ObservationLine1**

- 7 On the “**Data Components**” tab, select the following:
 2D TE: **Ey, Hx, Hz**
- 8 Click **OK**.

Setting up 2D Simulation parameters

- | Step | Action |
|-------------|---|
| 1 | From the Simulation menu, select 2D Simulation Parameters .
<i>The “Simulation Parameters” dialog box appears</i> |
| 2 | Select TE polarization option. |
| 3 | Set x-direction mesh and z-direction mesh to 0.005 . |
| 4 | Click Advanced . |
| 5 | Set the Anisotropic PML boundary condition parameters:
+x: PMC
-x: PMC
+z: Anisotropic PML
-z: Anisotropic PML

Number of Anisotropic PML layers: 25
Theoretical Reflection Coefficient: 1.0e-12
Real Anisotropic PML Tensor Parameter: 5.0
Power of Grading Polynomial: 3.5 |

Note: The x- edge is set as PMC because we perform the simulations on a periodic cell and use the plane wave excitation. It works like a symmetric boundary. Please refer to the Technical Background for Plane wave simulation

- 6 Click **Calculate** to get the Time Step Size.
- 7 Set **Run** for **6000** time steps for finalization.
- 8 From the “**Key Input Plane**” drop-down list, select “**Input Plane1**” and “**Wavelength**” equal to **0.55**

Note: The Key Input Plane's Center Wavelength will be used for the DFT calculation.

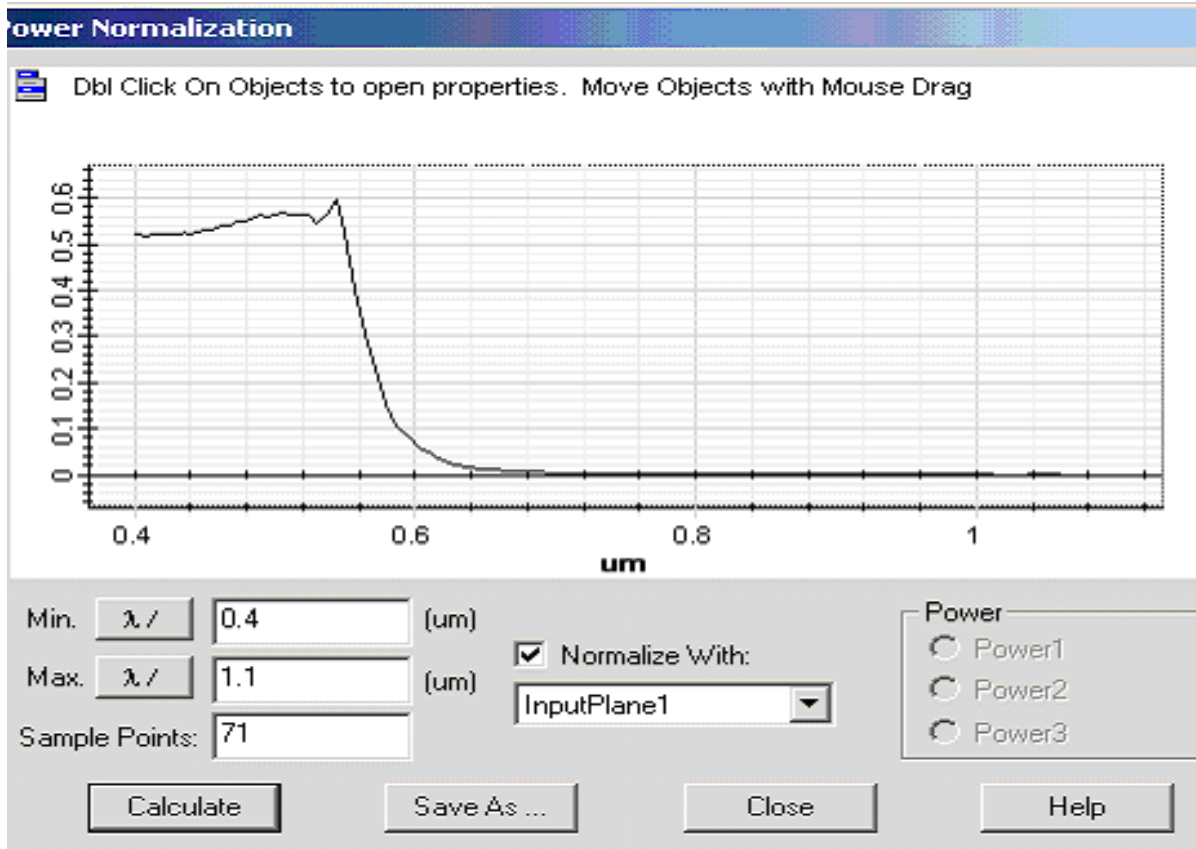
- 9 Click **OK** to close the **Simulation Parameters** dialog box without running the simulation, or click **Run** to start the **OptiFDTD Simulator**.



Performing the simulation

When the Simulator starts, the propagation field can be observed as presented in Figure 4.

Figure 4 Dynamic field pattern in OptiFDTD simulator



Performing data analysis

After the simulations are completed, you can open the analyzer to do the post-simulation analysis. The tools for post-processing data analysis are already discussed in other lessons. In this lesson we will demonstrate usage of an observation line to extract the transmittance.

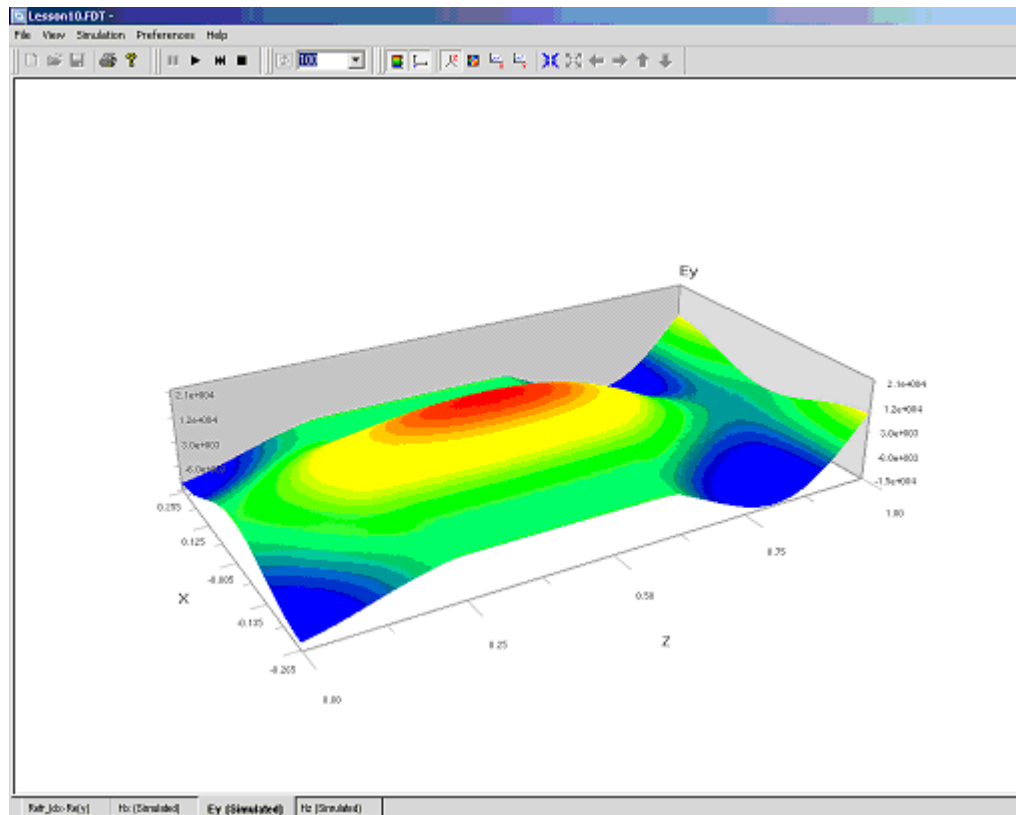
Step Action

- 1 In the OptiFDTD analyzer, select **Observation Area Analysis** in the tools menu
- 2 Click Observation Line button. Observation line page appears.
This page can show the field pattern in observation line for user specified wavelength
- 3 Click "**Power Spectrum**" button, and set the following parameters to extract the power transmittance.

Minimum wavelength:	0.4 [mm]
Maximum wavelength:	1.1 [mm]
Sample point:	71
Normalized with:	Input Plane1
- 4 Click "**Calculate**" button to start transmittance calculation. The results will be shown in the graph. (see [Figure 5](#))

Note: It will take a while for this calculation to complete, because DFT is calculated for each field component of each point in the line

Figure 5 Power normalization (Transmittance)



Discussion:

- This lesson utilizes 2D layout to demonstrate usage of Lorentz-Drude materials in OptiFDTD simulations.
- Materials in this layout can be switched to perfect conductor or other metals to observe their interaction with the optical field
- 3D simulation for Lorentz-Drude material has the same concept as 2D simulation. However, if Lorentz-Drude material in 3D layout touches the boundary, the corresponding Anisotropic PML will use the air instead. This approach has been chosen, since calculations for Lorentz-Drude material in Anisotropic PML consume too much time and memory.
- Lorentz-Drude material needs very fine mesh. In general the mesh size should be at least 2 percent of the smallest simulated wavelength. A large mesh size will render the FDTD method algorithm unstable. The FDTD scheme for coarse mesh is unable to properly represent quick changes in signal attenuation within a few mesh points.

NOTES:

LESSON 10 - LORENTZ_DRUDE MODEL FOR METAL AND SURFACE PLASMA SIMULATION



Lesson 11 - Analyzing 1D Photonic Crystals (Bragg gratings)

Introduction

The simplest photonic crystal consists of alternating layers of material with different dielectric constants. Such multilayer structures have been widely studied and are frequently referred to as Bragg gratings.

In this tutorial we design simple Bragg Grating that consists of alternating layers with permittivity contrast 1/13 as discussed and analyzed in [1]. We will show how to use PWE band solver to analyze cases of both normal and oblique incidence, while pointing out other features of the software, namely output normalization and inversion symmetry.

The tutorial is structured as follows

- 1 [Define the Lattice Structure](#)
- 2 [PWE Band Solver Parameters](#)
- 3 [Run Simulation and View Results](#)
- 4 [Bragg grating with layers of different width](#)
- 5 [Off-axis propagation](#)

Define the Lattice Structure

Note:

- For the details on how a lattice can be created, please refer to [Lesson 3—Photonic crystal and photonic band gap simulation](#) and [Lesson 9—FDTD Band Solver](#).
- For the details on how material and waveguide profile can be created, please refer to Lessons 1 through to Lesson 9.

We start investigating system of equally thick alternating layers with dielectric constants $\epsilon_1=13$ and later on we will change layer thickness ratio. Open a new project. Create new materials named 'eps13' with constant isotropic refractive index of 3.6056. Material "Air" is a default material in OptiFDTD and will be used in this project. Here we use the relationship between refractive index and permittivity $\epsilon = n^2$. We will also need a channel profile with permittivity eps13. Create a new channel profile named 'chan_eps13' and specify its 2D refractive index as eps13. In this tutorial we will not use 3D profile definition.



It is a good practice to parameterize the layout design so that later modifications can be done in a fast and flexible way. We will first create several variables, which will represent some of the physical properties of the design.

Table 1:

lngh	10	Layout length
wdth	10	Layout width
offset	0.0	Horizontal offset of the unit cell elements from the lattice point (important in case of exploiting inversion symmetry).
scale	1.0	Scale factor - scales grating dimensions.
a	0.5	a will define width of a Bragg layer (c is lattice vector).

Note: To define the variable, please input the variable name in the **Initial Properties** dialog box. Click OK to access the **Variables and Function** dialog box to define the values.

Finish the initial steps by defining wafer, cladding and default waveguides as follows:

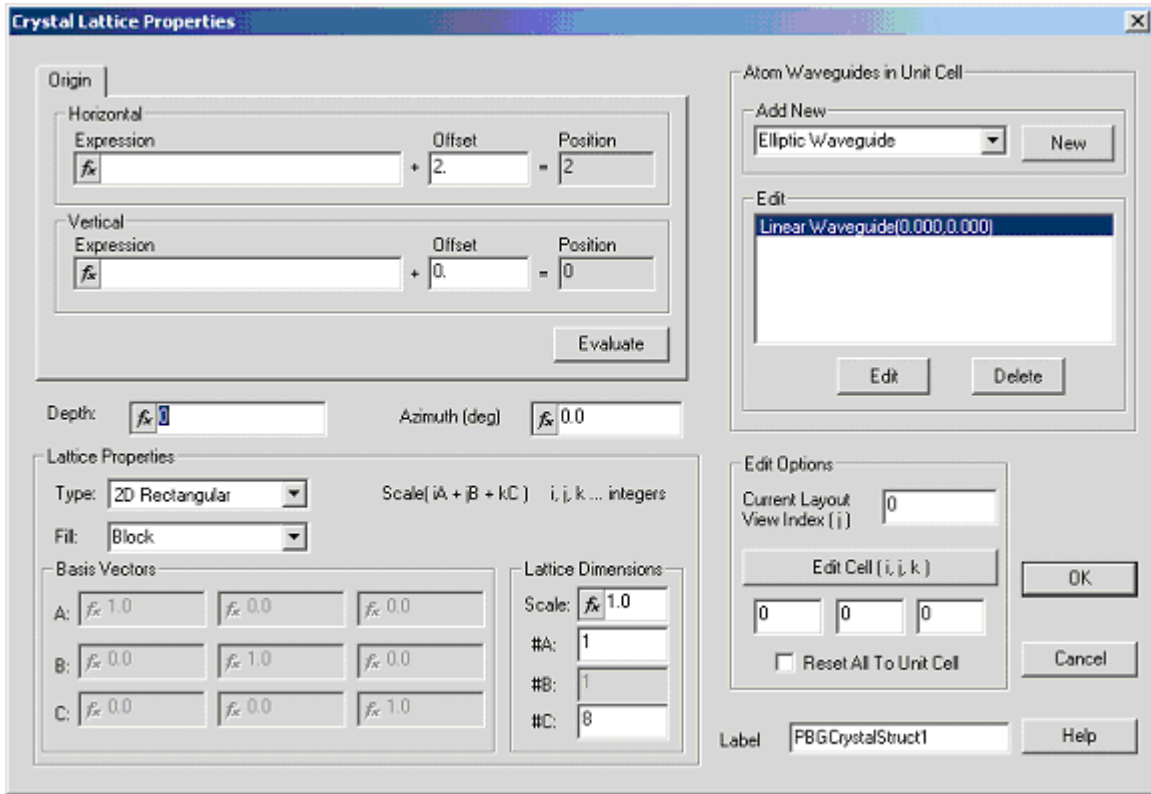
- Default profile: chan_eps13
- Waveguide width: *wdth*
- Wafer dimensions: *lngh* / *wdth*
- 2D Wafer: Air

Save the project under a new name.

There are several ways how to create a Bragg grating structure. You can create the structure by placing individual waveguides on the layout one by one, using script or lattice generator. We use the lattice generator to create 1D lattice with alternating layers represented by simple linear waveguides surrounded by air.

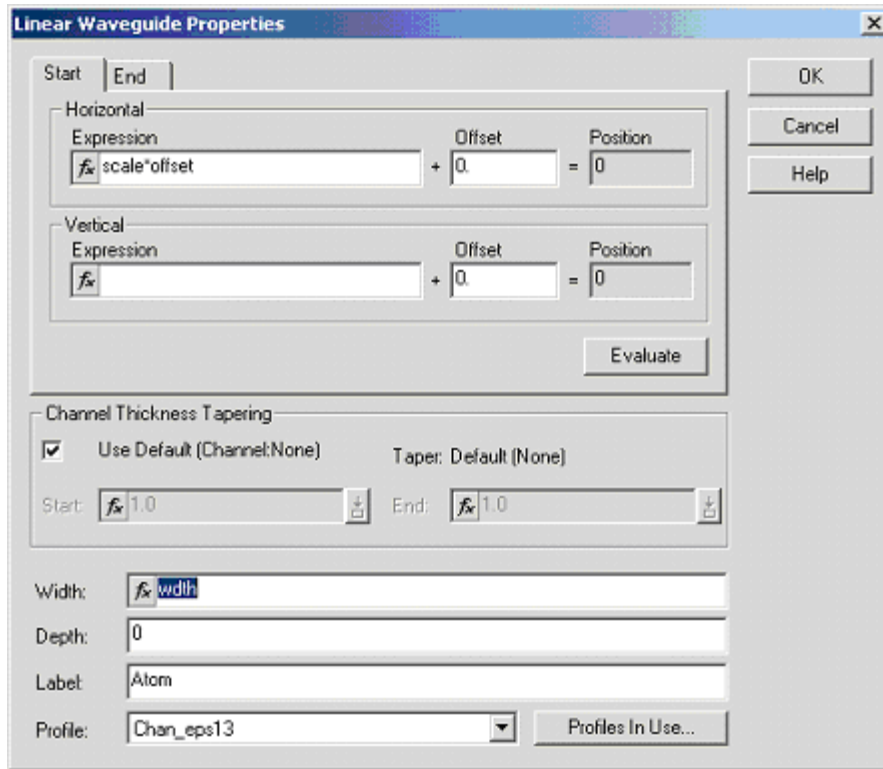
In the layout designer create a new PBG Crystal structure, double click on it to open the Crystal Lattice Properties dialog box. Use the default 2D rectangular lattice and specify the Lattice dimensions #A=1 and #C=8. This will create 1D lattice with 8 unit cells along C vector direction. Center the lattice on the layout by setting the origin as (2, 0) (horizontal, vertical). See [Figure 1](#)

Figure 1 Crystal lattice Properties dialog box



Add new linear waveguide atom to the unit cell. Now you need to edit the properties of the linear waveguide. As the atom uses absolute coordinates we have to use our scale variable to preserve scalability of the design. Set the linear waveguide position. (See [Figure 2](#))

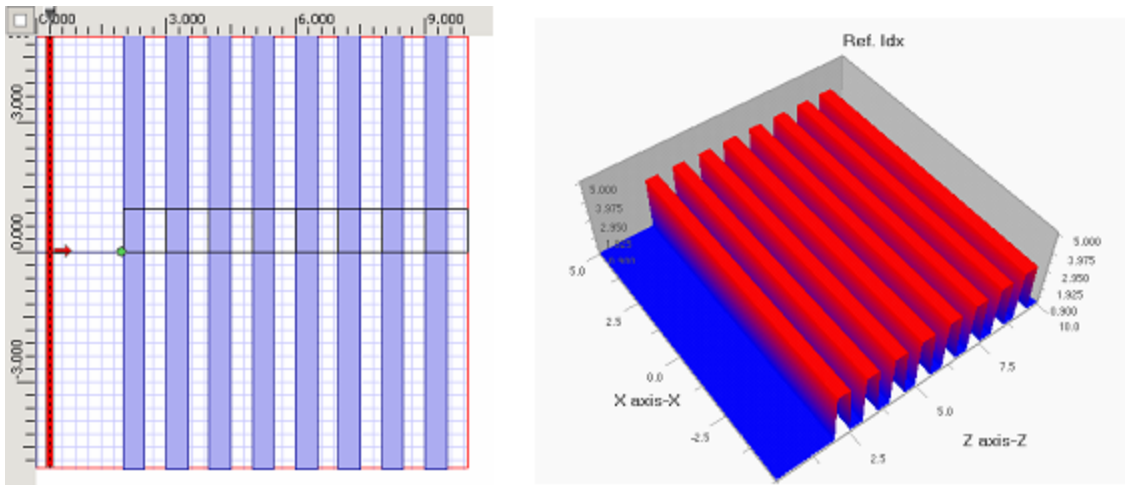
Figure 2 Atom---Linear Waveguide Properties Dialog box



- Start horizontal: $scale * offset$
- Start vertical: 0.0
- End horizontal: $scale * (offset + a)$
- End vertical: 0.0

Select chan_eps13 profile. Get back to the layout designer. Put vertical input plane in the z-position of 1.0um. Check the layout and refractive index visually. Persuade yourself that the design will scale when you change the scale factor *scale*. You can also experiment with the filling factor *a*. To view the refractive index you need to enter an input plane to the design.

Figure 3 Layout design (left) and refractive index view (right)

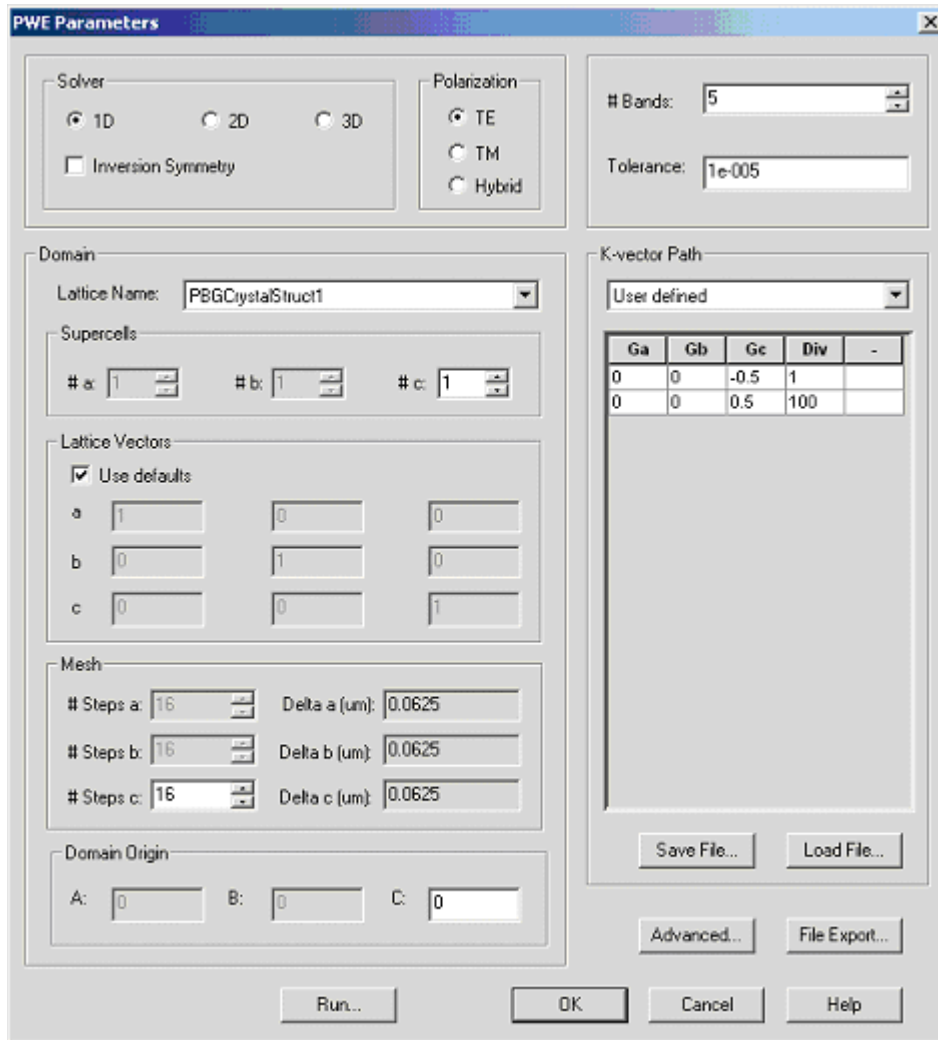


When you are finished experimenting make sure that $a=0.5$ and $scale=1.0$. To get final band diagrams in the same form as in the [1] we chose the lattice constant to be 1.

PWE Band Solver Parameters

Open PWE Parameters dialog box (Simulation->PWE Band Solver Parameters...)

Figure 4 PWE parameters dialog box



Unless stated otherwise use default values. In the Solver group select **1D, TE Polarization**. Domain parameter group gives you the option to modify the lattice vectors, mesh size as well as simulation center. Select **Use defaults** in 'Lattice Vectors' group. The band solver in 1D assumes a periodicity in z-direction; only the z-component of **c** vector can be changed. In solver 1D option the periodicity lattice vector is (0,0,z) where z-can be define by user or is setup as z-projection of the lattice vector **C**. Band solver automatically sets **a** and **b** vectors to (1,0,0) and (0,1,0) automatically. Notice that using defaults for the lattice vector you are not allowed editing them unless you uncheck the default check box.

In the Mesh group increase the number of **#Steps c** to 64 and leave the domain origin set to defaults, i.e. (0,0,0). Domain origin is the origin of the numerical domain expressed in terms of the lattice vectors A, B, and C.

$$Origin = O_{lattice} + A\bar{A} + B\bar{B} + C\bar{C}$$

By default the domain origin coincides with the origin of the lattice.

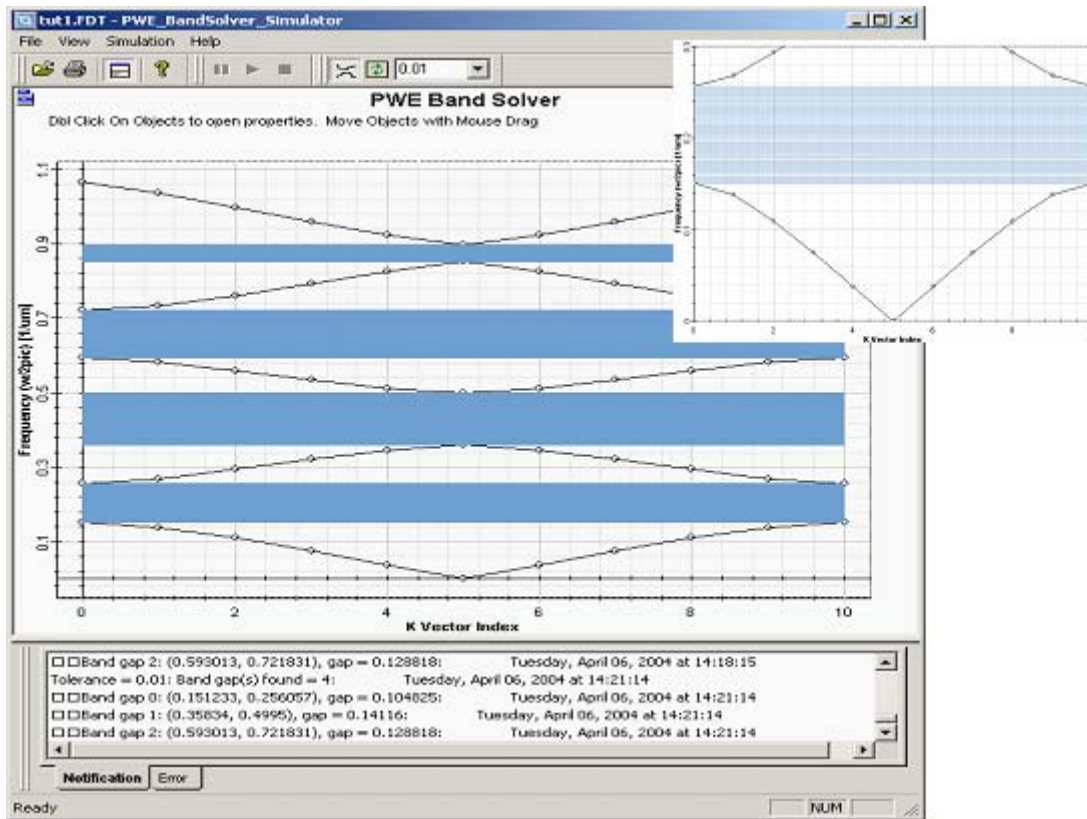
To perform band calculations we need to have a defined K-vector path. By default the k-path is not specified. Select **User defined** from pull-down menu in the 'K-vector Path' group. Add two new major k-vectors by right clicking on the k-path table and selecting 'Add' twice. Edit the vectors so that they lie on the opposite boundaries of the 1D Brillouin zone. As the k-path is specified in terms of reciprocal lattice vectors, the two vectors are (0,0,-0.5) and (0,0,0.5). Number of division determines overall number of the k-vectors along the path. The first vector has number of division automatically set up to 1, since there is no vector in the k-path preceding it. Set number of division next to the second major vector to 10 to generate path containing 11 k-vectors.



Run Simulation and View Results

When finished with editing band solver parameters click **Run...** to start the simulations. A simulation window will be launched and simulation starts. You will be notified in the in the output window at the bottom (Notification tab) about progress of the simulations. After the simulation is finished the graph is populated with set of eigenfrequencies of individual k-vectors. By default no processing is applied to the output data and the normalized frequencies are displayed as an unconnected set of points.

Figure 5 Band structure of the Bragg grating with layers of equal thickness 0.5mm (permittivity 13.0/1.0)

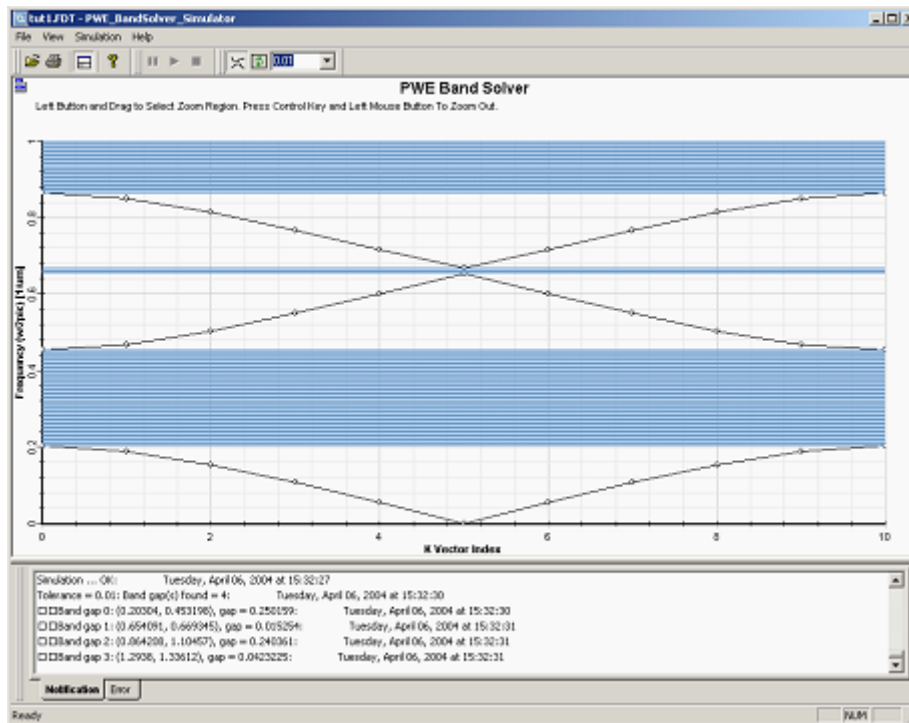


Use the **Connect** button on the Diagram toolbar to connect the eigenfrequencies of individual bands to get clearer picture of the band diagram. On occasions the current version of the engine will calculate the eigenvalues not in an exact order, in which case the connect button will produce incorrect band diagram. You can zoom on the diagram by right clicking and selecting the zoom tool. To identify the band gaps, if present, use the Locate band gaps button on the Diagram toolbar. It is possible to set a tolerance for the bandgaps detection in the adjacent input field. By default the tolerance is set to 0.01. Setting a high tolerance you can get rid of the highlighted band gaps.

Bragg grating with layers of different width

Thanks to the parameterized design we can easily verify other published results as well as point out other features of PWE band solver. Let's change a variable to 0.2 to simulate grating with alternating layers of different widths. The layer of the high permittivity (waveguides) will be 0.2a thick, whereas the air layer will be 0.8a thick (for $scale=1$). Below you see the resulting band structure as reported in reference [1].

Figure 6 Band structure of the Bragg grating with dielectric layers of thickness 0.2 mm (period =1mm, permittivity 13.0/1.0).



The calculated eigenfrequencies are plotted in a normalized fashion as,

$$frequency = \frac{\omega}{2\pi c}$$

in units [1/mm], which is not the same as usually reported results in a non-dimensional form ($\frac{\omega a}{2\pi c}$). To get the non-dimensional results, you need to scale the results by a

lattice constant in microns. As we have chosen the lattice constant to be $scale * |c| = 1.0 \mu\text{m}$, our results look the same as published ones. Let's now scale the design so that the lattice constant is equal to $2 \mu\text{m}$ by setting the variable *scale* to 2.0. Run the simulation again, detect the band gaps and compare the values. The first gap is now (0.1604, 0.3068) compared to the original (0.203, 0.453). The normalized frequency can be readily transform into a wavelength in microns as

$$\lambda = \frac{1}{frequency}$$

which means that the first band in our original simulation lies between 3.898 and 6.631 microns.

Off-axis propagation

In the previous examples we intentionally selected propagation direction (k-vector) normal to the multilayer structures. Changing the polarization from TE to TM we are getting the same results, which confirm that the TE/TM modes are degenerate. In case of an off-axis propagation the k-vector has a component parallel to the Bragg layers, and the degeneracy of TM/TE modes is lifted. The band solver allows you to investigate cases of off-axis incidence. This can be achieved by an appropriate k-path definition. We will be considering propagation along \mathbf{G}_2 reciprocal lattice vector, i.e. $k=(0, k_2, 0)$. As the ordering of the lattice vectors in the band solver is $(\mathbf{c}, \mathbf{a}, \mathbf{b})$ due to the layout designer \mathbf{G}_2 vector in this sample will correspond to x-direction (see 2D FDTD Band Solver).

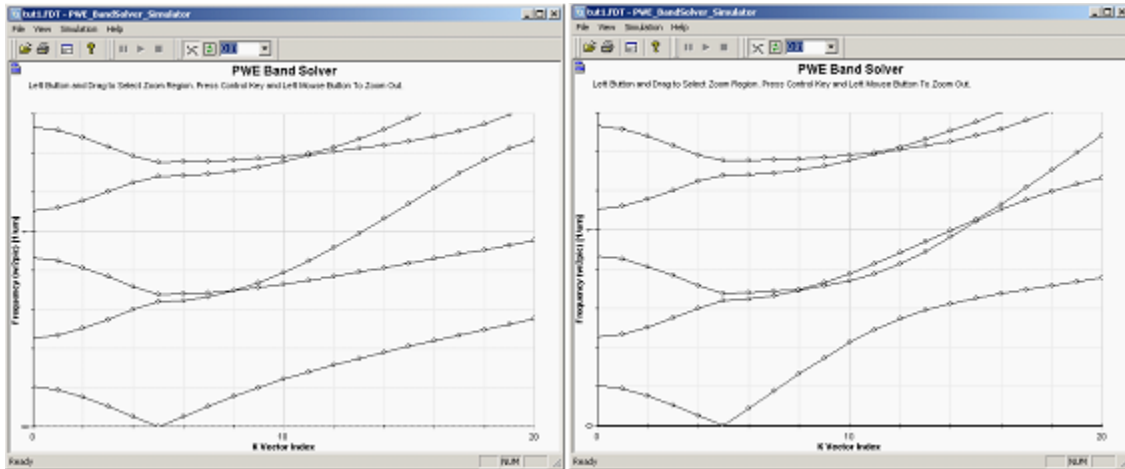
First save the current k-path in a file so that you can easily reload the path again later on. Click on '**Save File**' and in the 'SaveAs' dialog box input the name, e.g. BraggZ. Next redefine the k-path by adding one more major k-point and editing the k-path in the following manner:

- $k_1=(0.0, 0.0, -0.5)$, div=1
- $k_2=(0.0, 0.0, 0.0)$, div=5
- $k_3=(0.0, 1.5, 0.0)$, div=15

Thus the first part of the k-path from k_1 to k_2 will be the same as in the previous simulations but path from k_2 to k_3 will refer to propagation in y-direction (direction of the \mathbf{G}_2 reciprocal vector), parallel to the dielectric layers. The results of the simulations run for TE and TM polarizations are shown below.



Figure 7 Band structure of the Bragg grating for TE (left) and TM (right) polarizations. The first part of each diagram (indices 0-5) depicts on-axis propagation, where the TE and TM modes are degenerate (the same diagram) and band gaps are present. The right part of the diagrams (k-vector indices 5-20) shows lift of degeneracy and splitting of the TE/TM bands.



TE/TM solutions can also be described in the fashion of reference [1] as solutions with electric field vector in x-direction in case of TE and electric in yz plane in case of TM.

References:

- [1] Joannopoulos, J.D., Meade, R.D., Winn, J.N., "Photonic Crystals, Molding the flow of light", Princeton University Press 1995

LESSON 11 - ANALYZING 1D PHOTONIC CRYSTALS (BRAGG GRATINGS)

Lesson 12 - Analyzing 2D Photonic Crystals

Introduction

The tutorial demonstrates analysis of 2D photonic crystal using PWE Band solver. First we create a lattice model of dielectric cylinders (permittivity=8.9) suspended in air. We then proceed with a simple simulation on a predefined k-vector path and result analysis. Finally we discuss the meaning of the Domain Origin in the PWE dialog box.

Step	Action
1	Create layout of the 2D rectangular photonic crystal lattice
2	Set Parameters of PWE Band Solver
3	Simulation Run and Results Analysis
4	Using Inversion Symmetry and Domain Origin
5	2D Hexagonal lattice
6	Band solving of rotated lattices

1. Create a 2D rectangular lattice of dielectric cylinders

Note:

- For the details on how a lattice can be created, please refer to [Lesson 3—Photonic crystal and photonic band gap simulation](#) and [Lesson 9—FDTD Band Solver](#).
- For the details on how material and waveguide profile can be created, please refer to lesson 1 to lesson 9
- To define the variable, please input the variable name in the **Initial Properties** dialog box. Click “OK” to access the **Variables and Function** dialog box to define the values.

We are going analyze 2D photonic crystals with rectangular and hexagonal lattices as reported in reference [1]. Start defining necessary materials and channel profiles in the Profile Designer. Two tables below show the materials and channels needed for the project, next to proposed names and lattice, in which they are used. For the following exercise we will employ only 2D materials and channels.



Table 1

Material Name	2D Permittivity/refractive index [-]	Used in
eps8_9	8.9 /2.983287	2D rectangular lattice
eps1_0	1.0 /1.0	2D rectangular & hexagonal lattice
eps13_0	13.0 /3.605551	2D hexagonal lattice

Table 2

Channel Name	2D Material [-]	Used in
Chan_eps8_9	eps8_9	2d rectangular lattice
Chan_eps1	eps1_0	2D hexagonal lattice

After creating the materials and channels specify the dimensions of the wafer as 10x10microns and wafer material as eps1_0 (air). Create a 2D rectangular lattice of dielectric cylinders with permittivity 8.9 suspended in air, with radius of $0.2a$ where a is the lattice constant of the square lattice.

On the waveguide toolbar select the **PBG Crystal Structure** and click on the layout. Open the lattice properties by double clicking on the empty lattice structure. In the **Crystal Lattice Properties** dialog box set the Origin as (1,-4), in Lattice Properties select Type as 2D Rectangular and set both **#A** and **#C** to 8. We will build the lattice parameterized so that it is easy to change physical dimensions later on. Define a variable called 'a' and set it to 1. It will be our lattice constant. You can do so either from the **Crystal Lattice Properties** box by clicking any field which contains **fx** symbol or from the designer (Simulation >> Edit Parameters). As the basis vectors are in unit length by default, by setting Scale in Lattice Dimensions group to 'a' the lattice constant of the lattice is expressed by scale in microns.

In 'Atom Waveguides in Unit Cells' group add new elliptical waveguide with major and minor radius set to $0.2a$ and profile 'Chan8_9'. Now the lattice is defined.

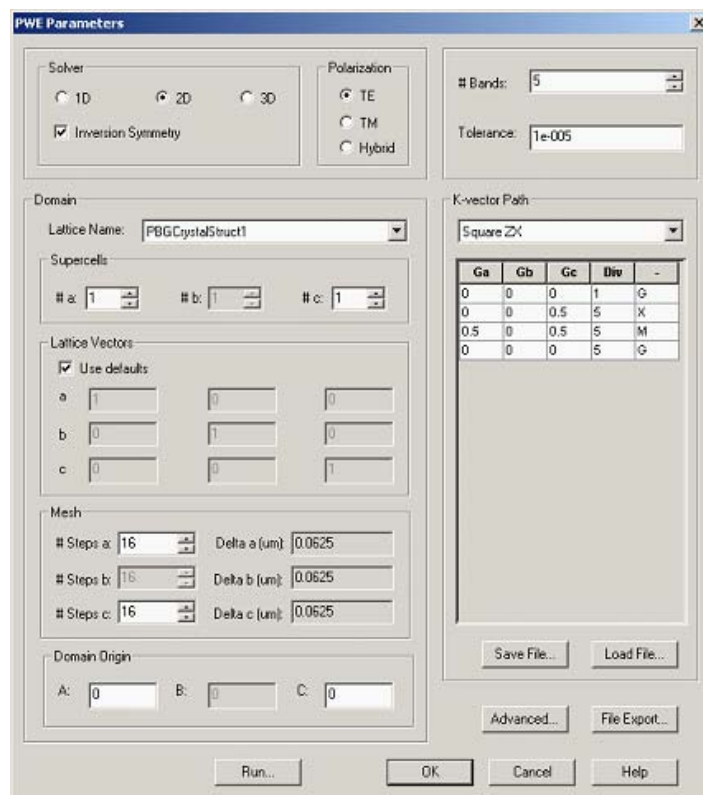
To test the parametrized lattice go to '**Simulation->Edit Parameters...**' and change 'a' variable value to e.g. 1.5, click ok and you will see that the whole lattice has the lattice constant of 1.5, and cylinders have radius of $0.2a$. Set scale to its original value 1.0.

2. PWE Band Solver Parameters

Open PWE Parameters dialog box (Simulation->PWE Band Solver Parameters...). By default the PWE solver should be set to 2D Solver, TE polarization, no inversion symmetry. The Lattice vectors should use defaults, i.e. the mesh (#Steps a, #Steps c) should be set to 16x16. Also make sure the Domain origin is set to (0,0,0). Set number of bands to 6 and tolerance to 10^{-6} for best results.

Now you have to define only the k-vector path. In case of a square 2D lattice with atoms having at least the same symmetry as the lattice you can use the predefined SquareZX path from the pull down menu in 'K-vector Path' group. This is a standard Reducible Brillouin zone of a square lattice as shown in technical background. The default path, defined in terms of reciprocal lattice vectors, automatically populates the K-vector path table. The path is defined by set of major k-points and associated number of division along the path from one major vector to another

Figure 1 PWE Band Solver Parameters Dialog Box

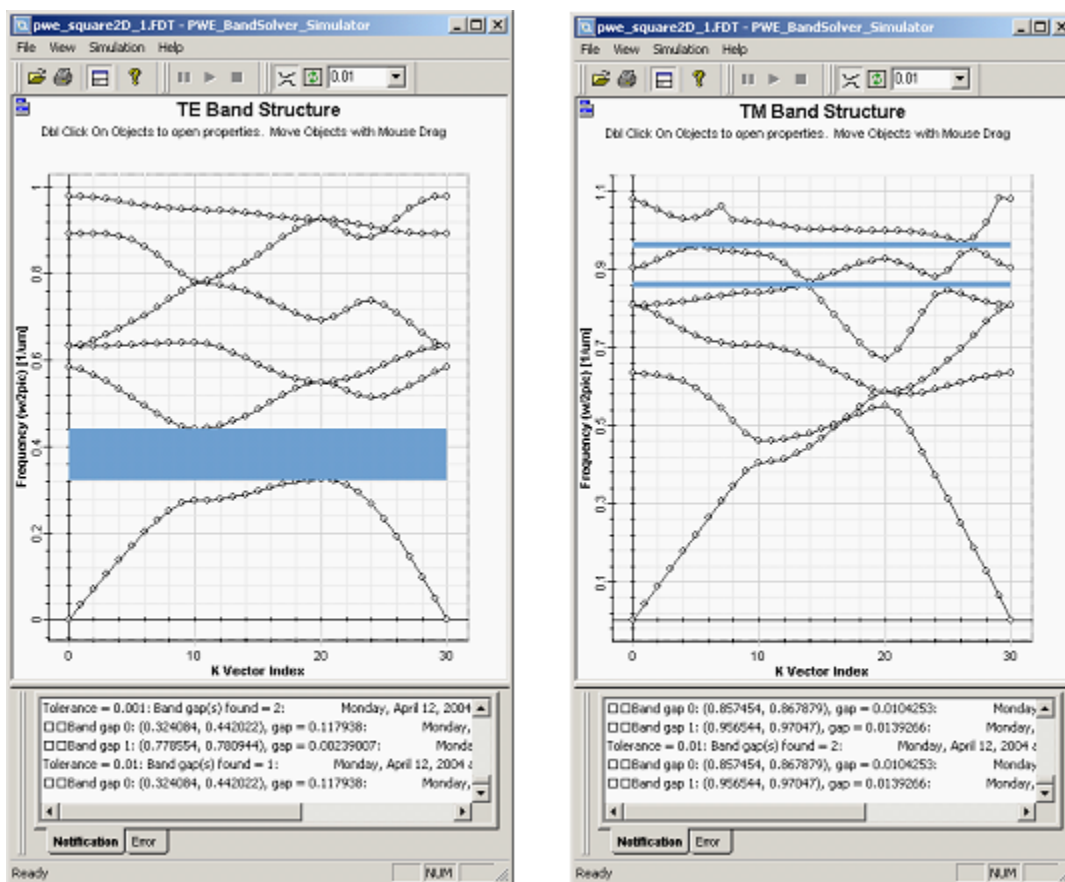


3. Simulation Results

When finished with editing band solver parameters click **Run...** to start the simulations. A simulation windows will be launched and simulation starts. You will be notified in the in the Notification tab window at the bottom about progress of the simulations. The engine first reports on the permittivity averaging process, then on the progress of calculations for individual k-vectors and finally informs you when the simulation is finished. At the end of the simulation the graph is populated with set of eigenfrequencies of individual k-vectors. You can use the 'Connect' button on the Diagram toolbar to connect the eigenfrequencies of individual bands as in the 1D case. You can also identify band gaps if there are any. To get band structure for TM modes you have to run the simulation again with TM polarization setting.

It is always possible to run with hybrid polarization setting. In this case both TE and TM modes are displayed but the band solver cannot distinguish the modes.

Figure 2 Band Diagram from PWE Band Solver



You can compare the calculated band diagrams with the results in reference [1].

Inversion Symmetry and Domain Origin

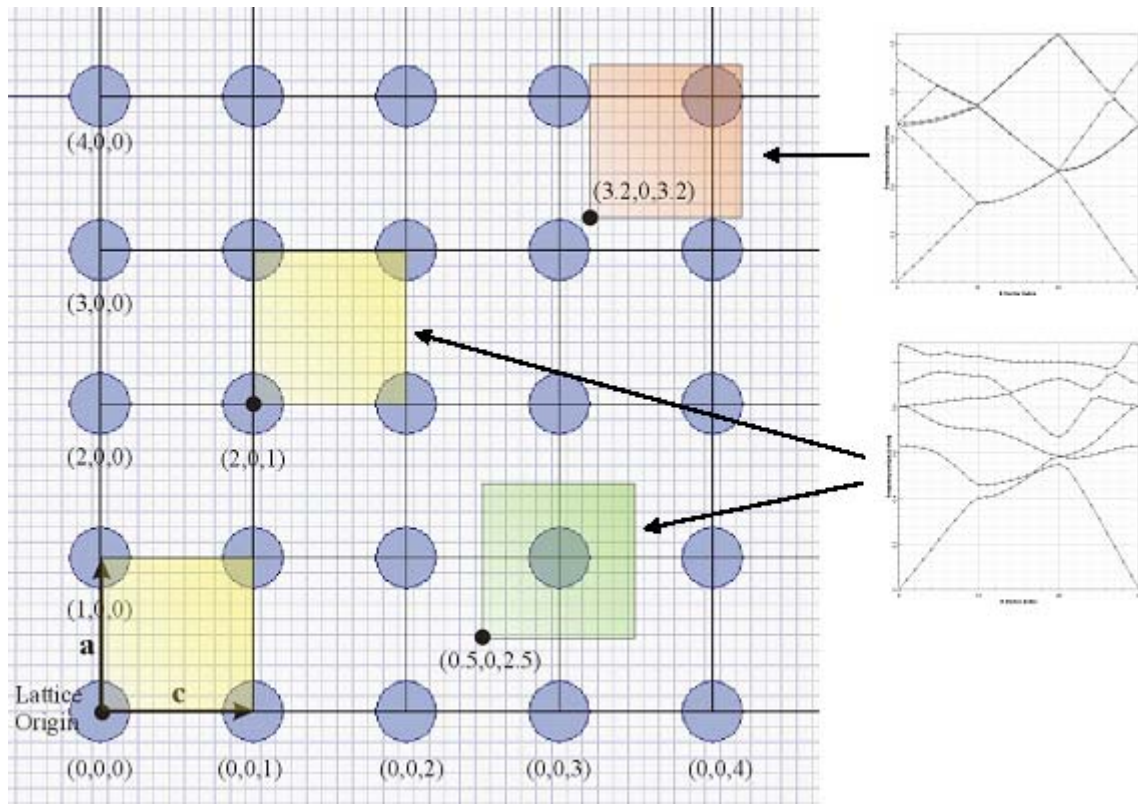
In case the simulated unit cell or supercell structure has inversion symmetry the operator matrix in the eigenvalue problem becomes a real symmetric matrix. This can be used to achieve significant savings in storage and as well as speed improvement. The inversion symmetry in the design is not detected automatically but user can notify the solver about its presence by checking the **Inversion Symmetry** check box. To obtain correct results, however, the unit cell (or supercell) has to have the inversion symmetry around the Domain Origin. The **Domain Origin** is specified in terms of the original lattice vectors (\bar{A} , \bar{B} , \bar{C}) and the lattice origin : $O_{lattice}$

$$DomainOrigin = O_{lattice} + A\bar{A} + B\bar{B} + C\bar{C}$$

It has great importance when one wants to use inversion symmetry option as well when a defect supercell is simulated. Figure 3 below shows the simulation domain of a unit cell for Domain Origin (2,0,1) and (0.5,0,2.5). Notice that the refractive index for the simulation is obtained from different parts of the layout. For the current sample we can leave the domain origin as (0,0,0) knowing that the unit cell has inversion symmetry. Check the **Inversion Symmetry** check box and run the simulation again (either TE, TM or both). Notice the simulation time improvement. You can deduce the simulation time from the Notification tab messages. What is going to happen if the simulation domain does not have an inversion symmetry? In such case the results will be incorrect. The solver simply samples the refractive index only on half of the domain assuming the second half is defined by the inversion symmetry. Set the Domain Origin to (3.2,0,3.2). Clearly Domain selected does not have an inversion symmetry (see figure below) and the results are incorrect. On the other hand the Domain Origin can be selected as (0.5,0,2.5) and possess the inversion symmetry again (green unit cell).



Figure 3 Inversion Symmetry and Domain Origin



It should be now clear that for simulations of unit cell it would be sufficient to have lattice structure of dimensions 1x1. The Domain Origin becomes also important in defining the supercells containing defects as for example a PC fiber or linear defects (waveguides).

2D hexagonal lattice

We are now going to verify band structure of 2D hexagonal lattice as reported in reference [1]. At this point you might want to save the current file under different name. The photonic structure we want to analyze consists of a hexagonal pattern of air holes in dielectric with permittivity 13. We have defined all the necessary materials and profiles at the beginning of this tutorial so the transition is easy.

To change the layout double click on the lattice to open **Crystal Lattice Properties** dialog. Change the lattice type from **2D Rectangular** to **2D Hexagonal**. Then **Edit** the properties of the elliptic waveguides (lattice atom waveguide). Change the minor and major radius from 0.2a to 0.48a and the profile to Chan_eps1. The last thing is to change the substrate from air to dielectric material eps13 (Edit >> Wafer Properties... >> 2D Wafer Properties) and check the index distribution in the 2D Refractive Index View.

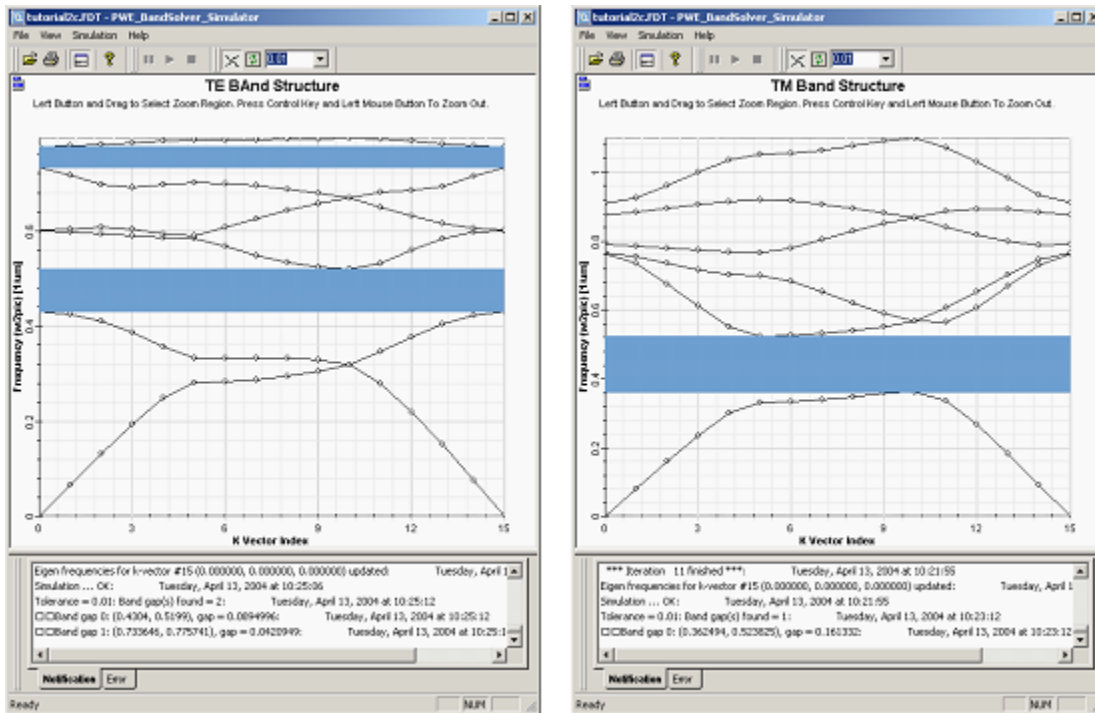


Before running simulation we want to change the Simulation parameters of the PWE band solver, to get desired polarization, number of bands, and mainly to set up correct k-path.

In the PWE Parameters dialog uncheck the Inversion Symmetry, select TE polarization, use defaults for lattice vectors and mesh (16x16). Make sure the Domain Origin is set to (0,0,0). Set Number of Bands to 6 and tolerance to 10-5. In the K-vector Path select the predefined HexagonalZX option. The definition of the Brillouin zone can be found in the Technical Background.

Run the simulation to obtain the results for TE and TM. Keep the results for further comparison. Now increase the mesh resolution to 32x32. Also notice that the structure has an inversion symmetry so you might check the Inversion symmetry check box. Run the simulation with new parameters and compare the results with the first simulations. Even though the structures might look similar you will notice a difference in band gaps. This is due to the rough discretization, which cannot make details of the layouts. The air occupies most of the unit cell with filling factor of 0.836.

Figure 4 Band Diagram for Hexagonal Lattice



Rotated 2D lattice

Occasionally you might use a lattice to build a more complicated 2D layout design. In such design the lattice might also be rotated. You do not have to create a new layout to analyze the lattice. Use the Default Lattice Vectors and Domain Origin to set the computational domain and to capture the correct periodicity. As an example rotate the 2D hexagonal lattice above by 10 degrees. Double click the lattice and in Lattice properties dialog box set the Azimuth angle to 10 degrees. Close the dialog box and open PWE Simulation Parameters dialog. Make sure you have selected defaults for the lattice vectors and Run. The band diagrams should be the same.

References:

[1] Joannopoulos, J.D., Meade, R.D., Winn, J.N., "Photonic Crystals, Molding the flow of light", Princeton University Press 1995

Lesson 13 - Analyzing 3D Photonic Crystals

Introduction

Most of the features of PWE band solver were demonstrated in Lessons 11 and 12. In this tutorial we apply the solver to a 3D problem of a fcc (face centered cubic) and diamond lattices of spherical air balls suspended in a dielectric medium. Such structures have been intensively studied in the past [2]. The fcc structure is known to lack a full photonic bandgap, whereas the diamond lattice, as first reported by Ho, Chan and Soukoulis in 1990, have a complete photonic band gap.

1. FCC Lattice of Air Spheres Suspended in Dielectric

- Create the Structure in Layout Designer
- Set Parameters of PWE Band Solver
- Run Simulation and Analyze Results

2. Diamond Lattice of Air Spheres Suspended in Dielectric

- Design the Lattice Structure
- Set Parameters and Run Simulation

1. FCC lattices of Air Spheres in Dielectric

1.1 Create a 3D rectangular lattice of dielectric spheres

Note:

- In this lesson, it is assumed that you already read the PWE tutorial [Lesson 11 - Analyzing 1D Photonic Crystals \(Bragg gratings\)](#) and [Lesson 12 - Analyzing 2D Photonic Crystals](#).
- For the details on how a lattice can be created, please refer to [Lesson 3—Photonic crystal and photonic band gap simulation](#) and [Lesson 9—FDTD Band Solver](#).
- For the details on how material and waveguide profile can be created, please refer to tutorial Lessons 1 through to Lesson 9.



- To define the variable, please input the variable name in the **Initial Properties** dialog box. Click OK to access the **Variables and Function** dialog box to define the values.

When a project is initialized, in the profile designer, please define two constant materials with name as "Air" and "eps13", and the refractive index as 1.0 and 3.6055 respectively. . As the air is already predefined as a default material we only need to create one new material with refractive index of ~3.6055.

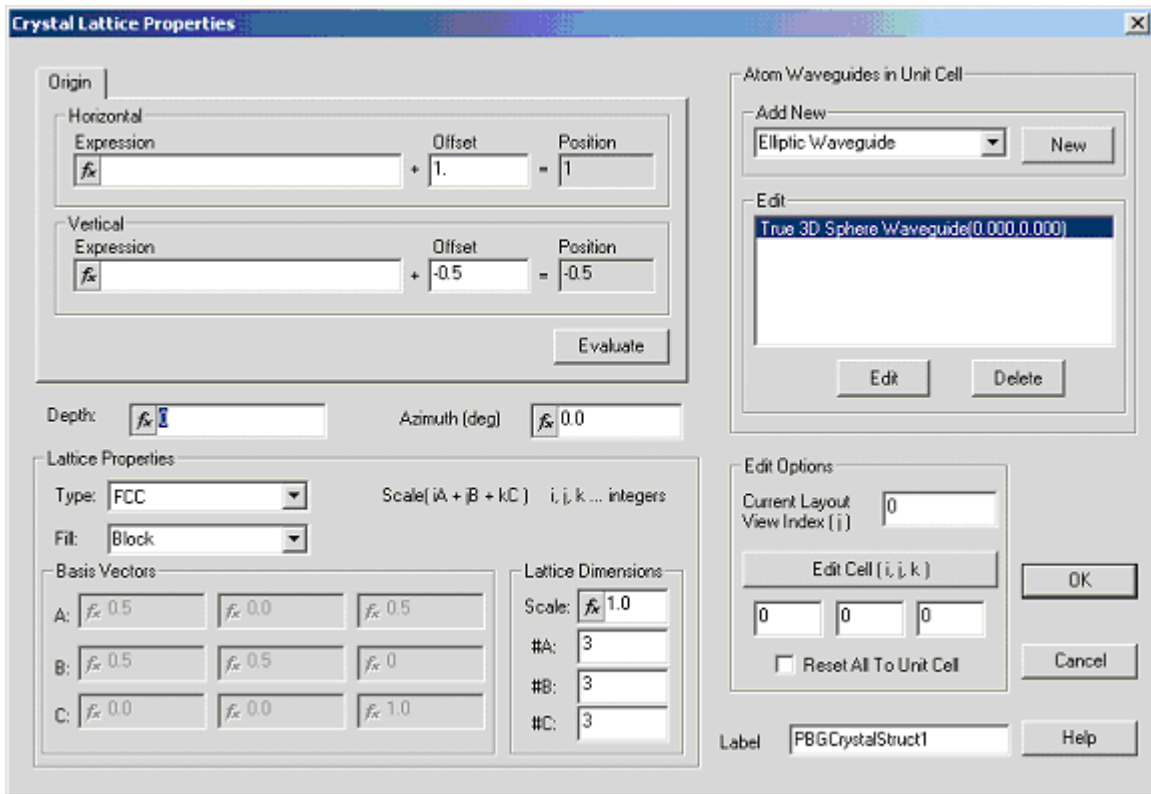
Please also define a channel default profile use Air or eps13. OptiFDTD layout designer requires this default even though you will not need it to build the photonic crystal.

In the project initial properties dialog box, Please define wafer dimensions as 5x5 microns, cladding material as eps13 and thickness 3 micron, substrate material eps13 and thickness 1micron.

In the layout designer click on the PBG Crystal Structure icon and place a lattice structure on a layout. Open Crystal Lattice Properties dialog box and specify Lattice Type as FCC. The lattice vectors will be automatically generated. Make sure the scale is set to 1.0 and number of lattice vector translations is set as (#A,#B,#C)=(3,3,3). (See Figure 1)



Figure 1 Crystal lattice Properties dialog box.



Enter new 3Dsphere object in the Atom Waveguides in Unit Cell. Edit the properties of the Sphere objects by setting the radius of 0.3716 and its material to Air. Return to the layout designer. Check the refractive index in the refractive index viewer and persuade yourself you created FCC lattice of air spheres submerge in dielectric.

1.2 Set simulation parameters

Open the PWE Simulation Parameters dialog box and set 3D solver. Hybrid polarization option will be automatically selected. The current version does not allow applying any symmetry constraints in 3D simulations. As our lattice vectors in case of FCC lattice are not standard FCC lattice vector, we want to set the lattice vectors for PWE simulation manually so that they correspond to the standard way. Uncheck the Use Defaults and set vectors as

$$\mathbf{a}=(0.5, 0.0, 0.5)$$

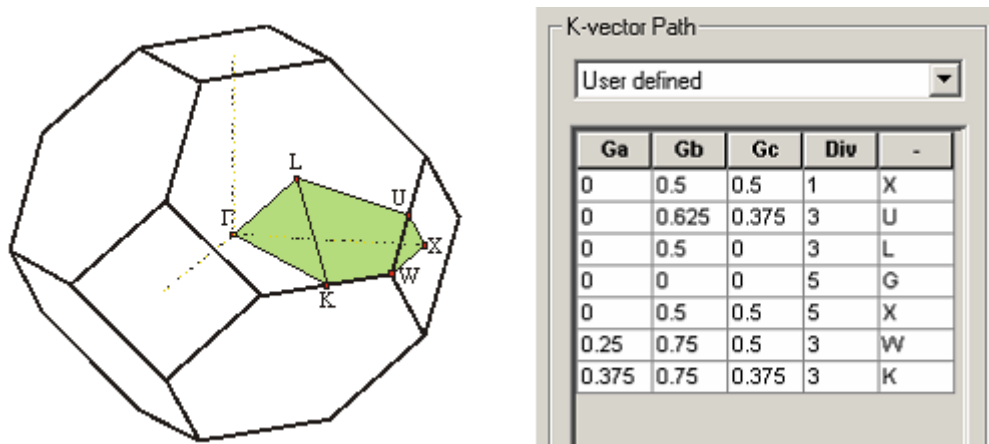
$$\mathbf{b}=(0.5, 0.5, 0.0)$$

$$\mathbf{c}=(0.0, 0.5, 0.5)$$

In this simulation use the mesh resolution as 16x16x16. To increase accuracy you might want to increase the mesh size later. The simulation time will significantly increase.

Next step is to define the k-path in terms of the reciprocal vectors. In this case we want to scan the irreducible first Brillouin zone. The definition of the points of higher symmetry will define the zone can be found elsewhere. The symmetry point, we will define are shown in [Figure 2](#).

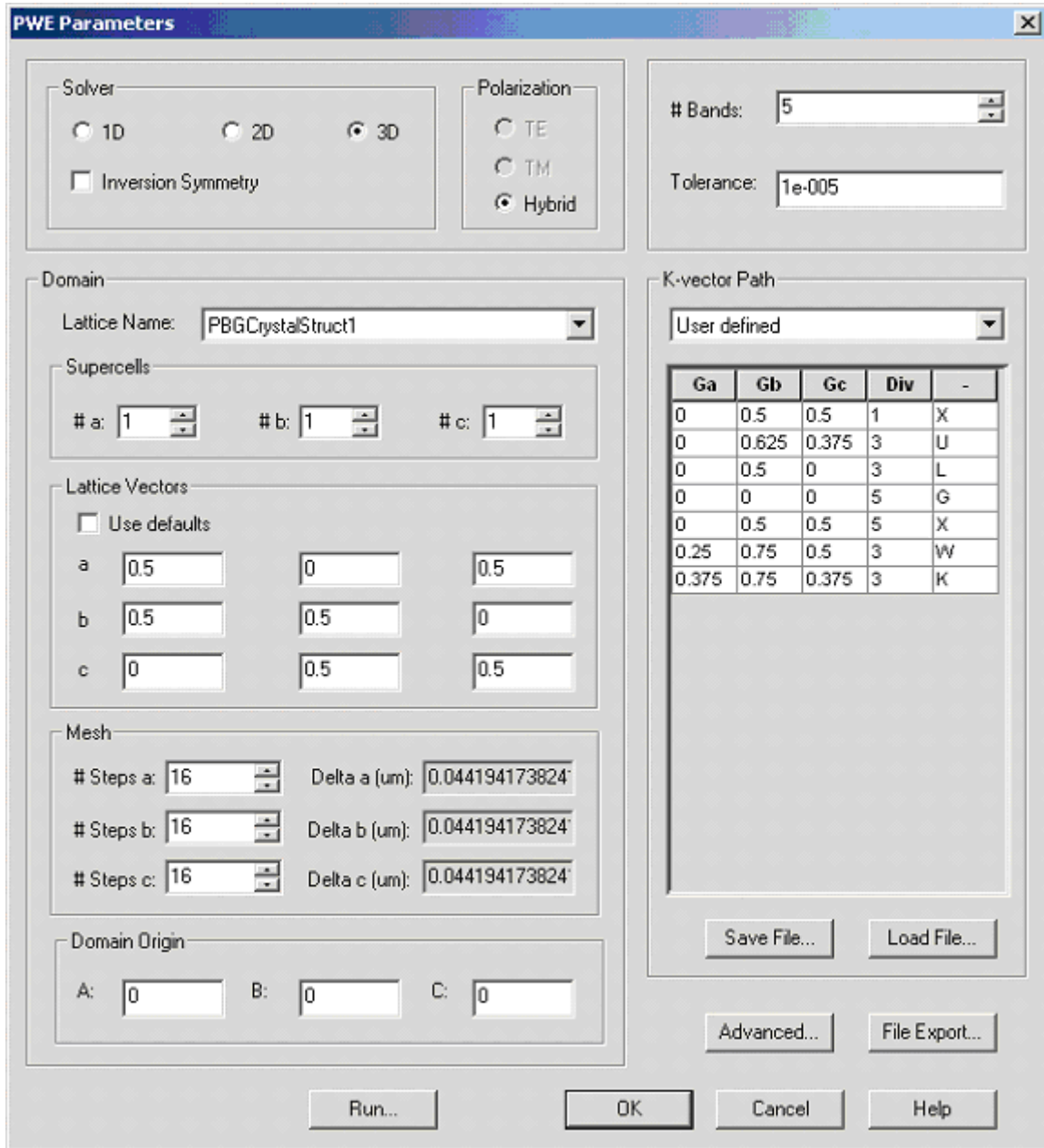
Figure 2 Schematic of the first Brillouin zone of FCC lattice (truncated octahedron) with high symmetry points (left) and defined k-path across the irreducible Brillouin zone (right).



To edit the k- path, Please chose the “**User defined**” in the **K-Vector Path** list, then right click on the k-path area, and select “Add” to edit the terminal point or stop point for a k-vector path.

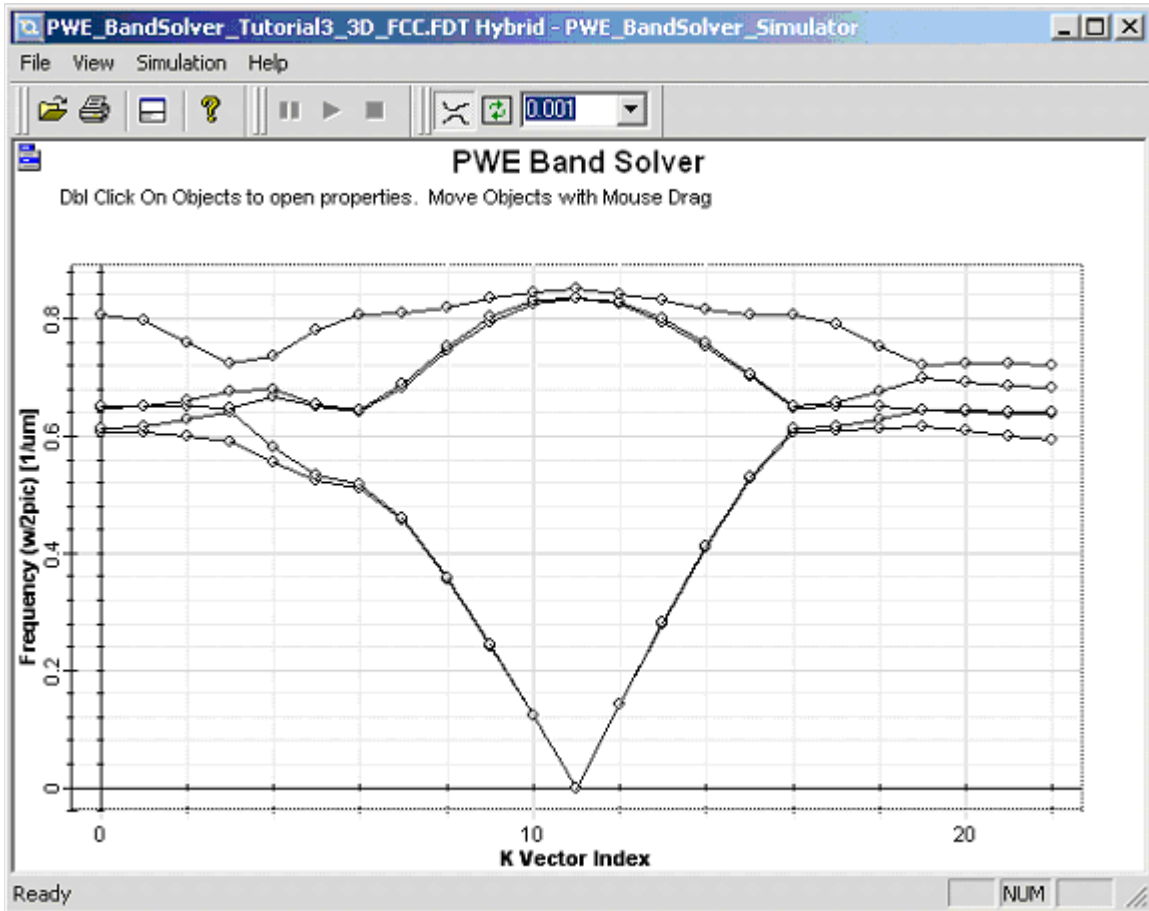
[Figure 3](#) shows the PWE simulation parameter dialog box.

Figure 3 PWE simulation parameters dialog box



Add an input wave plane in the layout, and then you can perform the PWE band solver simulation. The resulting band structure does not contain any complete band gap. Similar results can be found for example in reference [1][2]. (See Figure 4).

Figure 4 Hybrid band structure of FCC lattice (mesh16*16*16)



2. Diamond Lattice of Air Spheres in Dielectric

2.2 Layout design of the diamond lattice

The fcc lattice of air balls in dielectric was not found to possess band gaps. However, it has been shown that in case of diamond lattice band gap structure can be detected. The diamond lattice is composed of two interpenetrating fcc lattices, one displaced $\frac{1}{4}$ of a lattice constant in each direction from the other. We can easily create such structure in the layout designer by simply adding another fcc lattice.

Save the file under different name to keep the original fcc lattice design. Double click on the fcc layout, the **Crystal Lattice Properties** dialog box presents. In the "Atom



Waveguides in Unit Cell” region, select **“True 3D Sphere Waveguide ”** and click new will start to add another atom in the existing fcc layout. Please shift this new atom position by $\frac{1}{4}$ in all the (x, y, z) direction. Set the two Sphere atom’s radius as 0.325. Check the refractive index and persuade yourself this is indeed a diamond lattice. As reported in [1] the band gap should be maximized for sphere radius of 0.325.

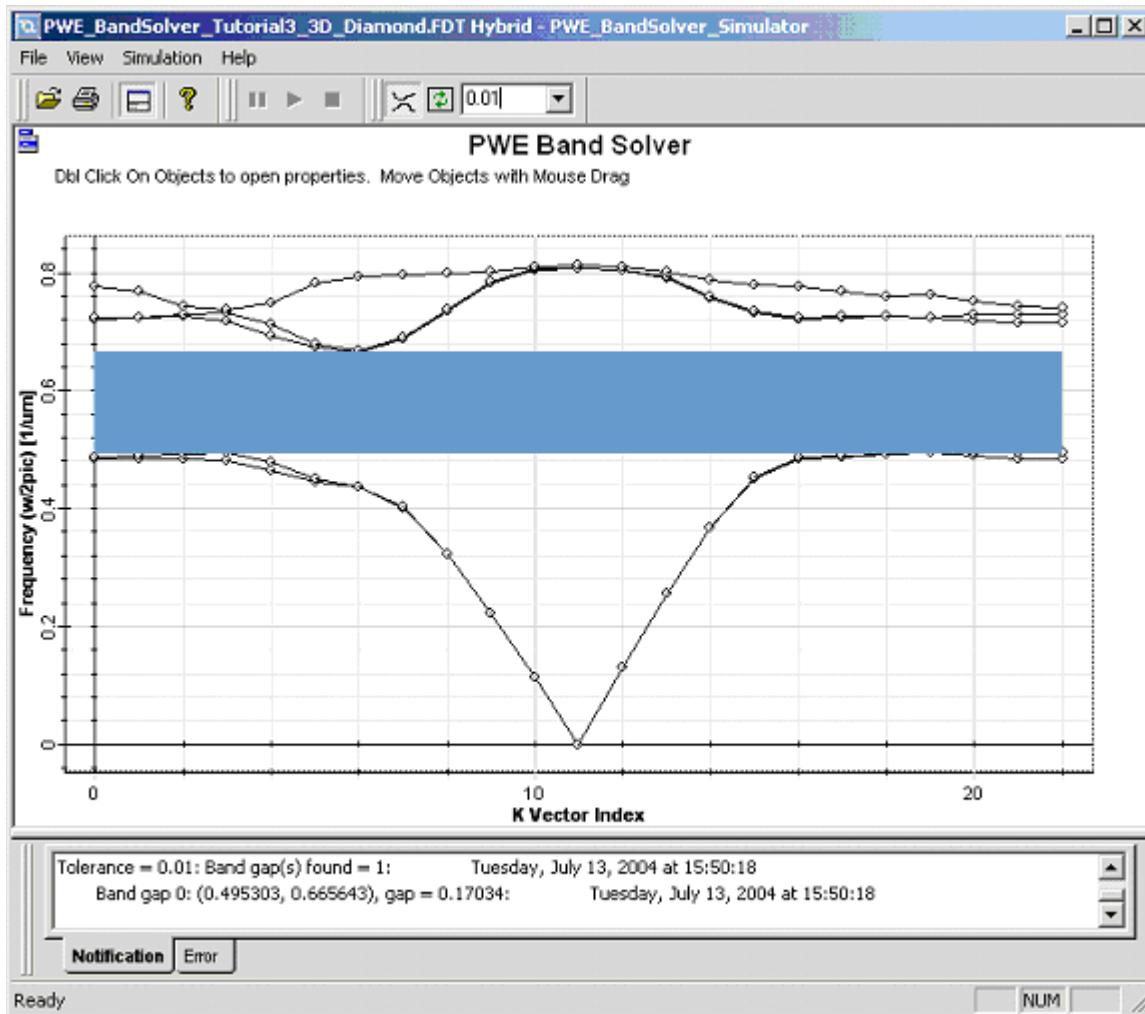
2.2 Set parameters and run simulation

Keep the PWE band solver simulation parameter setting from the previous example, and run the simulation

The obtained band structure of the diamond lattice clearly has a complete band gap. Click on the **Locate Band Gap** button on Diagram toolbar to find details on the band gap: (0.4954, 0.6656), gap=0.170.



Figure 5 Hybrid band structure of diamond lattice (mesh16*16*16)



References:

- [1] Joannopoulos, J.D., Meade, R.D., Winn, J.N., "Photonic Crystals, Molding the flow of light", Princeton University Press 1995
- [2] Ho, K.M., Chan, C.T., Soukalis, C.M., "Existence of photonic gaps in periodic dielectric structures," Phys.Rev.Lett. **65**, p3152.



Lesson 14 - Analyzing 2D Defects in Photonic Crystals

Introduction

In the previous tutorials we were interested in finding band gaps of 1D, 2D and 3D photonic crystal structures. No modes are allowed with frequencies inside the gap. By perturbing a lattice at a single site we may permit an existence of a localized point-defect mode or set of such modes that have frequencies within the gap. We will show how to detect and view such defects in 2D photonic crystals in this tutorial.

Note:

- In this lesson, it is presumed that you already read the PWE Tutorials 1 to 3.
- For the details on how a lattice can be created, please refer to [Lesson 3—Photonic crystal and photonic band gap simulation](#) and [Lesson 9—FDTD Band Solver](#).
- For the details on how material and waveguide profile can be created, please refer to Lesson 1 through to Lesson 9.
- To define the variable, please input the variable name in the **Initial Properties** dialog box. Click **OK** to access the **Variables and Function** dialog box to define the values.

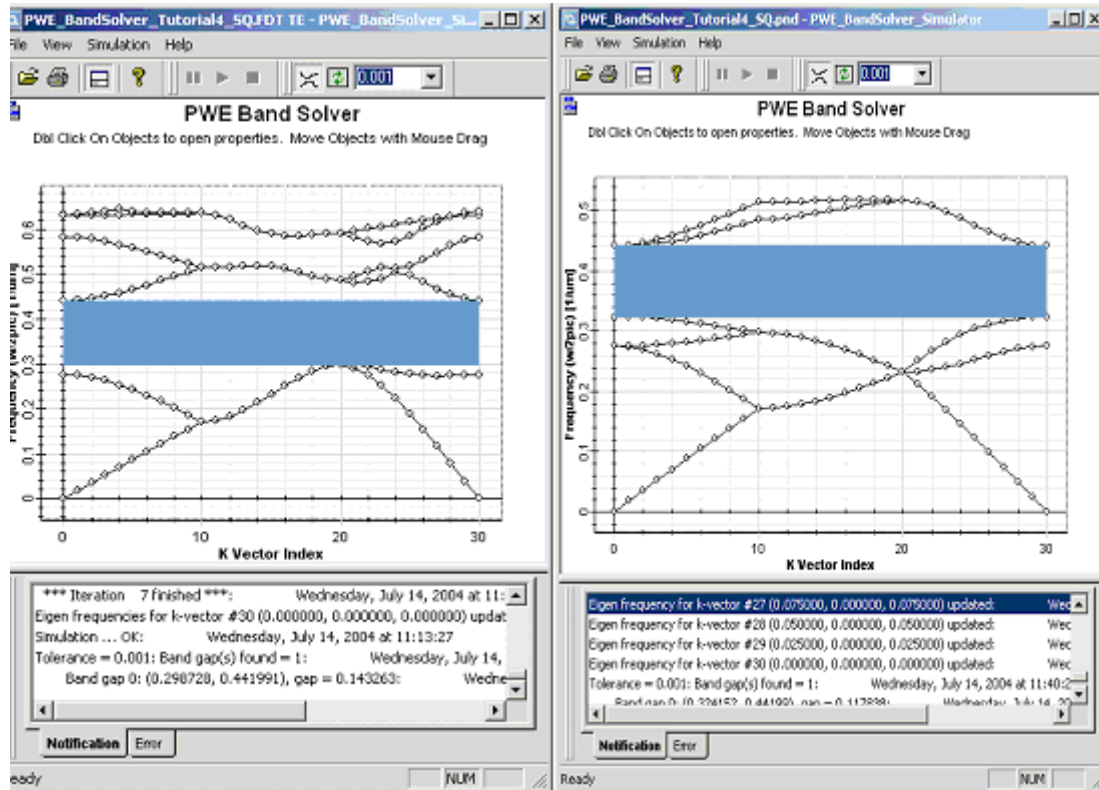
1. Square 2D lattice

1.1 Setting and Simulating Supercell

The rectangular lattice of dielectric rods with permittivity 8.9 suspended in air was investigated earlier in [Lesson 2—Input wave setup](#). We found that the TE solutions (Optiwave convention) exhibit a band gap in the range between 0.324 and 0.442. First we have a look what is going to happen if we increase the simulation domain so that it contains several unit cells. Change the supercell definition to $(\#a,\#b,\#c)=(1,1,2)$ and mesh to $16 \times 16 \times 32$. Run a TE simulation again. Notice that the band diagram looks very much different than in the case of $1 \times 1 \times 1$ supercell (See [Figure 1a](#)). A band gap can be still located but this time it is wider and spans from 0.291 to 0.442. Change the supercell again to $(2,1,2)$ and mesh to $32 \times 16 \times 32$ and run simulation again. This time the band structure is again totally different (See [Figure 1b](#)). Nevertheless, the band

gap in the last simulation is correct. The important fact to notice is so called folding of the bands. For (1,2) supercell there are two bands below the band gap, and in case of (2,2) supercell there are four bands. This is due to the fact that the new domain contains 2 and 4 elementary unit cell within the supercell.

Figure 1 Band diagram of a supercell 1x2 (left) and supercell 2x2 (right) for k-path selected along the irreducible Brillouin's zone for square lattice ('SquareZX': G-X-M-G).



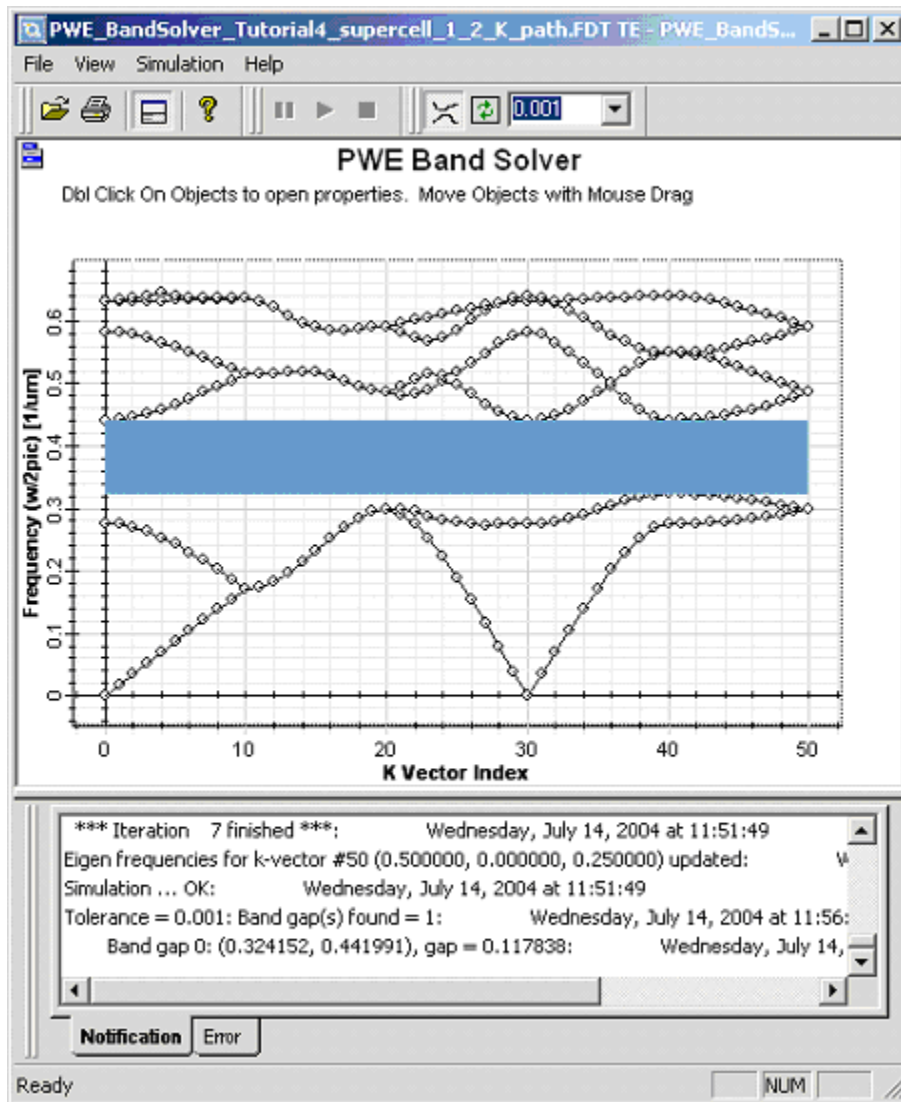
By creating a (1,2) supercell we broke up the 4-fold symmetry of the original square cell and what used to be an irreducible Brillouin zone in case of square lattice is only a part of a new irreducible zone in case of rectangular supercell. To get a correct band gap we need to scan along the edges of the irreducible Brillouin zone. Add two new major k-points to the k-path:

$$X_2 = (0.5, 0.0, 0.0) \text{ 10 divisions}$$

$$M = (0.5, 0.0, 0.5) \text{ 10 divisions}$$

Run the simulation for (1,2) supercell. You will again observe the band folding and this time you will get correct band gap in agreement with our original simulation.

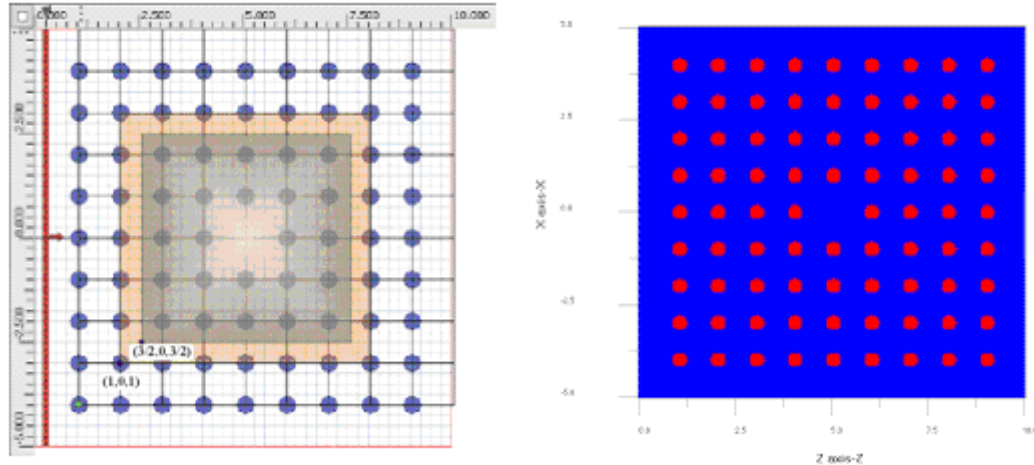
Figure 2 Band diagram of the supercell 1x2 for k-path along the edges of irreducible Brillouin's zone for rectangular lattice (G-X-M-G-X2-M)



1.2 Setting up a defect

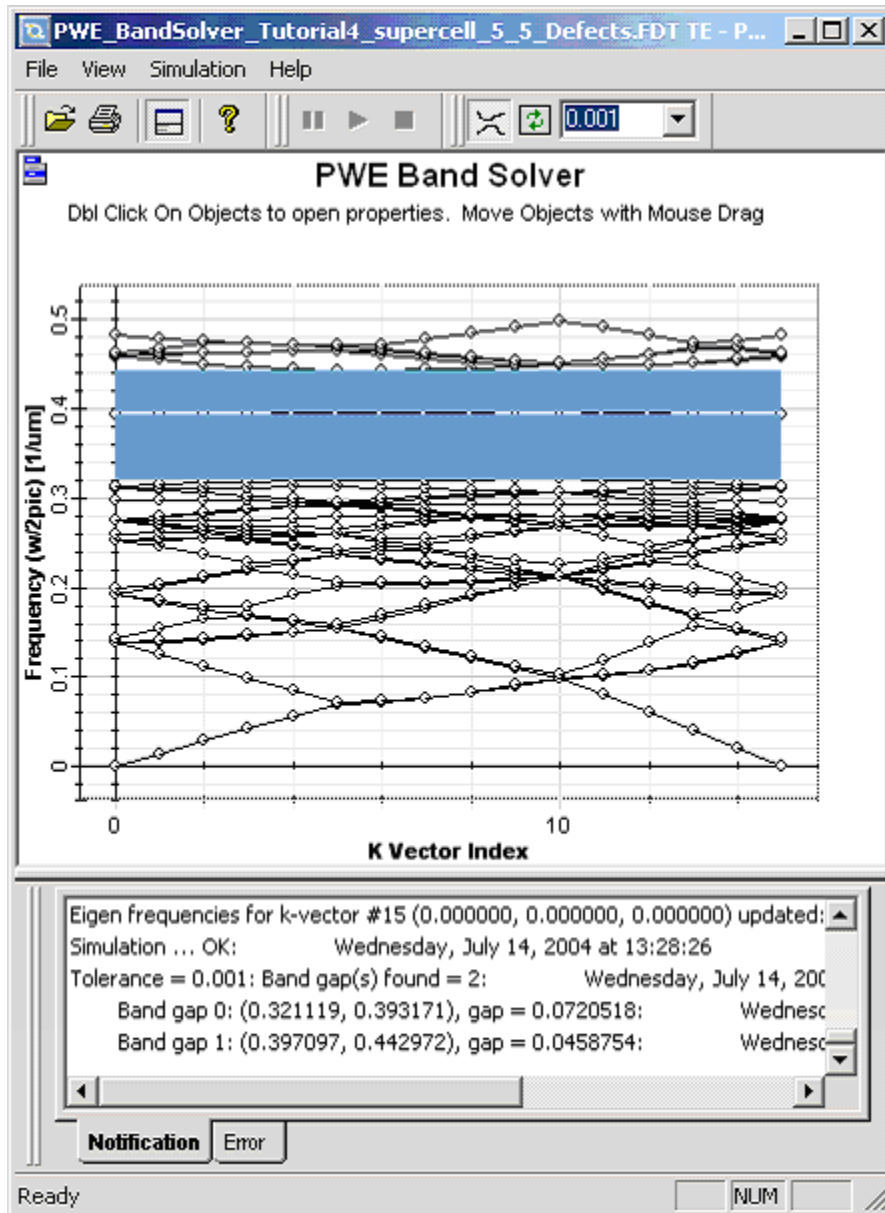
Changing the size or refractive index of a selected atom on the lattice can create a defect in the lattice. We will investigate a defect created by a missing dielectric rod. First please set the cell number to 9X9 on the original layout, then we need to remove the element from the lattice. Select the lattice in the layout, the 'PBG Crystal Structure Cell Editing Tool' becomes highlighted in the Tools toolbar. Select it, then right click on the unit cell (5,5) and select Cells Off. The cylinder in the center of the lattice will be turned off. You can check this in 2D refractive index view (see Figure 3).

Figure 3 Layout (left) and refractive index (right) of a square lattice with missing dielectric rod (defect). Supercells 5x5 and 6x6 are shown with domain origins.



What is going to happen if we run a simulation on a supercell domain with the defect? If there is a localized defect mode confined close to the defect we should see a straight band within the band gap of the unperturbed square lattice, i.e. in the interval (0.324, 0.442). If the simulation domain is small and the localized mode extends to the simulation boundaries there is coupling between the adjacent defect on the supercell lattice and its result will be a defect band within the original band gap. Thus when simulation defects we need to insure that the simulation domain is large enough so that the localized band if it exist is narrow within our tolerance. The following simulation of the whole k-path is often not necessary to study point defects. A single k-vector simulation will usually suffice. It is however illustrative. We will perform simulation on a supercell 5x5 so that we can observe the localized state. We have already created the defect on the layout. Now we have to set the simulation Domain Origin. In the figure above you can see two rectangular regions marked by different colors. The inner region defines a suitable 5x5 supercell, the outer rectangle 6x6 supercell. Notice that a supercell selected in such manner possesses an inversion symmetry, which we can use to speed up simulations. The picture also shows the domain origin coordinates. For the 5x5 supercell set the Domain Origin to (1.5, 0.0, 1.5). We need to have a reasonable resolution. Selecting 64x64 mesh will be enough for demonstration. For the supercell of dimensions 5x5 we expect the first band will be folded 25 times and thus we will need more than 26 bands to see the defect if it exist. Select 30 bands. Make sure TE polarization is selected. As we have a square supercell a default SquareZX k-path is selected. Also check the inversion symmetry to speed up calculations. The simulated results are shown in [Figure 4](#).

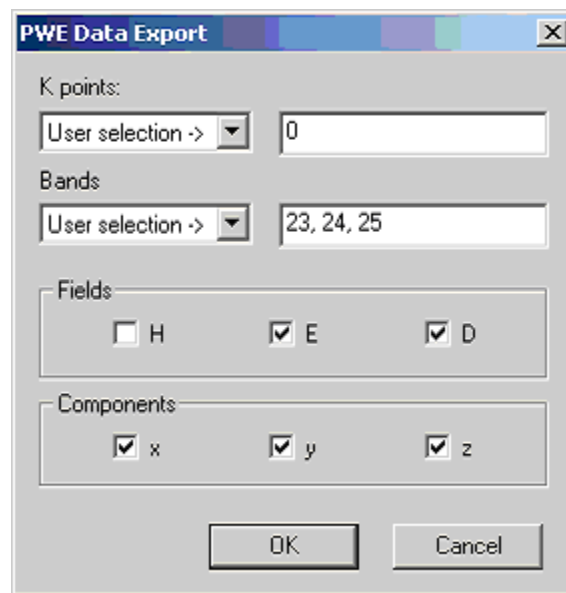
Figure 4 Band diagram of the rectangular supercell. The defect bands are flat bands within the band gap.



To detect a point defect it is usually enough to run a simulation and ideal lattice, find band gaps and then run simulation for a defect and a single k-vector. The solutions within a band gap will be the modes of interest and by a visual check of the field profiles we can estimate whether the selected supercell domain is large enough.

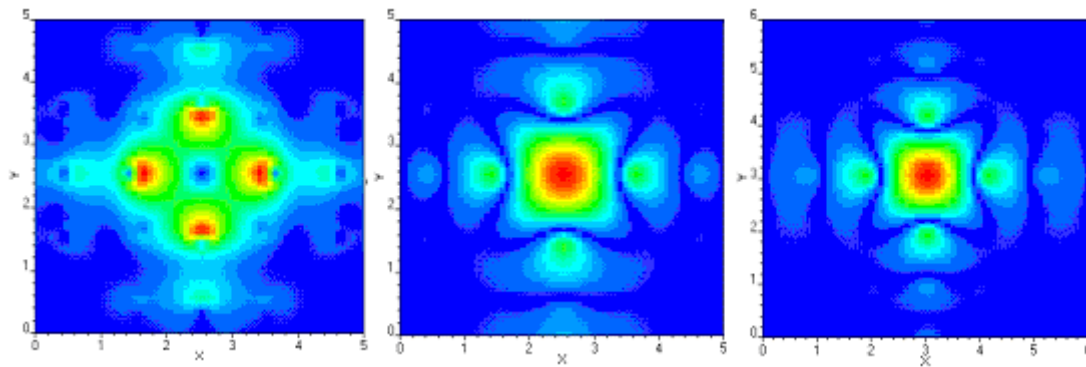
Next step, we what show how can we get the modal field distribution, in the PWE Band Solver Parameters dialog box, k-path section leave only the gamma point and delete all the other major points. Leave the mesh set to 64x64, TE polarization and set the supercell to 5x5 with Domain origin at (3/2,0,3/2). Set number of bands to 30 to account for the first band folding. Click on the **File Export** button to open the **PWE Data Export** dialog box (See [Figure 5](#)). Select User selection for K points and in the right input field enter the index for the exported k-vector. In this case we run simulation for single k-vector and as the indexing of the k-vector starts from zero enter 0. In **Bands** section select User Selection. The first band is going to be folded 5x5=25times, so that index 24 corresponds to the defect. Choose 23, 24, and 25 to export both the defect profiles as well as the profiles of modes below and above the defect. Select all the fields and components for export. Close the dialog box and run simulation.

Figure 5 PWE Data Export dialog box. User specifies k-vectors, bands as well as individual components to be exported.



The exported field pattern is in the sub folder where the current project is saved, you can use our OptiWave 3D viewer to observe these field patterns, and [Figure 6](#) shows simulated results under different condition.

Figure 6 Localized defect mode of a rectangular lattice of dielectric cylinders ($r=0.2$, $\epsilon=8.9$) in air. From left to right there are electric field amplitude, magnetic field amplitude of 5×5 supercell and magnetic field amplitude for a supercell 6×6 .



References:

- [3] Joannopoulos, J.D., Meade, R.D., Winn, J.N., "Photonic Crystals, Molding the flow of light", Princeton University Press 1995
- [4] Ho, K.M., Chan, C.T., Soukalis, C.M., "Existence of photonic gaps in periodic dielectric structures," Phys.Rev.Lett. **65**, p3152

NOTES:



Lesson 15 - Grating Simulation

Part 1 --- Simulations of Gratings Created with VB Script

Grating layouts in most cases are the periodic structure. There are two ways in OptiFDTD to realized the periodic layout: PBG editor and VB scripting, PBG layout and corresponding simulations are discussed in Lesson 3, Lesson 11 - 14. This lesson will focus the following features:

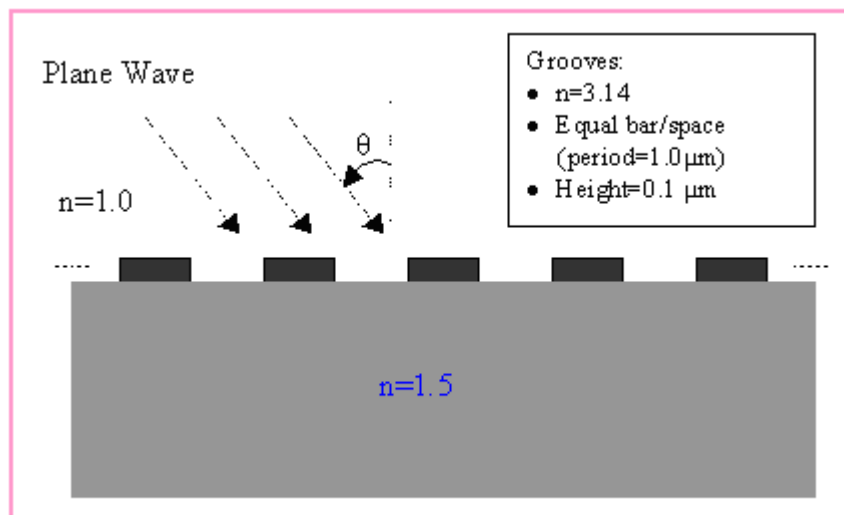
- Using VB scripting to generate the grating (or periodic) layout.
- Grating layout simulation and post-processing analysis

Note: It is assumed that you are familiar with [Lesson 1—Getting started](#) and with material and profile definition.

Introduce the layout

We are going to simulate a 2D grating layout that is shown in the Figure 1.

Figure 1 Layout



Note: Note: The corresponding project file can also be found in the **Sample** file folder, **Sample37_2D_VB_Script_Grating.FDT**



Define a 2D grating layout with VB scripting

- | Step | Action |
|-------------|--|
| 1 | <p>Start a new project from Waveguide Layout Designer by select “New” in the file menu.</p> <p style="padding-left: 40px;"><i>Initial Properties</i> dialog box appears</p> |
| 2 | <p>In the <i>Initial Properties</i> dialog box set the following parameters</p> <p style="padding-left: 40px;">Wafer Dimensions</p> <p style="padding-left: 80px;"><i>Length (mm): 8.5</i></p> <p style="padding-left: 80px;"><i>Width (mm): 3.0</i></p> <p style="padding-left: 40px;">2D wafer properties:</p> <p style="padding-left: 80px;">Wafer refractive index: Air</p> |
| 3 | <p>Click Profiles and Materials.</p> <p style="padding-left: 40px;"><i>The Profile Designer window appears.</i></p> |
| 4 | <p>Click Profiles and Materials.</p> <p style="padding-left: 40px;"><i>In the Profile designer, under the folder “OptiFDTD_Designer1”, define and store the following dielectric materials.</i></p> <p style="padding-left: 80px;">Name: N=1.5</p> <p style="padding-left: 80px;">Refractive index (Re:): 1.5</p> <p style="padding-left: 80px;">Name: n=3.14</p> <p style="padding-left: 80px;">Refractive index (Re:): 3.14</p> |
| 5 | <p>In the profile designer, under the folder OptiFDTD_Designer1, define the following channel profiles</p> <p style="padding-left: 40px;">Name: ChannelPro_n=3.14</p> <p style="padding-left: 40px;">2D profile definition, Material: n=3.14</p> <p style="padding-left: 40px;">Name: ChannelPro_n=1.5</p> <p style="padding-left: 40px;">2D profile definition, Material: n=1.5</p> |
| 6 | <p>In the <i>Initial Properties</i> dialog box, Set <i>ChannelPro_n=3.14</i> as the default profile, and click “OK” to start the main designer</p> <p style="padding-left: 40px;"><i>OptiFDTD_Designer windows appears</i></p> |
| 7 | <p>In the OPTiFDTD_Designer window, Draw the following Objects</p> <p style="padding-left: 20px;">a. Linear waveguide 1</p> <p style="padding-left: 40px;">Label: linear1</p> <p style="padding-left: 40px;">Start Horizontal offset: 0.0</p> |



Start vertical offset: -0.75

End Horizontal offset: 8.5

End vertical offset: -0.75

Channel Thickness Tapering: Use Default

Width: 1.5

Depth: 0.0

Profile: ChannelPro_n=1.5

b. Linear waveguide 2

Label: linear2

Start Horizontal offset: 0.5

Start vertical offset: 0.05

End Horizontal offset: 1.0

End vertical offset: 0.05

Channel Thickness Tapering: Use Default

Width: 0.1

Depth: 0.0

Profile: ChannelPro_n=3.14

8 In the In the OPTiFDTD_Designer window, define an horizontal input plane with following properties:

Continuous Wave

Wavelength: 0.63

General:

Input field Transverse: *Rectangular*

X Position: 0.5

Direction: Negative Direction

Label: InputPlane1

2D Transverse:

Center Position: 4.5

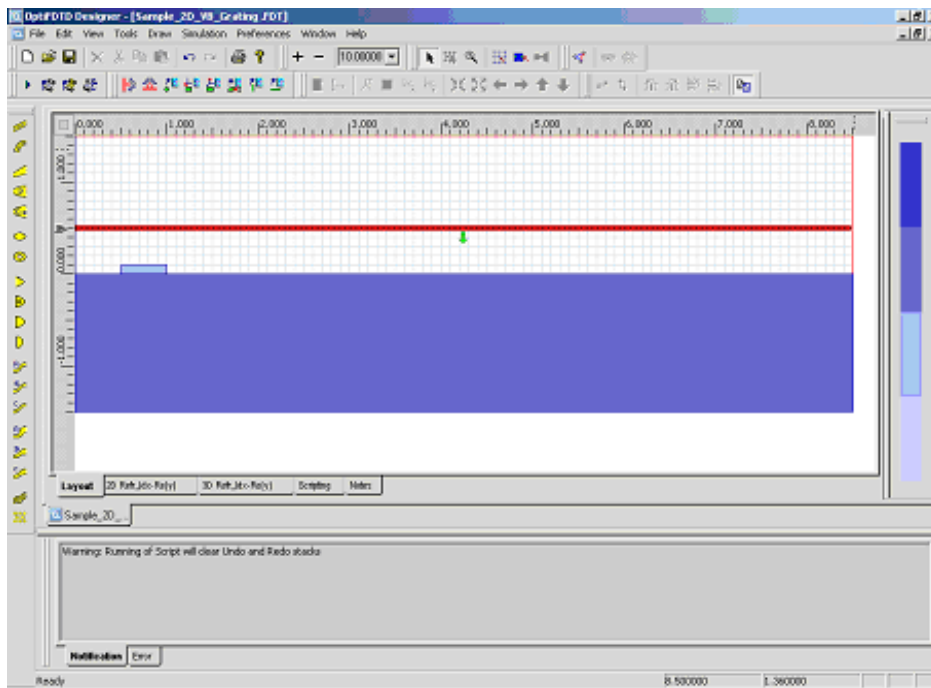
Half width: 5.0

Titlitng Angle: 45

Effective Refractive Index: Local

Amplitude: 1.0

Figure 2 OptiFDTD Designer window after Step 8.



- 9 Click "**Layout Script**" Shortcut tool bar or select "Generate Layout Script..." under the **Simulation** menu. This step will transform the layout object to the VB scripting code. The software will ask: "Generate Layout Script? This will overwrite the current script." Click **Yes**.

*The **Scripting** page appears*

- 10 Click "Layout" button to go to the Layout window, and delete all the objects in the layout window.

- 11 Click "**Test Script**" shortcut toolbar or select "**Test Script**" in the Simulation Menu. This will run the VB script code.

Now all the designed objects come back from VB scripting code. The layout should look like figure 2

(This steps shows that the layout can be designed by VB script)

- 12 Click " Scripting" button to go to the scripting page. Modify the Linear2 code paragraph as the following:

Dim Linear2

for m=1 to 8

Set Linear2 = WMgr.CreateObj ("WGLinear", "Linear2"+Cstr(m))

Linear2.SetPosition **0.5+(m-1)*1.0**, 0.05, **1+(m-1)*1.0**, 0.05

Linear2.SetAttr "WidthExpr", "0.1"

Linear2.SetAttr "Depth", "0"

Linear2.SetAttr "StartThickness", "0.000000"

Linear2.SetAttr "EndThickness", "0.000000"

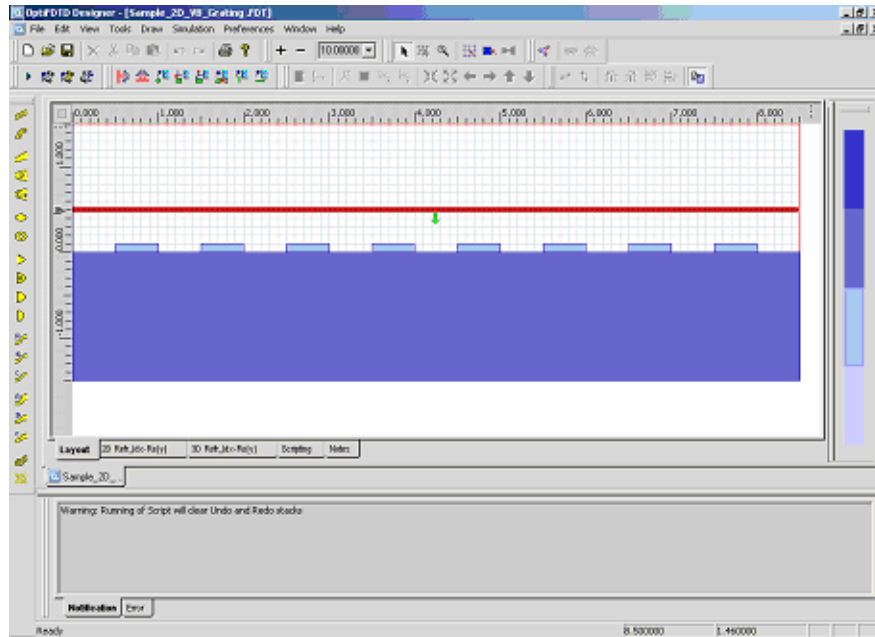
Linear2.SetProfileName "ChannelPro_n=3.14"

Linear2.SetDefaultThicknessTaperMode True



- 13 Click “**Test Script**” shortcut toolbar to run the Modified VB script code. The grating layout is generated, the layout is shown in [Figure 3](#).

Figure 3 Grating layout generated by VB scripting after Step 13.



Note: As has been demonstrated:

- a. VB scripting provides a way to generate the periodic layout.
- b. VB script can also design other objects that can be draw in the layout, such as input plane, Observation Objects.
- c. For more detail information about VB scripting, please refer to the VB Scripting Reference.

Make sure you save the layout.

Setup simulation parameters

- | Step | Action |
|------|---|
| 1 | Select “ 2D simulation parameters... ” under the Simulation menu
Simulation Parameters dialog box appears |
| 2 | In the Simulation Parameters dialog, set up the following parameters
TE simulation
Mesh Delta X: 0.015
Mesh Delta Z: 0.015
Time Step Size: Auto
Run for 1000 Time steps |
| 3 | Click Advanced Button to set up the Boundary condition
Set X and Z edge as Anisotropic PML boundary condition.
Number of Anisotropic PML layers: 15
Set other parameters with default value. |

Perform the simulation

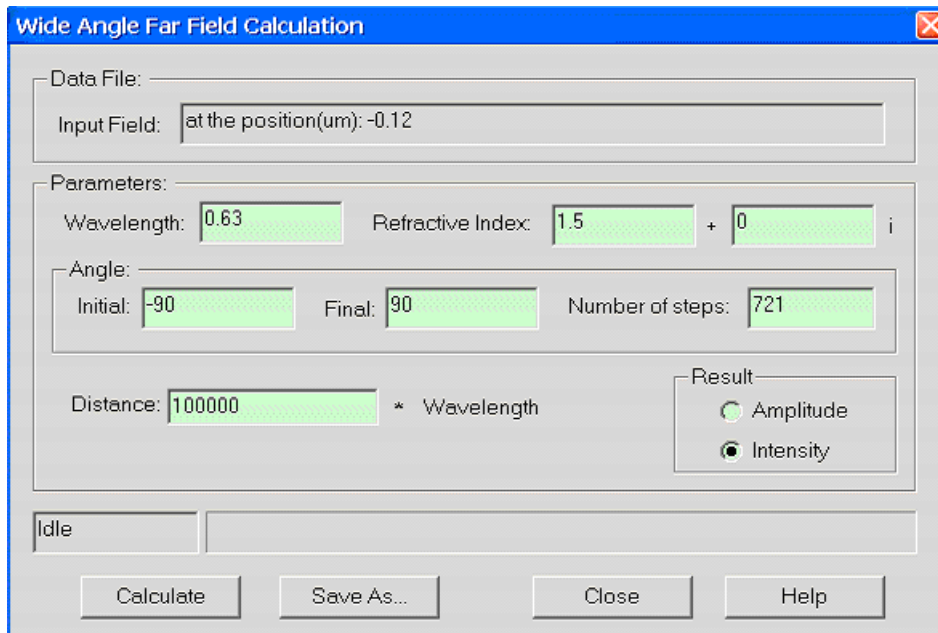
- Click **Run** button in the Simulation Parameters to start the Simulation
- In the Analyzer, the time domain response for each field components can be observed
- After the simulation, click “**Yes**” to start the Analyzer.

Perform far field analysis for the diffraction wave.

- | Step | Action |
|------|--|
| 1 | In the OptiFDTD Analyzer, select “ Crosscut Viewer ” in the Tools
Crosscut Viewer window appear |
| 2 | In the crosscut viewer, select “ Definition of the Cross Cut ” as <i>z-direction</i> . |
| 3 | Move the slice position to mesh point equal to 92, (Position: -0.12)
Observe the near field in the current slice |
| 4 | Select “ Far Field ” in the tools menu of cross cut viewer.
Far field transform dialog box appears. (Figure 4) |



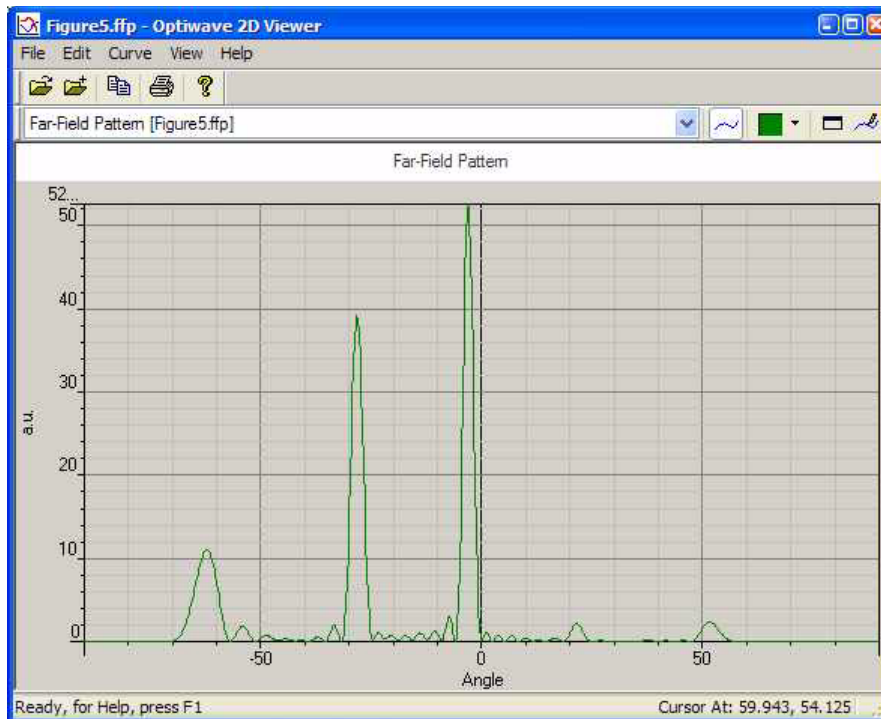
Figure 4 Far-field Calculation dialog box



- 5 In the Far Field Calculation dialog box. Set up the following parameters.
 - Wavelength:** 0.63
 - Refractive index:** 1.5+0i
 - Angle Initial:** -90.0
 - Angle Final:** 90.0
 - Number of Steps:** 721
 - Distance:** 100,000*wavelength
 - Intensity**
- 6 Click “**Calculate**” button to start the calculation and save the results as **Farfield.fpp**.
- 7 Start the “**Opti 2D Viewer**” and load the **Farfield.fpp**. The far field is shown in Figure 5.



Figure 5 Far field Pattern in “Opti 2D Viewer”



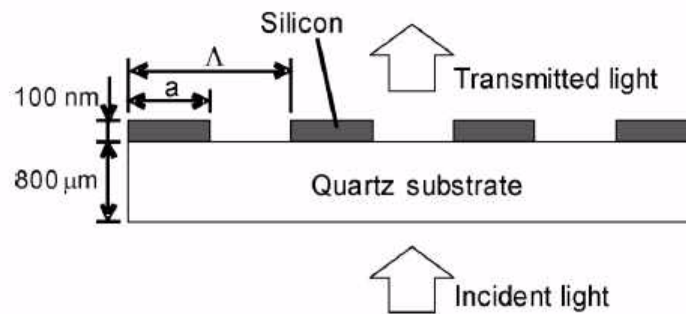
Part 2 --- Calculate the transmission and reflection spectrum from grating unit cell

Silicon subwavelength gratings on quartz substrates can function as a color filter. This has been shown the following published paper:

- [1] Yoshiaki Kanamori, Masaya Shimono, and Kazuhiro Hane, “Fabrication of Transmission Color Filters Using Silicon Subwavelength Gratings on Quartz Substrates”, IEEE PHOTONICS TECHNOLOGY LETTERS, VOL. 18, NO. 20, OCTOBER, 2006, pp. 2126-.

The layout sketch taken from the above reference is shown in [Figure 6](#). The published reference paper also shows the measurement results and the simulation results with RCWA method. For such a periodic grating with normal incident wave, OptiFDTD simulation can only pick up one unit cell with the transverse boundary set as the periodic boundary condition and input transverse beam pattern is set as rectangular wave (plane wave). The corresponding project file can be found in the Sample file folder, the file is named as: “X64_sample55_2D_Silicon_Subwavelength_Grating.fdt”

Figure 6 Figure 6 Silicon Subwavelength Gratings [1]



Please open this layout with OptiFDTD layout designer. Double clicking on each object in the layout to check the settings:

- The layout 2D wafer width (x-direction domain width) is set as 0.4μm, which is the red color filter grating's periodic length.
- The grooves material is silicon which uses the Lorentz_Drude model
- Time domain input wave is Gaussian Modulated Continuous Wave (GMCW); the center wavelength is set as 0.55μm. Right click on the input spectrum graph and select the zoom in tool to enlarge the spectrum region, the bandwidth can be found covers 0.4um to 0.8um.
- Transverse input beam pattern is set as rectangular wave with size larger than the x-direction domain size. This makes the input beam works as a truncate plane wave.
- The x-direction boundary condition is set as periodic boundary condition (PBC). This can be found by clicking the **advanced** button in the **Simulate 2D using 64bit** simulator dialog box.
- The spectrum wavelength range is set as from 0.4 μm to 0.8 μm with sampling point as 161. This can be found by click the **DFT Spectrum** button in the **Simulate 2D using 64bit simulator** dialog box
- One observation line is put after the grating, it detects the transmission spectrum. Another observation line is put behind the input plane, it detects the reflection spectrum



Please perform the 2D 64bit simulation for this sample layout (32bit simulation is also OK but will be slow). After the simulation, open the results file to get the transmission spectrum and reflection spectrum

Step Action

- 1 Under tools menu, select **Observation Area Analysis**
- 2 Select **Observation Line** in **Observation Area Analysis** dialog box.
- 3 Select "Observationline1" in the observation line check list
- 4 Select **Power Spectrum** button, **Power Spectrum** dialog box appears
- 5 Check "**normalize with**" checkbox and click **Calculate** button, **Power Transmission** spectrum appears, (refer to [Figure 7](#)). Power transmission spectrum matched the measurement results published in the referenced (refer to [Figure 8](#))
- 6 Repeat step 3 to 4 for Observationline2, reflection spectrum can be calculated, (refer to [Figure 9](#)).

Figure 7 Transmission spectrum obtained by OptiFDTD

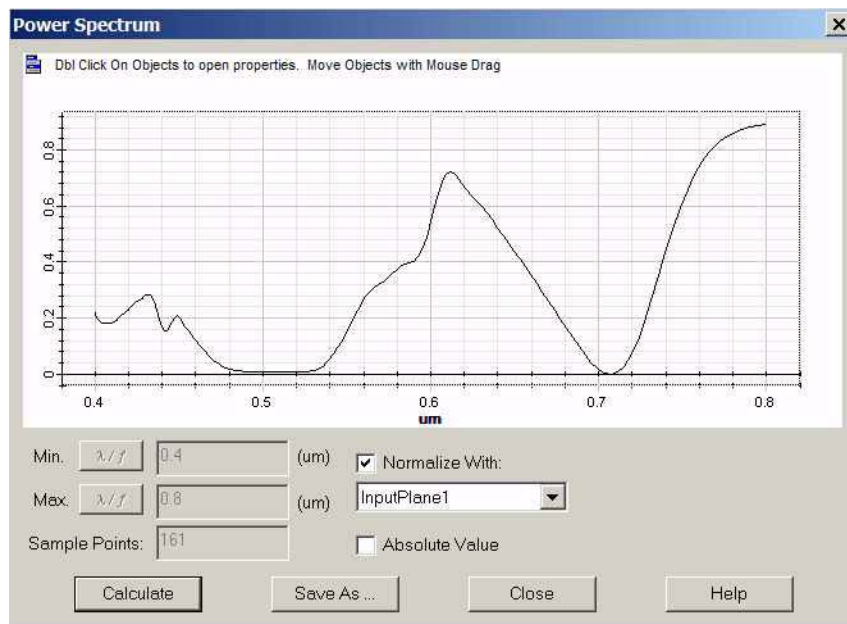


Figure 8 Transmission spectrum in reference [1]

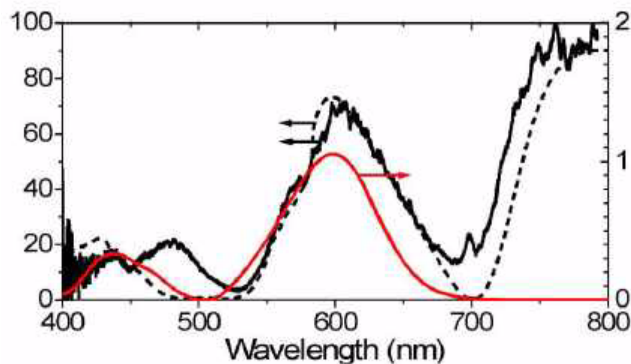
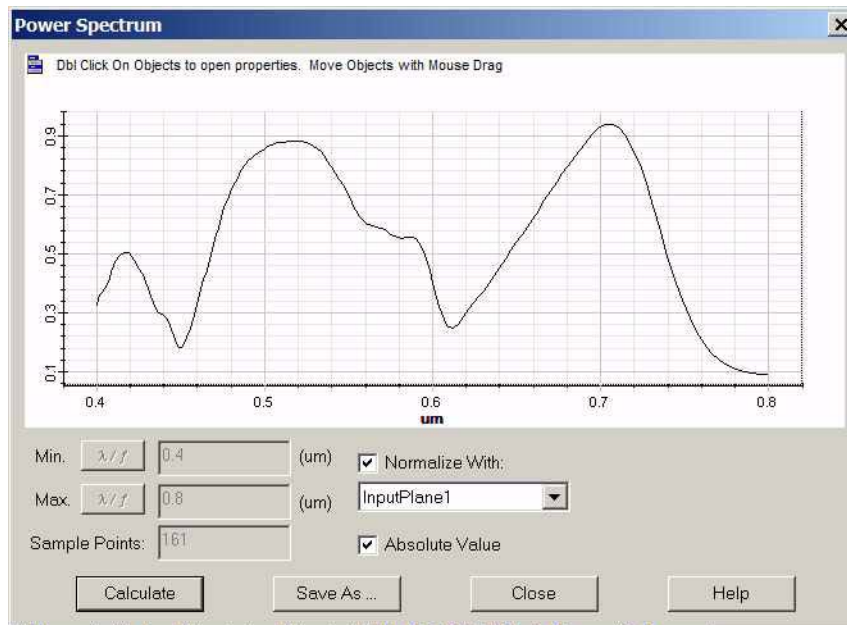


Figure 9 Reflection spectrum obtained from OptiFDTD



Part 3 --- Calculate the diffraction efficiency and diffraction angle based on grating unit cell simulation

This part shows how to extract the diffraction angle and diffraction efficiency based the FDTD near field simulation and far-field transform. The simulation concept is to use the FDTD method to get the near field pattern and near field transmission and reflection. The diffraction angle and power ratio for different diffraction beam can be evaluated from the far-field pattern. Then the power ratio for each diffraction beam multiplies the near field transmission (or reflection) will be the grating efficiency.

The sample used in this part is a 2D periodic grating with both substrate and grooves are made of SiO₂ (n=1.5). Normal incident plane waves come from the air then pass

through the grooves and goes to the substrate. For such a periodic layout with normal incident plane wave, we can still pick up one unit cell to perform the simulation with transverse boundary condition set as PBC. In case of tilting angle input, more periodic cells should be used for the simulation and transverse boundary should be AMPL.

The sample file can be found in the Sample file folder, the file is named as: "X64_sample56_2D_Caululate_Grating_Efficiency.fdt". Please open this layout with OptiFDTD layout designer. Double clicking on each object in the layout to check the settings:

- The periodic length is $1.0\ \mu m$, the groove length is $0.5\ \mu m$, and depth is $0.15\ \mu m$. Substrate layer connects to the z-direction end, which is supposed the transmitted waves are all goes out.
- Time domain input waves is continued, wavelength is $0.63\ \mu m$, for this single wavelength simulation. We can set the input plane wave power as 1.0, then where the power in the observation line is put in the transmission region will be the transmission value.
- X-direction boundary is set as PBC
- An observation line is put after the grating, it detects the near field transmission and the field pattern

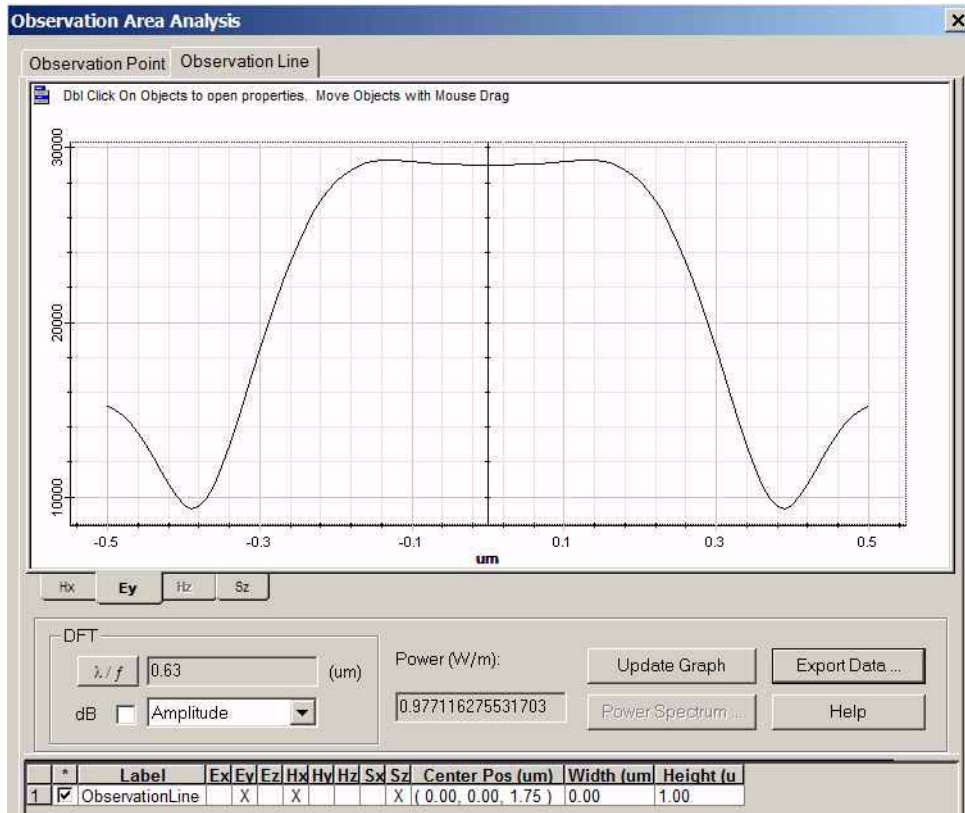
Please perform the 2D 64bit simulation for this sample layout (32bit simulation is also acceptable, but will be slower). After the simulation, open the results file to check the near field properties.

Step Action

- 1** Under **tools** menu, select **Observation Area Analysis**.
- 2** Select **Observation Line** in **Observation Area Analysis** dialog box. Select "Observationline1" in the observation line check list
- 3** Click **Update Graph** button, near field pattern along the observation line and the power value 0.9771162755 appears (refer to [Figure 10](#)). The power value shown here is the power transmission, because the input power is set as 1.0



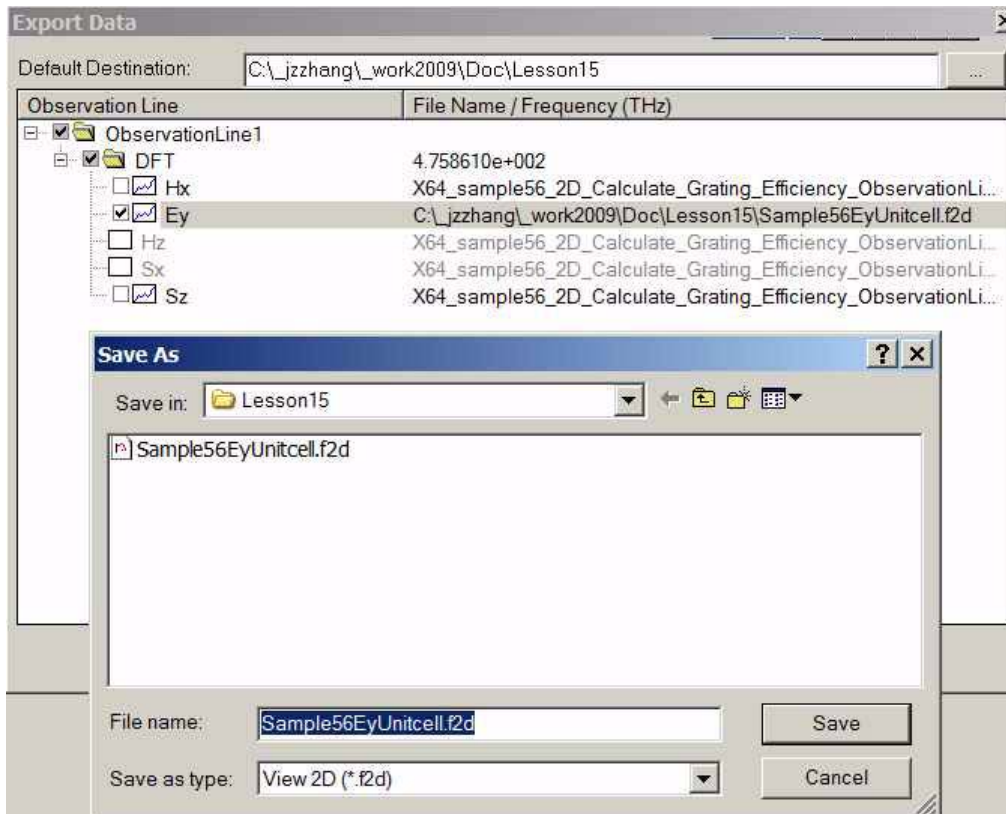
Figure 10 Field pattern in Observation line



- 4 Click **Export Data** button to export the field pattern along the line. The export data dialog box appears. (Refer to Figure 11). Select the **Ey** components, and

then right click this **Ey** component to change the file folder and name. Name the exported data file as “Sample56EyUnitcell.f2d”

Figure 11 Export near field pattern



5 The exported data file is for one periodic cell. Now extend this data for 40 periodic cells so that far field transform will be more accurate. Open the exported field file by using the Notepad or other text editor.

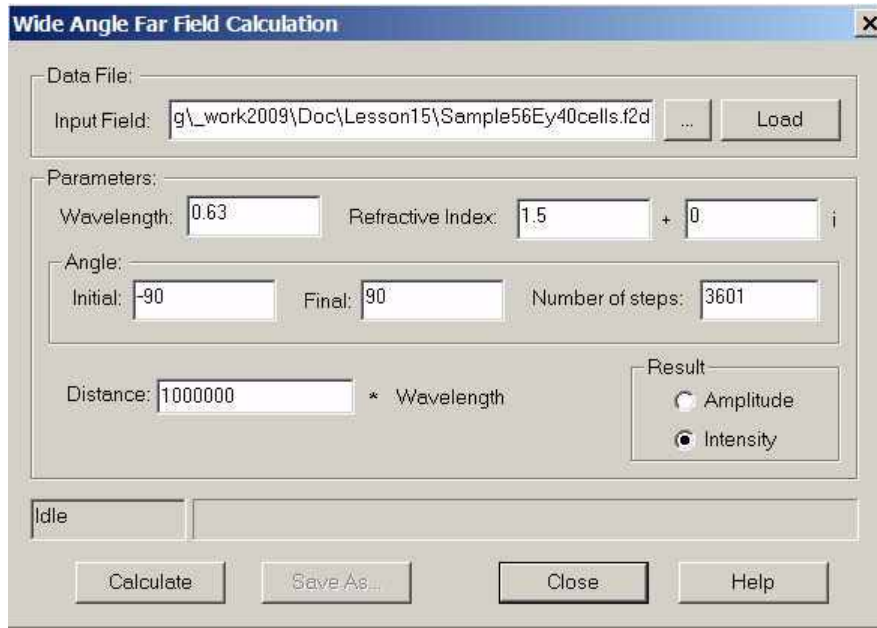
- The first line in the data file is the version number.
- The second line is data point number which is 101.
- The third line is the observation line dimension start value and end value.
- The remaining lines are complex field data.

To extend the field data as for 40 periods, please do the following.

- a Copy the data from fifth line to the end, totaling 100 lines.
- b In the end of data file, paste the copied data 39 times.
- c Change the second line data point number as 4001.
- d Change the third line as -20.0 20.0.
- e Save the new data file as “Sample56Ey40cells.f2d”

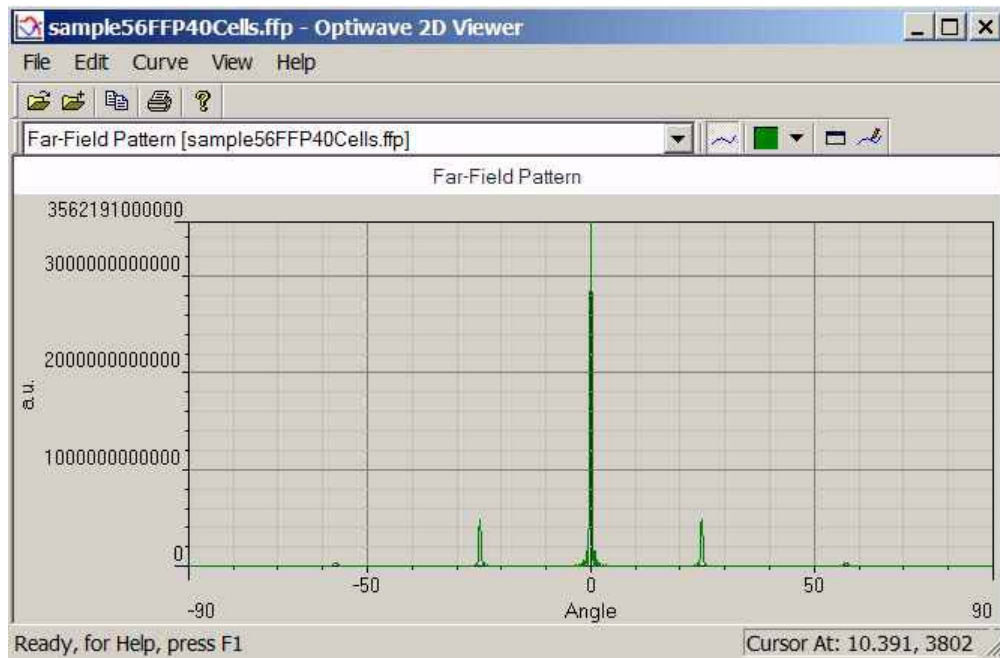
- 6 From the OptiFDTD program start menu, select tools box and select the far field button, then select the “Wide angle far field 2D”, **Wide Angle Far Field Calculation** dialog box appears (refer to [Figure 12](#))

Figure 12 Wide angle far field calculation



- 7 In the “Wide Angle Far Field Calculation” dialog box,
- Click “...”, button to locate the near field file “Sample56Ey40cells.f2d”
 - Click **Load** button to load the data into the calculation
 - Set wavelength as $0.63 \mu m$
 - Set refractive index as 1.5
 - Initial angle: -90degree, final angle: 90Degree, Number of steps: 3601
 - Set results as Intensity
 - Click **Calculate** button and save the results as “sample56FFP40Cells.ffp”
- 8 From the OptiFDTD program start menu, select the “Opti 2D viewer”, then use it to open the far field file “sample56FFP40Cells.ffp” (refer to figure 12)

Figure 13 Far field pattern



- 9 In the Far field pattern, right click the graph and select the zoom in tools to zoom in each peak value, or open the data file by any text editor to read each diffraction angle and peak value

Diffraction order	Angle(Degree)	Peak value
0	0	3.562191e+012
±1	±24.82	4.780688e+011
±2	±57.14	3.998404e+010

- The diffraction angle matched the diffraction equation
- 0th-order power ratio (to the total power) can be evaluated from the peak intensity ratio. i.e.

$$\frac{3.562191e + 012}{(3.562191e + 012 + 2.*4.780688e + 011 + 2.*3.998404e + 010)} = 0.7746$$



- 0th-order diffraction efficiency is power ratio multiply the near field transmission

$$0.7746 * 0.9771 = 0.75686166$$

LESSON 15 - GRATING SIMULATION



Lesson 16 – Calculating Power Transmittance and Reflection using VB Script

OptiFDTD provides comprehensive post-simulation analysis tools. Such as transmittance spectrum analysis, mode overlap calculation, input overlap calculation, far field calculation, Poynting vector analysis, polarized power calculation and so on. These analysis tools were mainly used in the analyzer. Some users may want to perform the sweep simulation and want feedback the results to the layout designer so that the layout can be optimized, or some users may want to get the power transmission/reflection spectrum results without the manipulation of opening the analyzer. Now these works are possible by using the VB script for the 2D layout.

Access to the simulation result data of Observation Objects is a critical feature needed for optimization of the designed devices. Exposure of the available data through the VB Script interface allows for implementation of the basic optimization algorithms within the script and provides the means to access third party solutions supporting COM Automation

OptiFDTD provides the following VB script function based the **Observation Line** Power post-simulation analysis.

10 PowerAtCenterWavelength()

Purpose: Calculates power at the Center Wavelength. The Center Wavelength value is specified at the primary (key) Input Plane. All types of 2D (CW, GMCW) simulations support this function.

11 PowerAtWavelength(double dWavelength)

Arguments:

dWavelength- specifies a wavelength value for which the calculations should be performed. Wavelength value must be greater than zero

Purpose: Calculates power at the specified Wavelength. This function should be used with 2D GMCW simulations. It can be used with 2D CW simulations as well. However, in this case it makes sense only when non-linear materials have been used to construct project components, and one can expect some harmonic frequencies to be generated.

12 CalcPowerSpectrum(dStartWavelength, dEndWavelength, nNumberOfPoints)

Arguments:

dStartWavelength- a double value of the spectrum start wavelength. Its value has to be smaller than the value of End Wavelength argument.

dEndWavelength- a double value of the spectrum end wavelength. Its value has to be greater than the value of Start Wavelength



nNumberOfPoints- an integer value of the number of sampling points within the spectrum. Its value has to be greater than one.

Purpose: Calculates power spectrum for the specified number of wavelength sampling points. This function can be used only with 2D GMCW simulations. When used with other type of simulations, the function will return zero as the power value.

13 GetPowerAtSpectralPoint(nPointIndex)

Arguments:

nPointIndex- an integer value of the spectral point. The points are indexed starting from zero

Purpose: Retrieves a value of previously calculated power at the specified sampling point. The function will return zero if called before the CalcPowerSpectrum() has been executed.

14 CalcNormalizedPowerSpectrum(dStartWavelength, dEndWavelength, nNumberOfPoints, sInputPlaneLabel)

Arguments:

dStartWavelength- a double value of the spectrum start wavelength. Its value has to be smaller than the value of End Wavelength argument.

dEndWavelength- a double value of the spectrum end wavelength. Its value has to be greater than the value of Start Wavelength

nNumberOfPoints- an integer value of the number of sampling points within the spectrum. Its value has to be greater than one.

sInputPlaneLabel- label of the Input Plane, which signal is going to be used for normalization. The Input Plane with the specified label must be one of the active ones generating GMCW signal.

Purpose: Calculates power spectrum normalized to the power signal of the specified Input Plane, for the specified number of wavelength sampling points. This function can be used only with 2D GMCW simulations. When used with other type of simulations, the function will return zero as the power value.

Note: Normalization is calculated against an existing, active Input Plane. The Input Plane must generate GMCW signal.

15 GetNormalizedPowerAtSpectralPoint(nPointIndex)

Arguments:

nPointIndex- an integer value of the spectral point. The points are indexed starting from zero

Purpose: Retrieves a value of previously calculated power at the specified sampling point. The function will return zero if called before the CalcNormalizedPowerSpectrum() has been executed.



Note: For more detail on this function, please refer to the *VB Script Reference* manual.

OptiFDTD provides a template in a sample file to show you how to use these functions. Users are encouraged to copy this template as their own project. The template sample can be found in the sample folder: **Sample36_VBS_ToGet_Power_Spectrum.FDT**

The following demonstrates these functions.

Step Action

- 1 In the OptiFDTD Sample folder, open **Sample36_2D_TE_VBS_PowerSpectrum.FDT** in the Waveguide Layout Designer.
- 2 Double-click on the Input Plane to check the 2D input wave settings.
- 3 Select all the objects in the layout, then click “**Delete**” key to delete all the objects
- 4 Click “ **Test Script**” shortcut toolbar or select “ **Test Script**” in the Simulation menu

Now all the objects in the layout are recreated by VB script.

- 5 Click the **Scripting** tab to go to the Script page.
- 6 This layout is designed by VB script. In the Scripting page, the first 110 lines is the VB code to generate the layout. After the first 110 lines, it is the code to get the power transmittance and reflection. A VB subroutine is designed which contained the above VB function. The user can just copy the subroutine to their own design to get the corresponding power or power transmittance value.
- 7 Save this layout to a different folder.
Note: You can change the project name
- 8 Select “**Simulation 2D using Script**” to start the simulation.
- 9 After the simulation, you will find that the following result files are exported from the VB function.

Sample36_2D_TE_VBS_Power_Spectrum_NormalizedPowerSpectrum.txt
Sample36_2D_TE_VBS_Power_Spectrum_PowerAtCenterWavelength.txt
Sample36_2D_TE_VBS_Power_Spectrum_PowerAtWavelength.txt
Sample36_2D_TE_VBS_Power_Spectrum_PowerSpectrum.txt

Note: Each file contains the results for two Observation lines due to the fact that the VB Script function called the spectrum calculation for each observation line.

NOTES:



Lesson 17 - Analysis of Photonic Crystal Fibers (PCF) in OptiFDTD

Introduction

In the past 10 years, photonic crystal fibers (PCF) have attracted much scientific and commercial interest. The research and design work for PCF starts from accurate modal analysis of the fiber. Once the modes are found, all of the PCF properties such as loss, dispersion, and cutoff can be determined.

There are general three types of PCF: holey fiber (HF), field-confined holey fiber (FCHF) and Hole-Assisted Light-guide Fiber (HALF), as shown in figure 1.

In OptiFDTD, the mode solver is combined with the FDTD engine so that FDTD simulation can use the modal field as input directly. In addition to this integrated mode solver, OptiFDTD also provides an independent mode solver to allow user to solve and study the modal solutions outside of an FDTD calculation. The PCF mode solver will mainly be used as an independent mode solver. Modal analysis requires two main steps:

- a. Create the layout representing a PCF
- b. Calculate the modes

We will use our Waveguide Layout Designer to define the PCF layout, and then convert the layout to a refractive index distribution file. The mode solver will load-in the index distribution file and perform the modal analysis.

Some users may want to scan the wavelength to find out the cutoff wavelength, or scan the layout parameters. All of this is possible with OptiFDTD package.

The following section will demonstrate how a photonic crystal fiber can be analyzed in OptiFDTD.

Sample 1- Photonic Crystal Fiber-Holey Fiber

The most common PCF is Holey Fiber as shown in [Figure 1](#), the cladding region consists of a hexagonal array of air holes; One missing air-hole defines the core region. The real layout may have more layers of air holes, but it is sufficient to model only three layers since the mode is well confined ^[2]. To be safe, here we take five layers for the mode solving. We use the PBG array editor to define the hexagonal air hole. To make the core center in the simulation domain's center, we need to draw a graph (see [Figure 2](#)) so that the detail dimension information can be marked. Such a graph can make the layout creation easier, so it is highly recommended.

Figure 1 Photonic Crystal Fiber cross-section

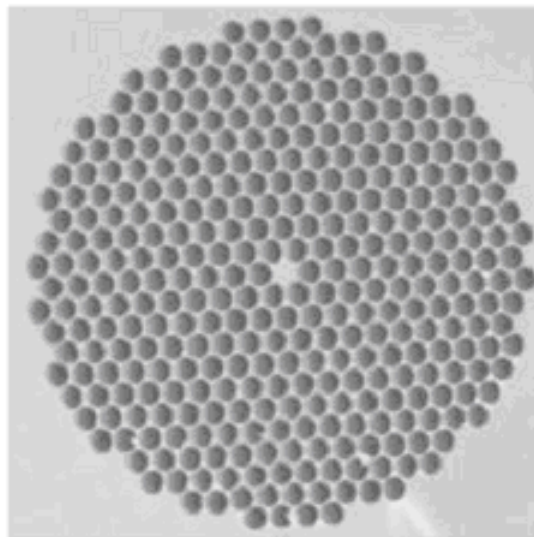
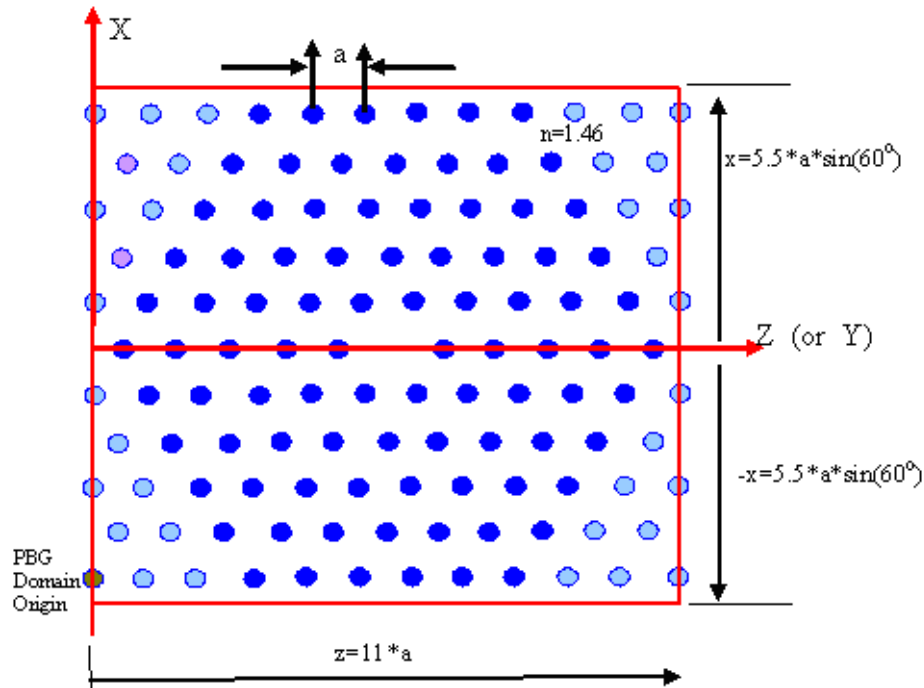


Figure 2 Five layers holey fiber



Please note:

For this five layer holey fiber

- (a) The background material refractive index $n = 1.46$
- (b) Hexagonal Air hole, periodic: $a = 2.3\mu\text{m}$, $n = 1.0$, radius $R = 0.6\mu\text{m}$
- (c) Simulation domain: $z = 11*a$, $x = 11*a*\sin(60^\circ)$
- (d) The green dot is the hexagonal lattice original point: $x = -5*a*\sin(60^\circ)$; $z = 0$

Create the layout

To design a holey fiber structure, follow these steps.

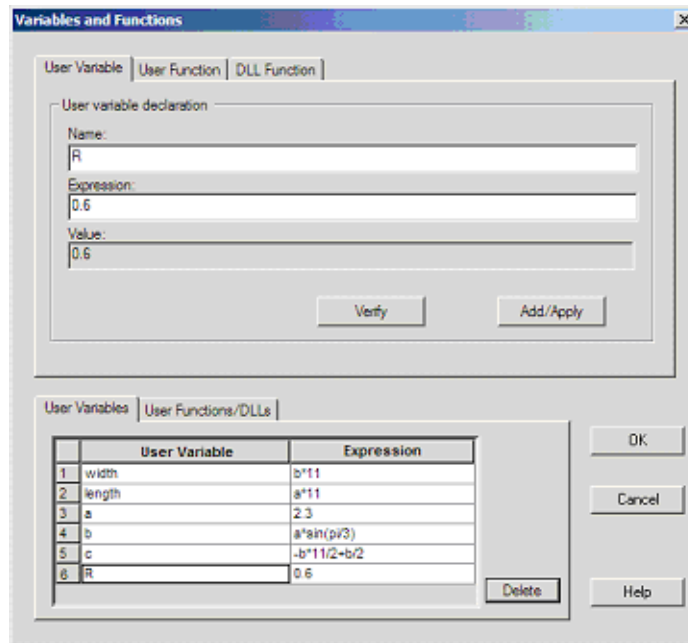
- | Step | Action |
|------|--|
| 1 | Start Waveguide Layout Designer . |
| 2 | To create a new project, select File > New .
<i>The Initial Properties dialog box appears.</i> |

- 3 Click **Profiles and Materials**.
*The **Profile Designer** window appears.*
- 4 Under the **Materials** folder, right-click the **Dielectric** folder and select **New**.
*A new **Dielectric material dialog box** appears.*
- 5 Type the following information:
Name: **n=1.46**
Refractive index (Re:): 1.46
- 6 To save the material, click **Store**.
N=1.46 appears in the **Dielectric** folder in the directory and in the dialog box title bar.
- 7 Under the **Profiles** folder, right-click the **Channel** folder and select **New**.
*The **ChannelPro1 dialog box** appears.*
- 8 Create the following channel profile:
Profile name: **Channel_Air**
2D profile definition
Material: **Air**
- 9 Click **Store**.
(Close the **Profile Designer**.or leave it open)
- 10 Switch to the Layout Designer, and in the **Initial Properties** dialog box type/select the following:
Waveguide Properties
Width [μm]: **0.6**
Profile: **Channel_Air**
Wafer Dimensions
Length: **length**
Width: **width**
2D Wafer Properties
Material: **n=1.46**
- 11 Click **OK** in the initial dialog box. Click **Yes** in the question dialog box to start define the variables. [Variables and Functions dialog box appears](#)
Because variable (length, width) is used in the initial dialog box .clicking OK will open the Parameter Editor dialog box
- 12 In the **Variables and Functions** dialog box, define the following variables in the specified order then click **OK** to close the dialog box

Name	value	
a	2.3um	~lattice constant
b	$a \cdot \sin(\pi/3)$	~height of triangle cell
length	11*a	~length of domain
width	11*b	~width of domain
c	-5*b	~X original point of lattice
R	0.6um	~Radius of air hole



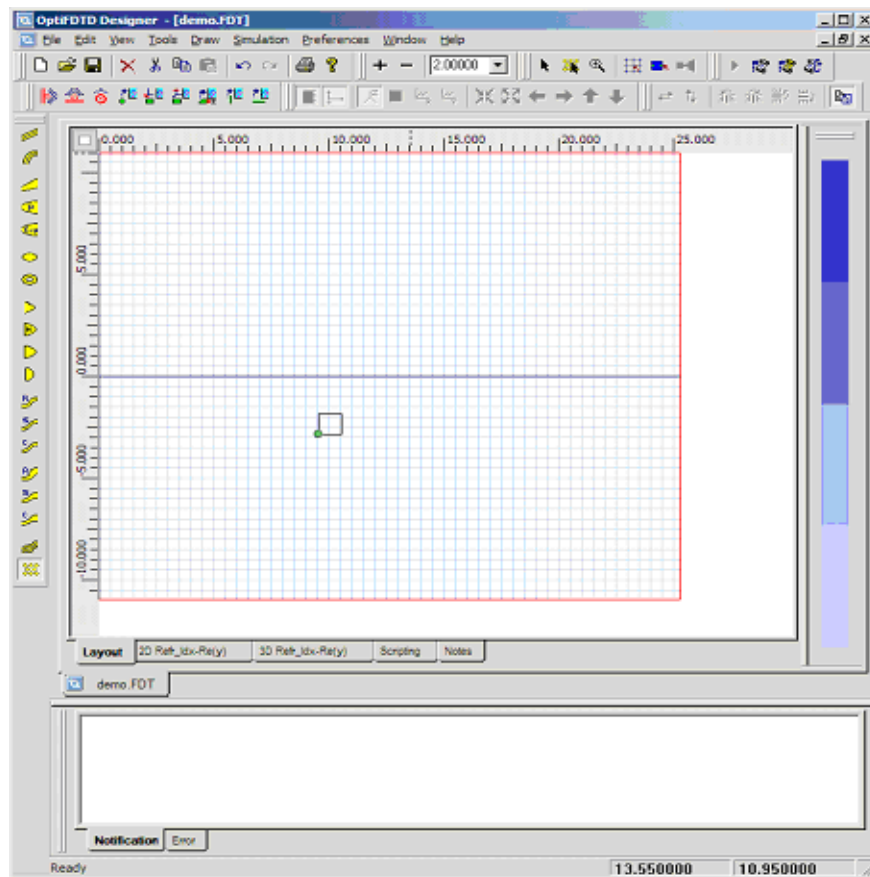
Figure 3 Variable and function dialog box



Note: you can access **Variables and Functions** dialog box at any time by selecting “**Simulations->Edit Parameters**” menu of Layout Designer

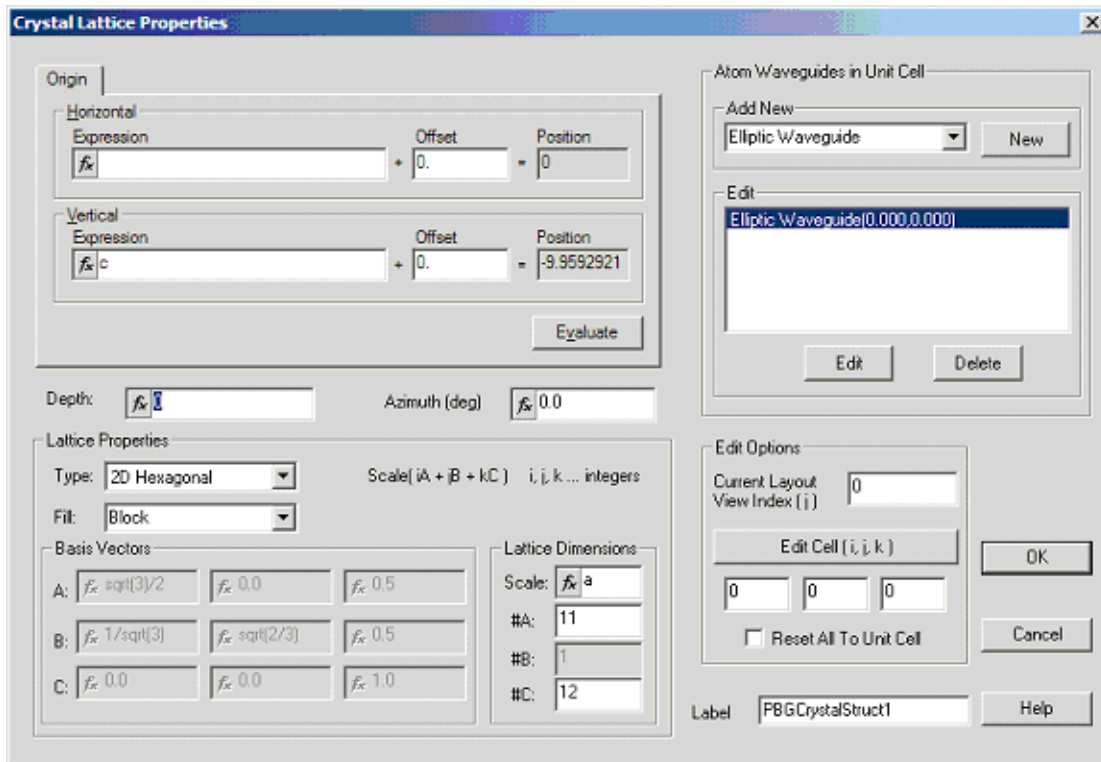
- 13 From the **Draw** menu, select **PBG Crystal Structure**.
- 14 With the mouse cursor click once on the layout window, *The **PBG Crystal Structure** appears in the layout window (see Figure 4)*. Click Select tool button (the arrow) on the shortcut toolbar to release the PBG selection.

Figure 4 Layout window with initial PBG layout



- 15 To edit the crystal structure, double-click on the PBG structure (a rectangular shape) on the layout. The **Crystal Lattice Properties** dialog box appears (Figure 5).

Figure 5 Crystal Lattice properties dialog box



16 In the Crystal Lattice Properties dialog box, Set the following parameters

Origin

Horizontal, expression:0

Horizontal Offset:0

Vertical Expression:c

Vertical Offset:0

Depth: 0.0

Azimuth: 0.0

Lattice Properties:

Type: 2D Hexagonal

Fill: Block

Lattice Dimension:

Scale: a

#A: 11

#C: 12



- 17 In **Atom Waveguide in Unit Cell, Add New**, select **Elliptic Waveguide** from the drop-down menu and click **New**. The ***Elliptic Waveguide Properties** dialog box* appears (see [Figure 6](#)). In ***Elliptic Waveguide Properties** dialog box* set following value

In **Center, Offset**, type/select the following:

Horizontal: **0.0**

Vertical: **0.0**

Type/select the following:

Major radius: **0.6**

Minor radius: **0.6**

Orientation angle: **0.0**

Channel thickness tapering: **Use Default (Channel: None)**

Depth: **0.0**

Label: **Atom**

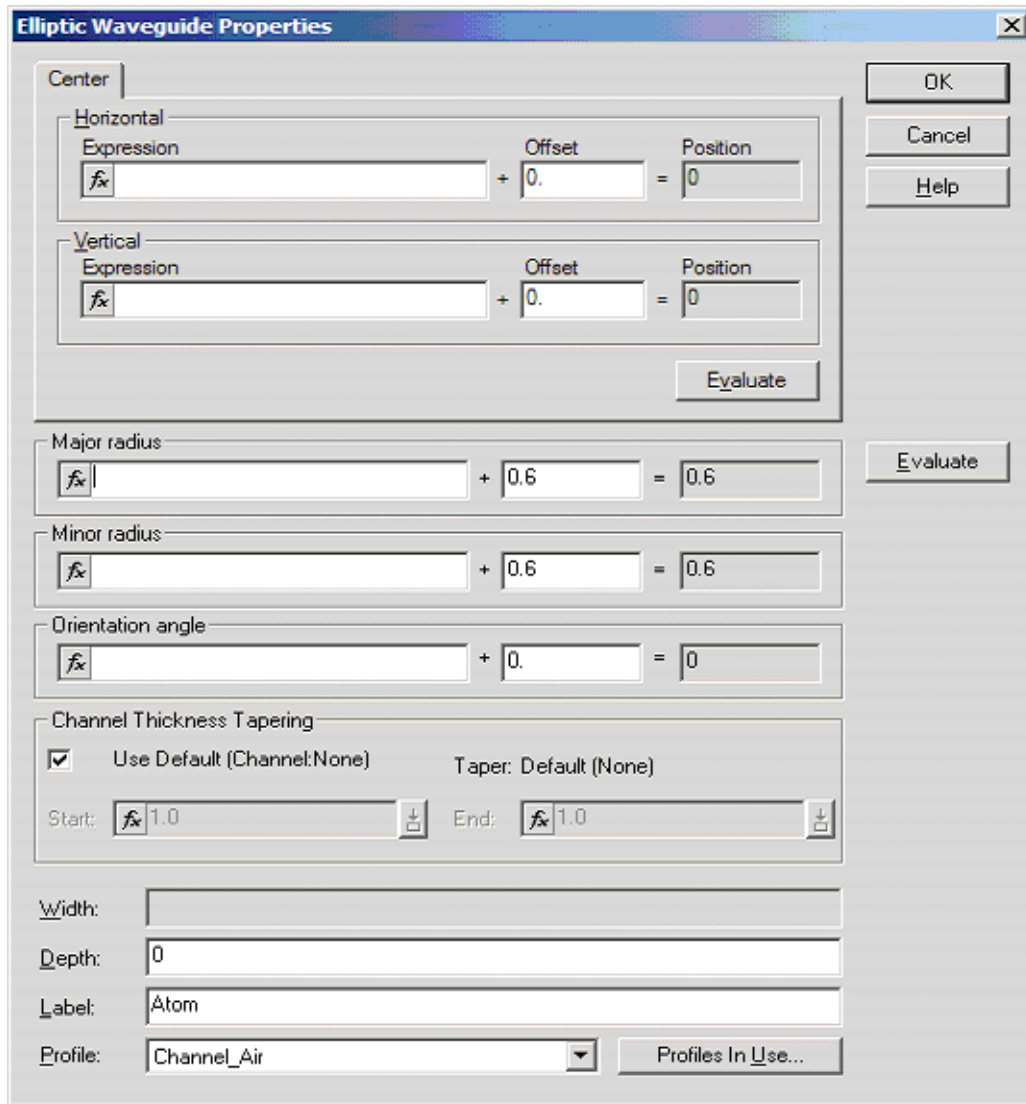
Profile: **Channel_Air**.

Click **OK**.

The **Elliptic Waveguide Properties** dialog box closes.



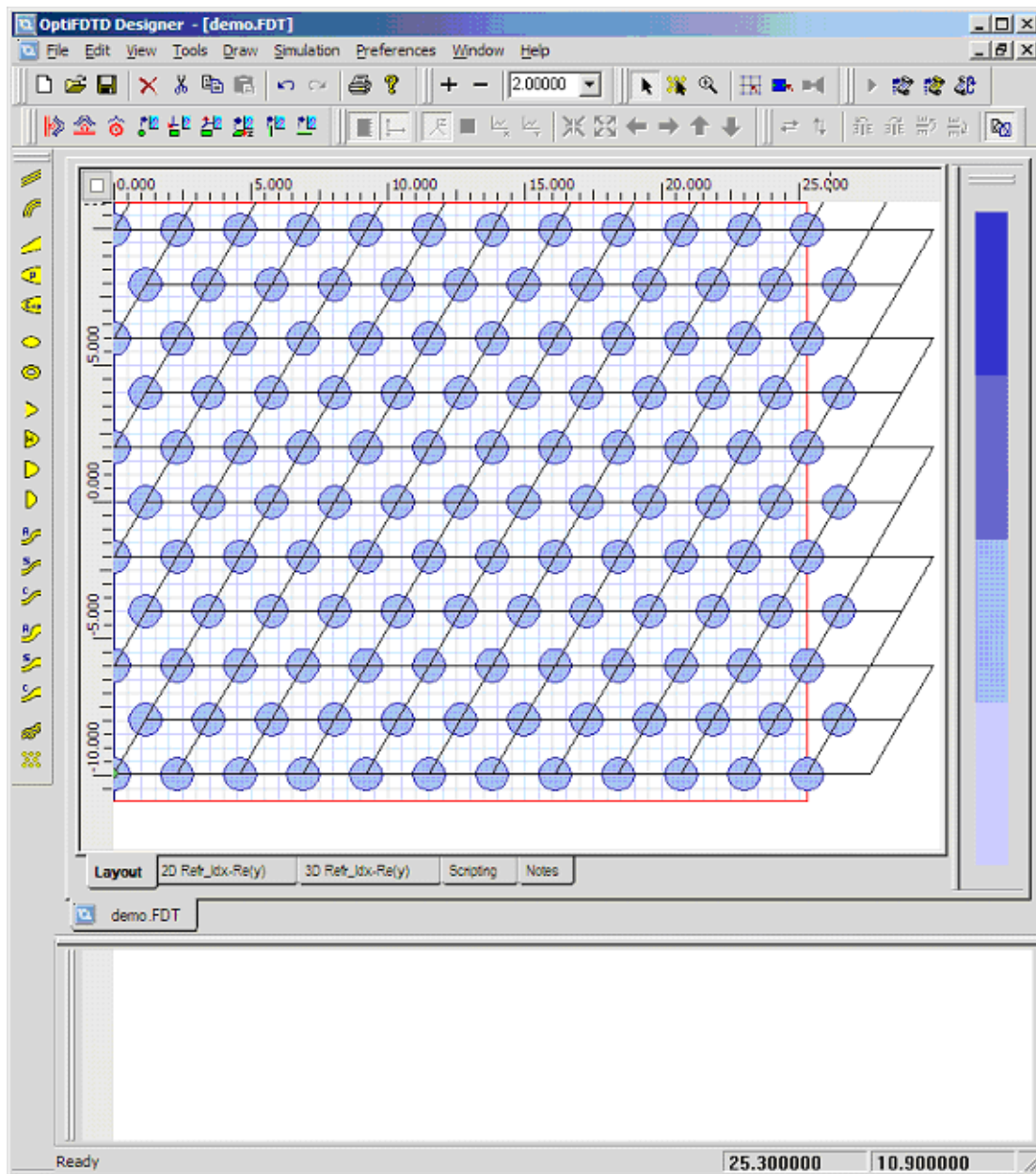
Figure 6 Elliptic Waveguide Properties dialog box



Note: When you return to the **Crystal Lattice Properties** dialog box, you will see the defined elliptic waveguide listed in **Atom Waveguide in Unit Cell**.

Note: If you close the **Crystal Lattice Properties** dialog box, you will see the defined PBG structure in the layout window (see [Figure 7](#)).

Figure 7 PBG layout in designer window

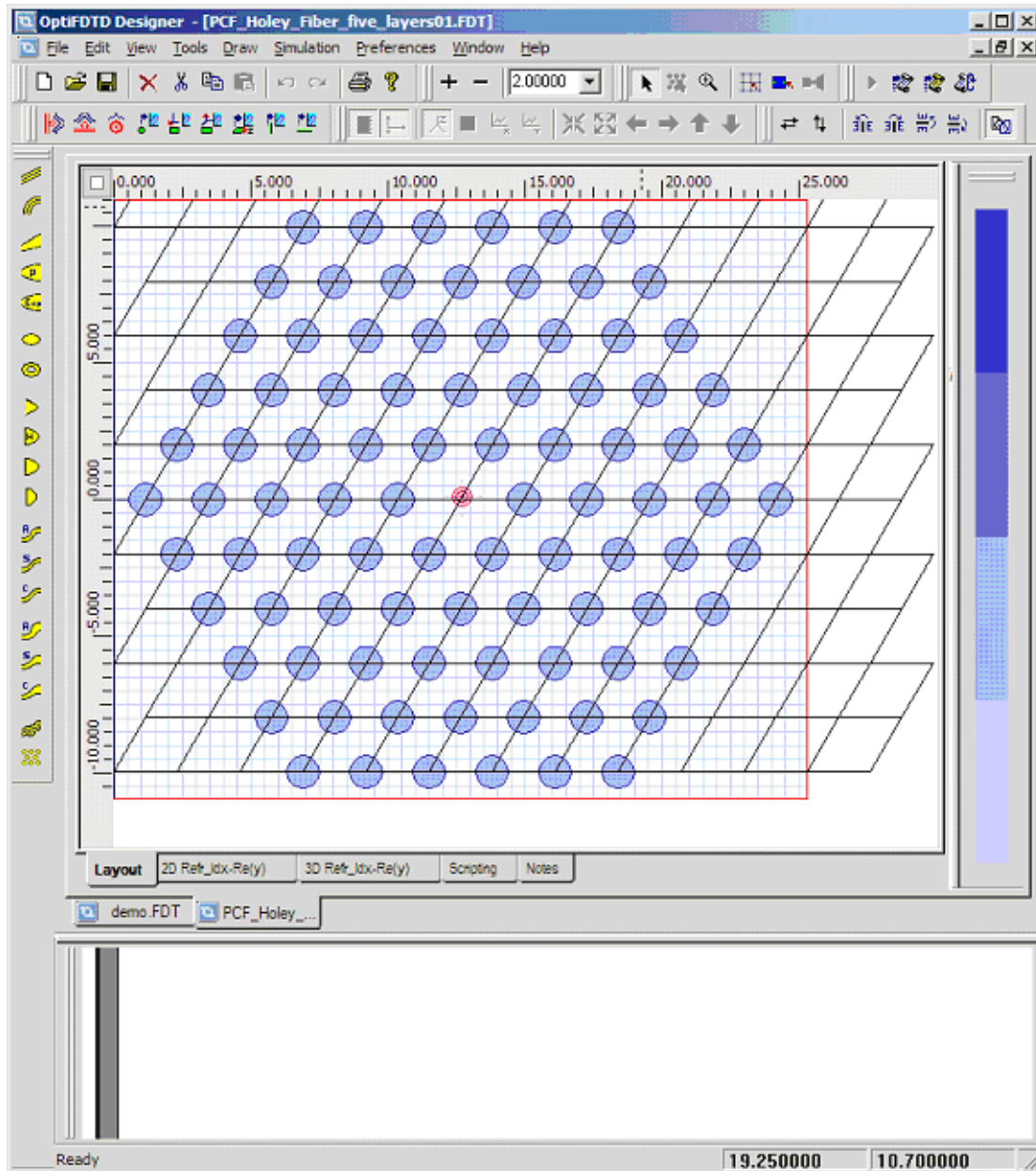


- 18 In the layout designer, to select the PBG lattice, click the PBG area. The **PBG Crystal Structure Cell Editing Tool** (a shortcut toolbar beside the Arrow select tool as shown in figure 8) becomes active. Select this shortcut tool bar. When this tool is selected, right click on the photonic cell and click “Cells Off” to disable the cells. With this step, a five layer Holey fiber can be realized (see Figure 9).

Figure 8 Shortcut toolbar button of "PBG Crystal Structure Cell Editing Tool"



Figure 9 Five layers holey fiber

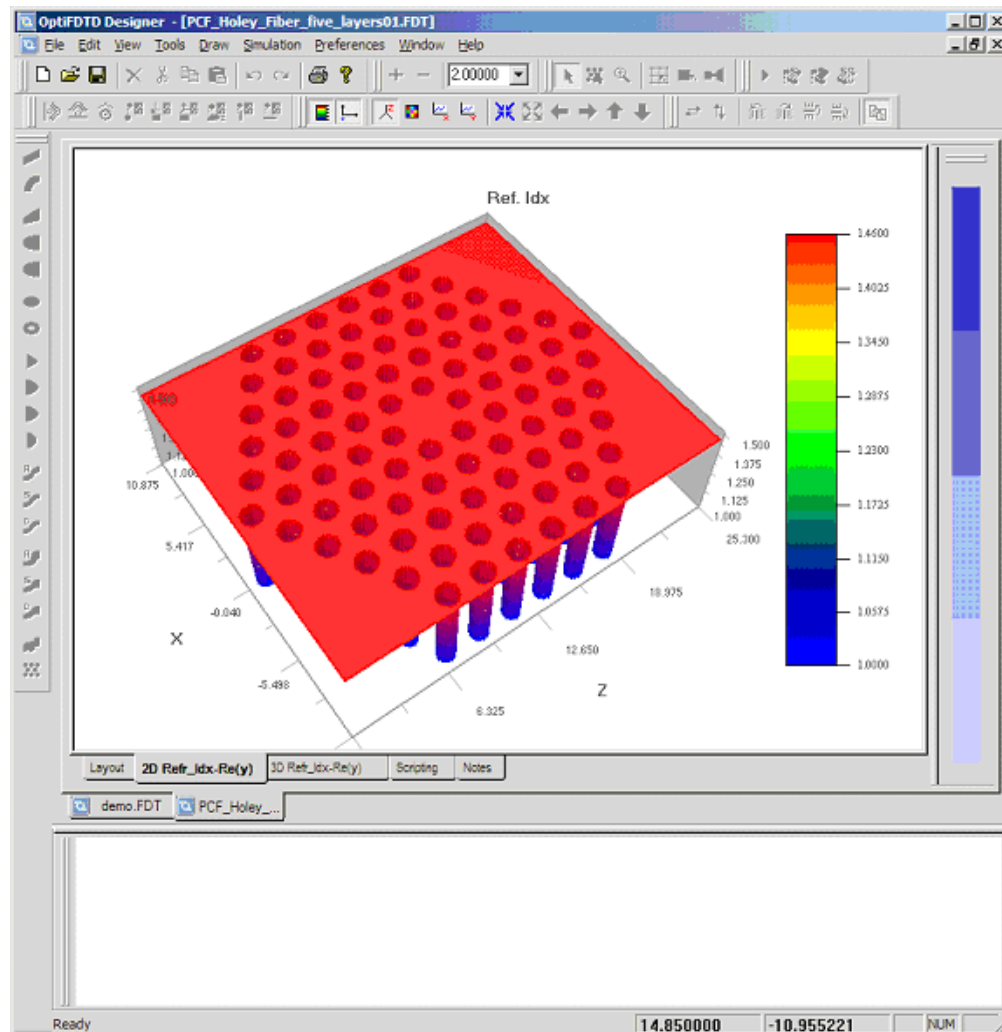


LESSON 17 - ANALYSIS OF PHOTONIC CRYSTAL FIBERS (PCF) IN OPTIFDTD

- 19 To observe the index distribution, please set a point source in the layout. The center **Wavelength** is 1.3um with Gaussian **Modulated Continuous Wave** as time domain waveform
- 20 Click **2D Simulation Parameters** under **Simulation** menu, set following parameters and Click OK.

Mesh Delta X: 0.08um
Mesh Delta Z: 0.08um
Run for 1 time steps
- 21 Click "**2D Refr_Idx_Re(y)**" tab under the layout window to observe the refractive index distribution. (see [Figure 10](#))

Figure 10 Refractive index distribution

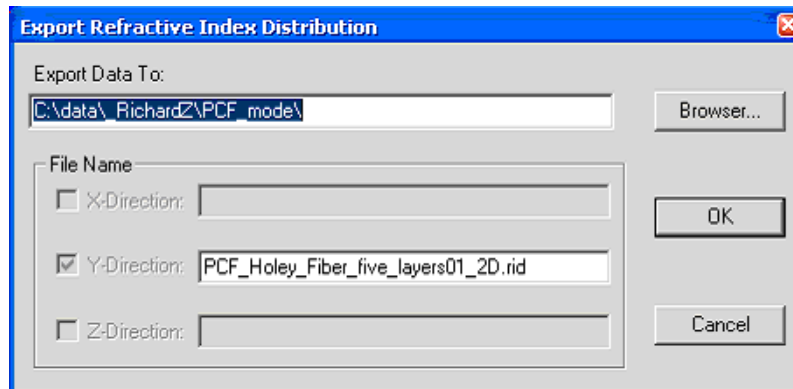


Convert Refractive index distribution to a file

To perform modal calculations we will use the stand-alone Mode Solver application. We need to export the refractive index distribution of the PCF cross-section and transfer it to the Mode Solver. To export the refractive index, follow these steps:

- | Step | Action |
|------|---|
| 1 | Set an input wave (with Gaussian Modulated Continuous Wave as time domain waveform) in the layout, (This work was done in step 18 in a previous section) |
| 2 | Set proper mesh size for mode solving (This work was done in step 19 in a previous section) |
| 3 | Click “2D Refr_Idx_Re(y)” tab to observe the refractive index distribution. (see figure 10) |
| 4 | Select “File->Export Refractive Index Distribution” menu, Export Refractive Index Distribution dialog box appears (see Figure 11) |

Figure 11 Export refractive index dialog box

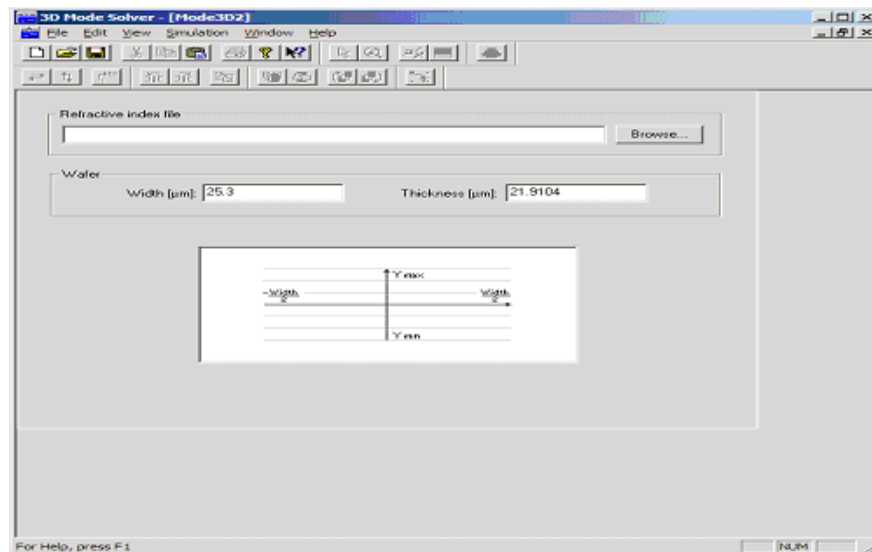


- 5 Click OK, the refractive index distribution will be saved to a file called PCF_Holey_Fiber_five_layers01_2D.riid

Perform the Modal analysis

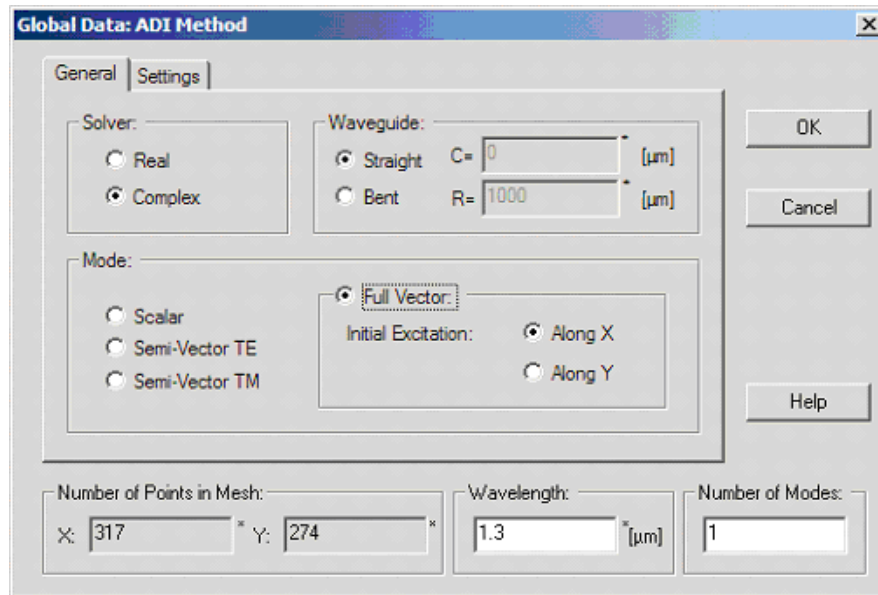
- | Step | Action |
|------|--|
| 1 | Open the stand-alone 3D Mode Solver from Tools: from the Start menu, select Programs > Optiwave Software > OptiFDTD 6.0 > Tools > Mode 3D . <i>3D Mode Solver</i> appears (see Figure 12) |

Figure 12 3D Mode Solver



- 2 Click "**File->New**" menu, select "**User Defined File**" and click OK in the pop up window.
- 3 Click **Browse** button to load the previously exported refractive index file ([PCF_Holey_Fiber_five_layers01_2D.rid](#)--- in this tutorial)
- 4 Click **Simulation** menu and select **ADI Method** under **Global Parameters**. **Global Data:ADI Method** dialog appears (see [Figure 13](#))

Figure 13 Global data: ADI Method dialog box



- 5 In the **Global Data: ADI Method** dialog box, enter the following values, then click **OK** button to accept settings and close the dialog box

Wavelength: 1.3um

Number of Modes: 1

General:

Solver: Complex

Mode: **Full Vector**

Initial Excitation: Along X

Waveguide: Straight

Setting:

Start Field: Gaussian

Accuracy:

Index Tolerance: 1E-007

Field Tolerance: 1E-005

Boundary Condition: TBC

Note: Other setting leave as specified by default

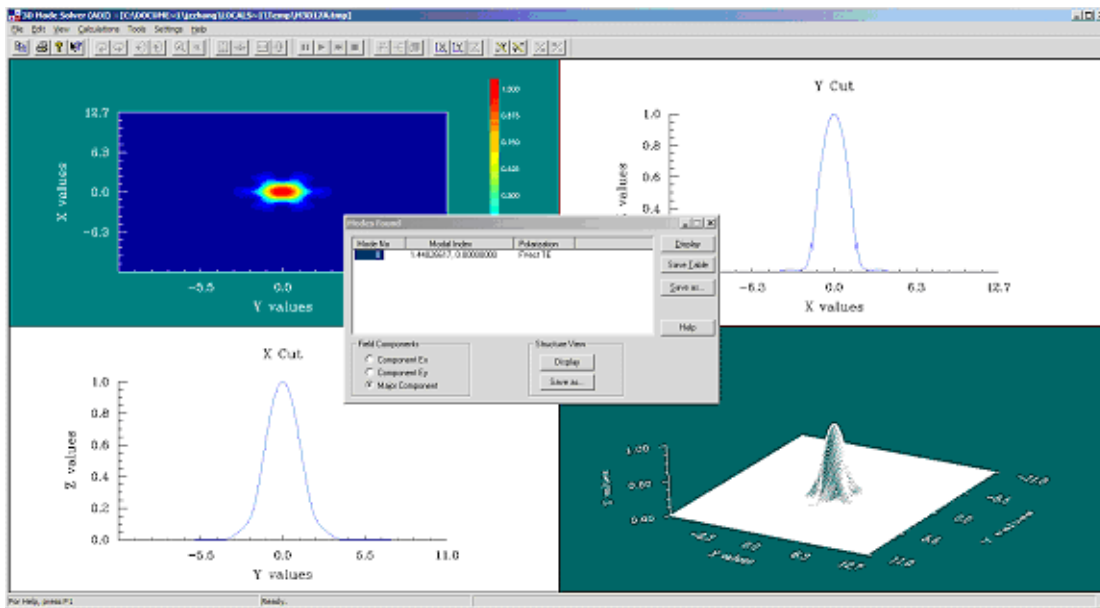
- 6 Select **“Calculate ADI”** under simulation menu. Click **Run** button to start the modal analysis. 3D mode solver resulting window appears (see [Figure 14](#)).

First, the refractive index distribution is displayed. Once the mode is solved (it takes a while), the view will change and display the modal field. (Clicking **Display** under **Structure View** will display the refractive index distribution structure again)

Note: :

- Save the field pattern by click **Save As** button
- Save the modal index by click **“Save Table”**
- Click **Close** in the file menu to close this window

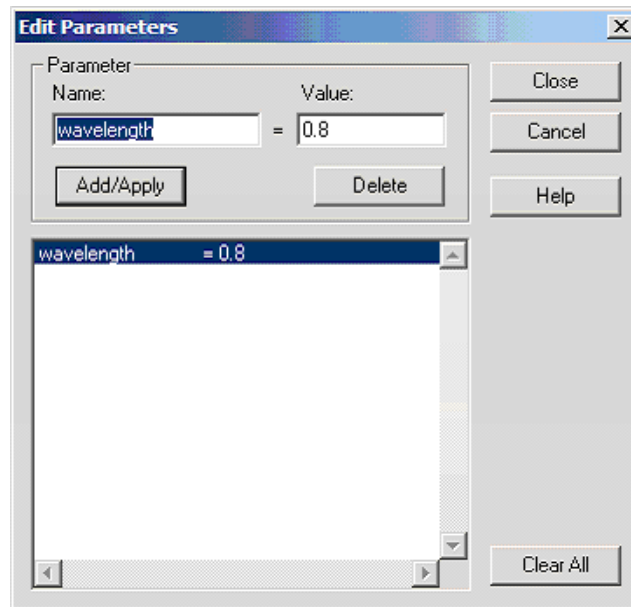
Figure 14 3D mode solver results window



Perform the wavelength scanning mode analysis

- Step Action**
- 1 In the **3D Mode Solver** Window, click **Edit Parameters** under **Simulation** menu. **Edit Parameter** dialog box appears (see [Figure 15](#)).

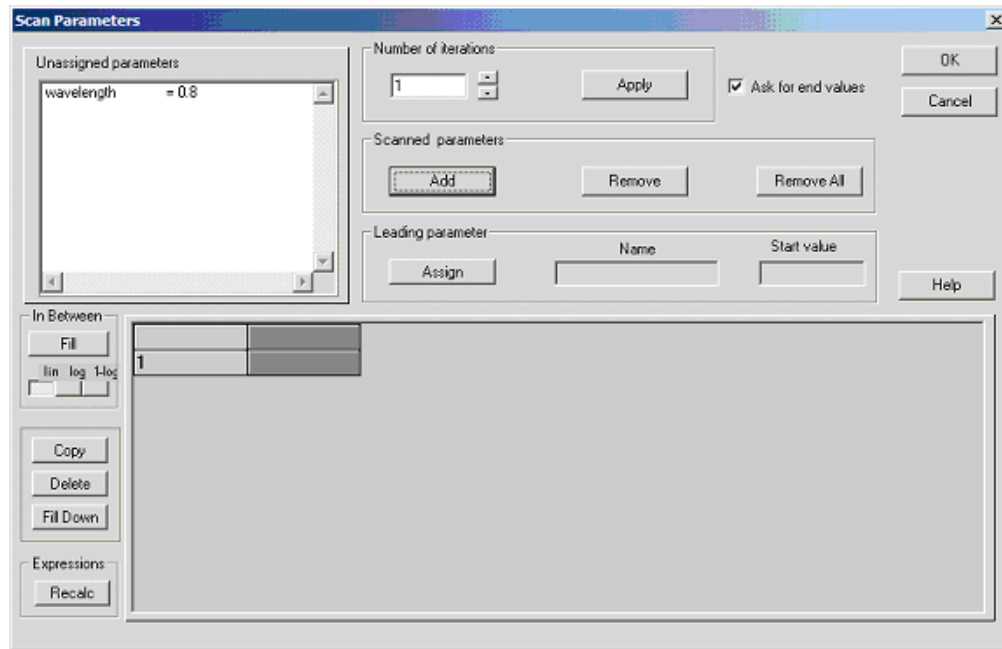
Figure 15 Edit Parameters dialog box



- 2 In the **Edit Parameter** dialog box, **Name** field, enter “**wavelength**” and set its **Value** as **0.8**, Click **Add/Apply** button to make the defined variable to be listed. Click **Close** to close the dialog box
- 3 Click **Scan Parameters** under **Simulation** menu. **Scan parameters** dialog box appears (see [Figure 16](#)).



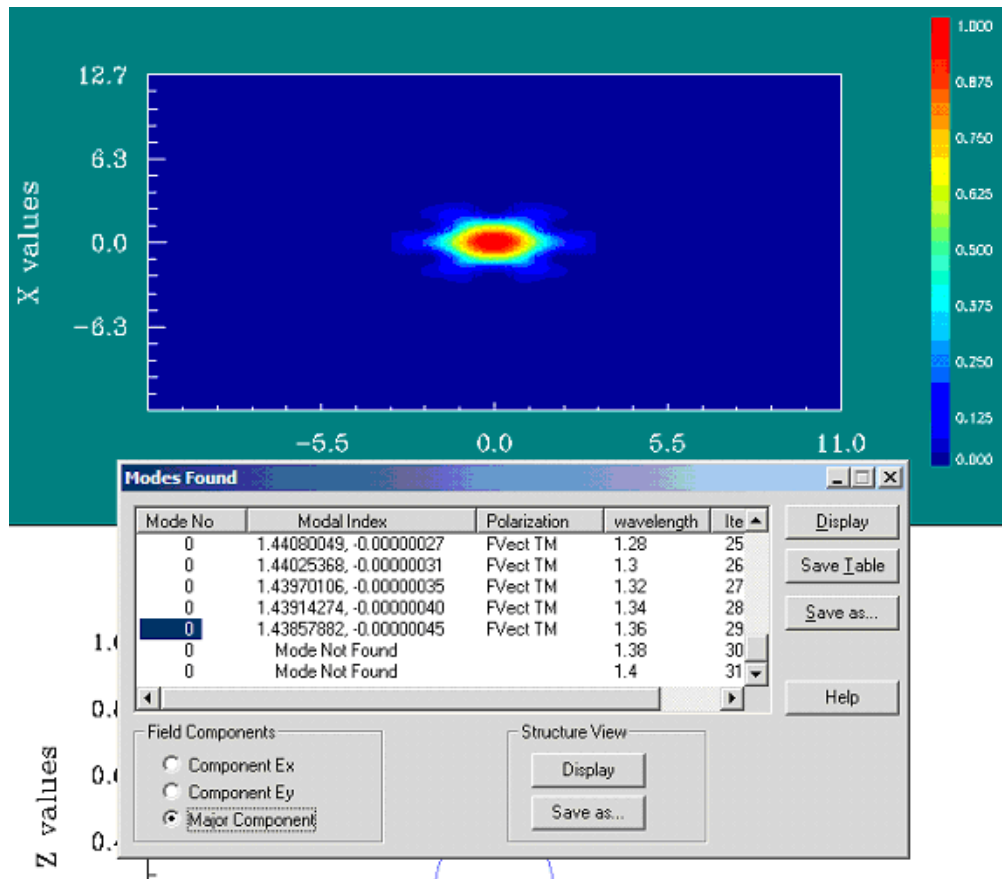
Figure 16 Scan Parameters dialog box



- 4 Select “wavelength” under **Unassigned Parameters** table, Click Add button to add variable wavelength as the scan parameter. Parameter “wavelength” will be listed in the bottom table.
- 5 Set **Number of Iteration** as 31 and click **Apply** button. The table will extend to 31 lines.
- 6 Click **Assign** button in the “Leading parameter” section, our “wavelength” will be set as **Leading Parameter**
- 7 In the table grid, click “wavelength”, the whole column will be selected. inscroll to the line 31, Double click its edit cell and input iteration **End Value** of 1.4
- 8 Re-select the wavelength column and click **Fill** button. The data cells in the column will automatically be filled with the sampling points for each simulation sweep of the “wavelength” value.
- 9 Click **OK** to close this **Scan Parameter** dialog box
- 10 Select “**Simulations->Calculate ADI**” menu. In the Wavelength box enter the previously specified parameter name “wavelength”, select **Full vector** with **initial excitation along Y**. Set **Complex Solver** with **TBC** boundary conditions. Run the simulations
- 11 The Mode Solver will perform a set of modal calculations sweeping the wavelength value. This approach is used to obtain the cutoff wavelength (see [Figure 17](#))



Figure 17 Monitor the wavelength scan simulation



NOTES:



Lesson 18 - Simulations with 64-bit 3D Simulator

The workflow required to perform simulations with 64-bit 3D Simulator is almost the same as for the “regular” 32-bit simulator(s):

- | Step | Action |
|-------------|--|
| 1 | Create a New Layout <ol style="list-style-type: none"> a. Define the material and waveguide in profile designer b. Set up the initial simulation domain c. Draw the waveguide |
| 2 | Define simulation parameters |
| 3 | Define input wave <ol style="list-style-type: none"> a. Set up time domain input b. Set up the transverse domain input |
| 4 | Observe the refractive Index |
| 5 | Set up the Observation Objects (data-detectors) to extract the field pattern and transmission/Reflection spectrum. |
| 6 | Launch 64-bit 3D Simulator (menu “Simulation->Simulate 3D using 64-bit Simulator...”). |
| 7 | Perform the post-simulation analysis |

The 64-bit simulator differs from 32-bit mainly in the aspect of DFT calculations. The 32-bit simulators perform DFT calculations and time domain data are stored for the whole volume. However, the calculation domain of the 64-bit simulator can occupy TB (Tera Bytes) of computer memory. In this case, the amount of generated data would be enormous, which would be impractical and unmanageable. To resolve this issue, the DFT calculations are performed only for the Observation Areas, and time domain data are collected only for Observation Points.

You can configure the DFT settings in Simulation Parameters for 3D 64-bit Simulations. When you choose menu option “Simulation->Simulate 3D using 64-bit Simulator...” you will be presented with “3D Simulation Parameters” dialog box specific for the 64-bit simulator. OptiFDTD provides default configuration of Spectral DFT settings. See User Reference manual for description.

Note:

Performance of simulations on multiprocessor (multi-core) computers.

In order to achieve the highest performance (speed) of the simulation, it is recommended that the computer is not used while the simulations are in progress:

The calculations are performed on all available processors in so called true-parallel algorithm (the only applicable parallel processing method for

FDTD algorithm). In result the overall performance (speed) of the simulations depends on the processing speed of the slowest processor, since all other processors have to wait until the last processor completes its simulation sequence.

If the computer is used for other tasks during the simulations, the operating system will take some CPU time to support the user running his application (e.g. email, internet browser, word editors, etc.). It will decrease the CPU time spent by one (or more) of the processors on simulations.

DFT Calculations.

When performing simulations with 64-bit Simulator, make sure that the designed project has Observation Objects (Areas or Points) defined. Otherwise, the simulation results will not be stored for the post-simulation analysis.

All 32-bit simulators are also available under 64-bit machine. However, their memory usage is still limited to 2GB.

Create a new Layout

The following lesson uses straight channel waveguide as an example.

Note:

- The corresponding project file can be found in the **Sample** file folder, **Sample43_64bit_3D_Simulations_Getting_Started.fdt**.
- If you already familiar with layout creation, please open the example project and go to the step "Perform the 64Bit-FDTD FDTD Simulation"
- Please see other tutorial lessons to get familiar with the Layout Designer features

Layout creation steps

- | Step | Action |
|-------------|---|
| 1 | Open OptiFDTD Waveguide layout Designer
From the Start menu, select Programs > Optiwave Software > OptiFDTD > Waveguide Layout Designer . OptiFDTD_Designer window opens |
| 2 | Create a new project
From the OptiFDTD_Designer File menu, select New . <i>The Initial Properties dialog box appears</i> |
| 3 | Define the material(s) and waveguide profile(s) that will be used in the project
Click Profiles and Materials button in the area in Initial Properties Dialog. The Profile Designer OptiFDTD opens,

Note: Profile Designer can also be opened independently at any time |
| a. | In the directory under OptiFDTD_Designer1 of Profile Designer OptiFDTD , under Materials folder, right-click the Dielectric folder. A <i>context menu appears</i> . Select New , the Dielectric dialog box appears . By default the constant refractive index (Const Ref. Idx) is selected. Type the following information |



Name: **n=1.5**

Constant refractive index (isotropic) (Re): **1.5**

Click Store to save this material, Material n=1.5 will be listed under the **Dielectric** folder

- b. In the directory under **OptiFDTD_Designer1**, under the **Profiles** folder, right click the **Channel** folder. *A context menu appears. Select **New**. The **Channel Profile** dialog box appears.*

- Type the following Profile name: waveguide
- Under 3D profile definition: Type the following information:

Layer name: **WG**

Width: **1.0**

Thickness: **1.0**

Offset: **0.0**

- In the Material list, select n=1.5
- Click Add.
- To save the channel profile, click Store.

***Waveguide** appears in the Channel folder in the directory,*

- 4 Return to **Initial Properties** Dialog box of **Waveguide Layout Designer**
Either minimize or close the Waveguide Profile Designer.

- 5 Type the following information in each corresponding area in **Initial Properties** Dialog box

Waveguide Properties:

Width (um): 1.0

Profile: **Waveguide**

(This profile will be used by default when drawing a waveguide in the layout window)

Wafer Dimension

Length (um): **7.0** (z-direction dimension)

Width (um): **3.0** (x-direction dimension)

3D Wafer Properties

Cladding Material: **Air**

Cladding Thickness: **2.0** (y-direction dimension)

Substrate Material: **Air**

Substrate Thickness: **1.0** (y-direction dimension)

- 6 Click OK in **Initial Properties** Dialog box. **OptiFDTD Designer-[OptiFDTD Designer1]** window appears.

Note:

- Your shortcut Toolbars may not all appear in the window. You can change it from the "View->Toolbars" menu option.
- Click "+" (zoom) toolbar button to enlarge the layout window

7 Draw a linear waveguide in the layout window

- From the **Draw** menu, select **Linear Waveguide**. Or select the **Linear Waveguide** shortcut toolbar.
- In the layout window, drag the linear waveguide from the start point to the end point. A *linear waveguide* appears in the layout window.
- (Change the mouse drawing tool by selecting the arrow shortcut icon on the toolbar)
- To adjust the position and the shape of the waveguide, in the layout window, double-click the Linear Waveguide. *The **Linear Waveguide Properties** dialog box appears.*
- Click the **Start** tab and type the following values:

- Horizontal offset (um): **0.0** (Start point for z-direction)
- Vertical offset (um): **0.0** (Start point for x-direction)
- Width (um): **1.0** (Waveguide x-direction width)
- Depth (um): **0.0** (Waveguide y direction bottom)
- Label: **Linear1**
- Channel Thickness Tapering: **Use Default (Channel: None)**
(Waveguide y-direction thickness setting)

- Click the **End** tab and type the following values:

Horizontal offset (um): **7.0**
Vertical offset (um): **0.0**

Note:

- You can also set a variable in the expression - click **Evaluate** to verify the final value of the expression.
- Horizontal means the z-direction.
- Vertical means the x-direction.
- Depth means the y-direction.
- From the **Profile** list, select **Waveguide**.
- Click OK to finished the waveguide setting

Now, you have defined a simple straight waveguide. For more complex layout, Please refer to other tutorial lessons.

Note:

- **To add new materials and waveguide profiles select the Profiles and materials under the Edit menu of OptiFDTD Designer window to start the Profile Designer.**
- **To change the simulation domain dimension, select Wafer Properties under the Edit menu of OptiFDTD Designer window.**



Define Input Wave

The Input Wave signal is defined within the Input Plane. To insert the Input Plane and set the excitation wave, follow the steps below:

- | Step | Action |
|-------------|--|
| 1 | From the Draw menu, select Vertical Input Plane , or select Vertical Input Plane shortcut toolbar (The Vertical Input Plane is in the x-y plane for 3D.) |
| 2 | Click in the layout window at the position where you want to insert the Input Plane. <i>A red line that represents the input plane appears in the layout window.</i> |
| 3 | To set up the Input Plane properties, double-click the red line (Input Plane) in the layout window. <i>The Input Field Properties dialog box appears.</i> |
| 4 | Set the time domain Input Plane basic information. <ol style="list-style-type: none"> a. Select Gaussian Modulated Continuous Wave.
<i>The Gaussian Modulated CW tab appears.</i> b. Wavelength (um): 1.5 |

Note:

- Continuous Wave
 - Wavelength is a single wavelength that is used in simulations.
 - Gaussian Modulated Continuous Wave
 - Wavelength is the carrier wavelength (center wavelength) for the pulse simulations.
- 5** Click the **Gaussian Modulated CW** tab. To set the time domain input waveform. *The time domain pulse graphics appear.* Type the following values for the time domain input plane
- Time offset (sec.): **2.0e-14**
- Half width (sec.): **0.5e-14**

Note:

- Both the time domain wave and frequency domain wave for the Input Plane appear.
 - The Frequency domain information is obtained by FFT from the time domain series.
 - Right Click on the graph and select the **Zoom In** tool to enlarge the selected graph region. You can observe the bandwidth in this way.
 - Adjust half width can adjust the bandwidth
- 6** To set up the general information (transverse field distribution) for the Input Plane, click the **General** tab
- | | |
|-------------------------|------------------------------|
| Input Field Transverse: | Modal |
| Z Position (um): | 1.5 |
| Plane Geometry: | Positive direction |
| Label: | InputPlane1 (default) |

Note: Positive Direction means that the Input Plane is excited to the positive z-direction. TF/SF technique is used for the excitation algorithm, which makes sure the wave is excited and propagates only in one direction, and then behind the input wave the pure reflection wave can be detected.

- 7 To solve the 3D transverse mode, click the **3D Transverse** tab. Select one waveguide (it is selected by default in this sample) and click Find Mode. **ADI Method mode solver dialog box** appears. Follow the default setting to solve the mode:

General

Solver: **Real**
Waveguide: **Straight**

Mode:

Semi-vector TM, (y-polarization input wave)

Click **Calc Mode** to start the mode solving. The modal field and the modal index will be shown in the **M3DTmp3** window. Clicking this window will save the mode solver setting and come back to input plane dialog box.

Note: Click Data in mode solver **M3DTmp3** window to save (export) the results.

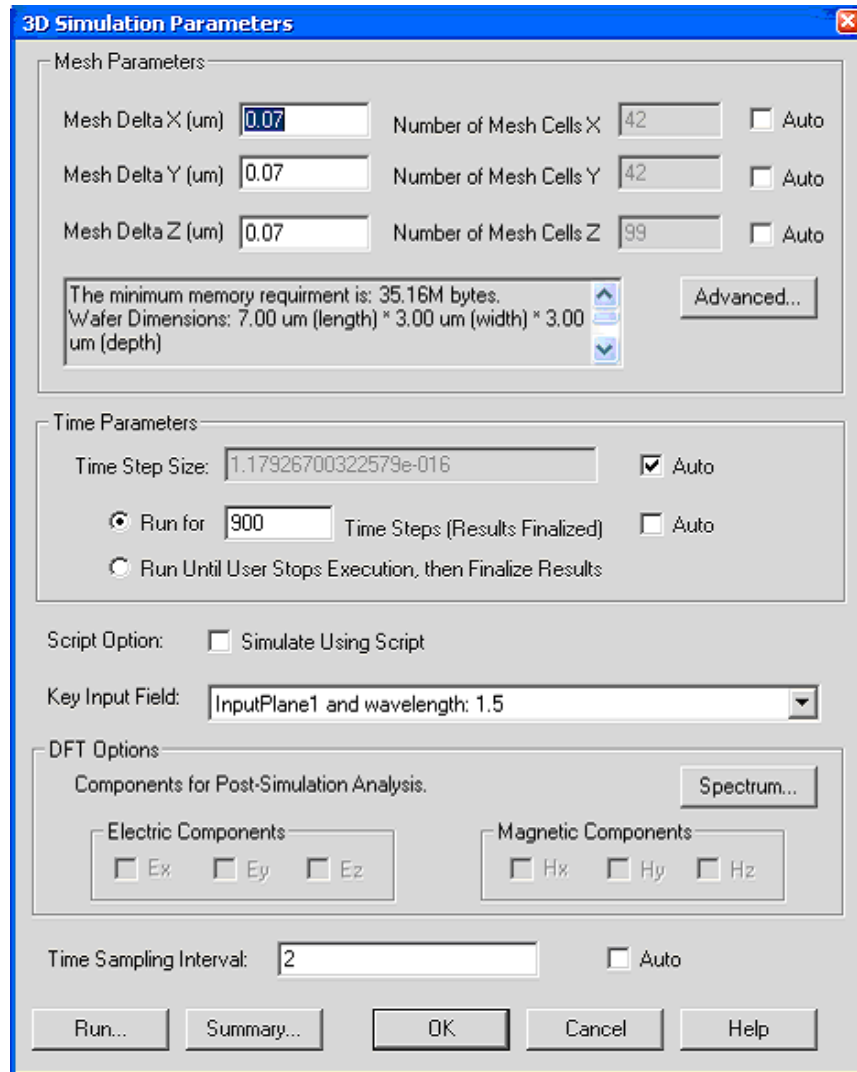
- 8 To complete the Input Plane setup, click **OK**.

Define Simulation Parameters

Step Action

- 1 From the **Simulation** menu, select **Simulate 3D Using 64-bit Simulator**. The **3D Simulation Parameters** dialog box appears (see [Figure 1](#)).3D simulation parameters dialog box

Figure 1 3D Simulation parameters dialog box



- 2 Type the following values for the mesh size:

Mesh Delta X (mm): **0.07**

Mesh Delta Y (mm): **0.07**

Mesh Delta Z (mm): **0.07**



Note: The total mesh number for each orientation will be calculated automatically, once focus is removed from the specific edit region.

- 3** To set up the boundary condition parameters, click **Advanced**. *The **Boundary Conditions** dialog box appears.* Type the following values for the boundary condition:

Anisotropic PML layer number:	12
Theoretical Reflection Coefficient:	1.0e-12
Real Anisotropic PML Tensor Parameter:	1.0
Power of grading Polynomial:	3.5

- 4** Run for 900 time steps
5 Time sampling interval: 5

Note:

- Time steps size

The default value ensures stability and accuracy of FDTD simulations

- Time step number

The default value ensures that the wave completes propagation through the whole layout

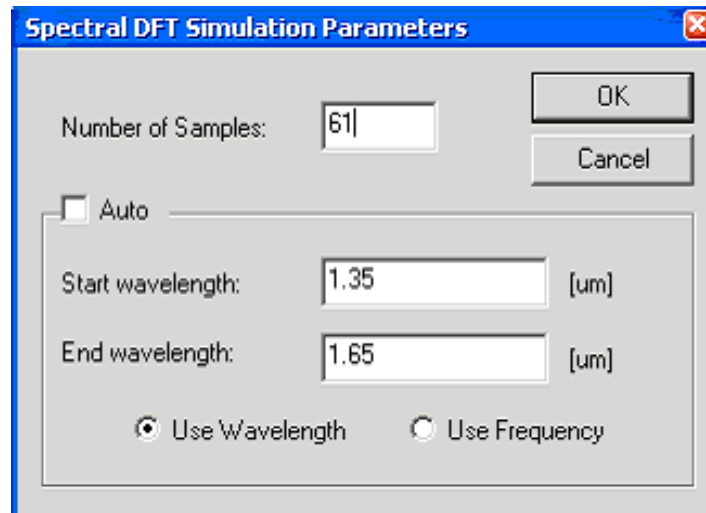
- Time sampling interval

This sampling rate applies to observation areas. It determines how many time domain response sample points are used for the spectrum calculation.

- 6** Click the **"Spectrum"** button to set the spectrum range (refer to [Figure 2](#))
 Set **"Number of Samples"** to 61,
 Uncheck the **"Auto"** checkbox,
 Check the **"Use Wavelength"** radio button
 Set Start wavelength as 1.35um
 Set end wavelength as 1.65um
 and press Ok button to accept changes



Figure 2 Spectrum DFT simulation parameters



- 7 Click Ok button to accept the specified simulation parameters

Observe the Refractive Index

- | Step | Action |
|------|--|
| 1 | Click on “ 3D_Ref_Idx-Re(y) ” tab on the bottom of the layout frame or select “ Refractive Index ” in the View Menu. View of the refractive index distribution slice appears. |
| 2 | Change the slice orientation and move the slice position to observe the index distribution (refer to Figure 3 , and Figure 4) <ul style="list-style-type: none"> — Select Height Plot shortcut toolbar to observe the refractive index in height plot format. — Right click on OptiFDTD graph to display the available graph tools/menus |



Figure 3 Refractive index in x-z orientation at y=0.5

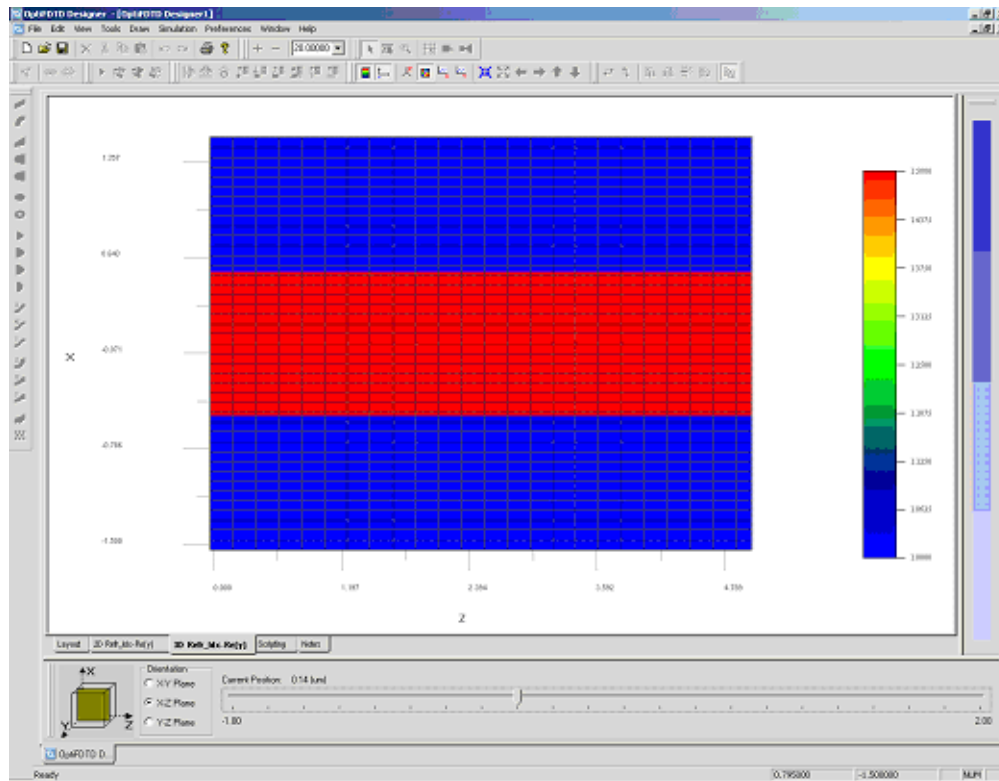
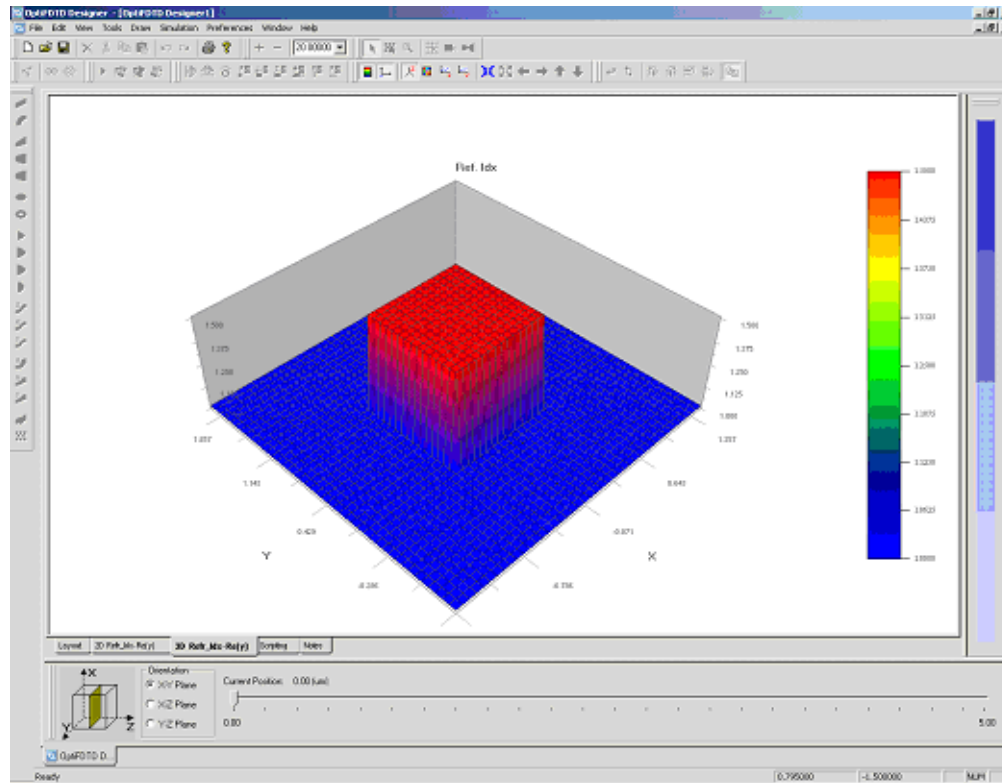


Figure 4 Refractive index in x-y orientation at z=0



Setup the Observation Objects (result data-detector)

For the 32-Bit FDTD simulation, observation objects will record all the time domain response so that spectrum analysis can be performed in analyzer. For 64-Bit FDTD simulation, Observation points will still record all the time domain response in each single point, but Observation area will perform the spectral analysis in simulator and save the spectrum DFT results to the analyzer file. For 64bit FDTD simulation, Observation Points or Observation Area must be present; otherwise simulations will not store any results for further analysis.

- **Observation Point**

Observes the time domain and frequency domain response. The transmission function can be obtained from the Observation Point analysis.

- **Observation Area**

It is used to compute power transmission ratio, and normalized power (power transmission /reflection) versus wavelength.



- | Step | Action |
|-------------|--|
| 1 | From the Draw menu, select Observation Point. (or select Observation Point shortcut from the toolbar) |
| 2 | Place the Observation Point in the desired position in the layout. |
| 3 | Double-click the observation point. <i>The “Observation Properties – Point” dialog box appears.</i> Type the following values in the dialog box |

General

Center Horizontal Offset:	5.2
Center Vertical Offset:	0.0
Center depth:	0.5
Label:	ObservationPoint1

Data Components

Ex, Ey

- | | |
|---|---|
| 4 | Click OK to close the dialog box |
| 5 | Repeat step 1-4 to design another Observation point with the following properties |

General

Center Horizontal Offset:	0.7
Center Vertical Offset:	0.0
Center depth:	0.5
Label:	ObservationPoint2

Data Components

Ex, Ey

Note:

- The Observation points are placed at the position where the peak value is expected. This will make sure that the response in observation point can be compared with the input wave peak value.
 - Observation point 1 will detect the transmitted wave while Observation Point 2 will detect the reflected wave.
- | | |
|---|---|
| 6 | From the Draw menu, select Observation XY Area (or select Observation XY Area shortcut from the toolbar) |
| 7 | Place the observation XY area in the desired position in the layout. |
| 8 | Double-click the observation area. <i>The “Observation Properties – XY area” dialog box appears.</i> Type the following values in the dialog box |



General

Center Horizontal Offset:	5.5
Center Vertical Offset:	0.0
Center depth:	0.5
X Length:	3.0
Y length:	3.0
Label:	ObservationArea1

Data Components**Ey, Hx****Note:**

- The time domain response for selected data components will be recorded through the simulation.
- Ey and Hx together will determine the y-polarization z-propagation Poynting vector

- 9** Click **OK** to close the Observation area dialog box
- 10** Repeat step 6-9 to design an **Observation XZ Area** with the follow properties

General

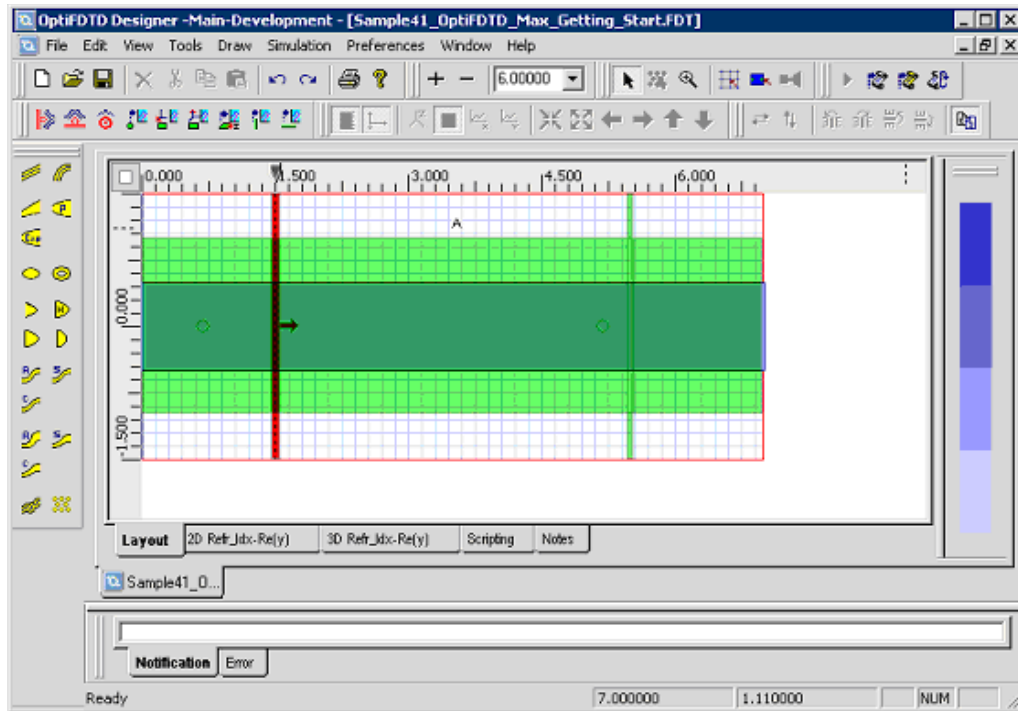
Center Horizontal Offset:	3.5
Center Vertical Offset:	0.0
Center depth:	0.5
X Length:	2.0
Z length:	7.0
Label:	ObservationArea2

Data Components

Ey

Click **Save** under **File** menu to save the designed project. Now your layout should look like the one on [Figure 5](#)

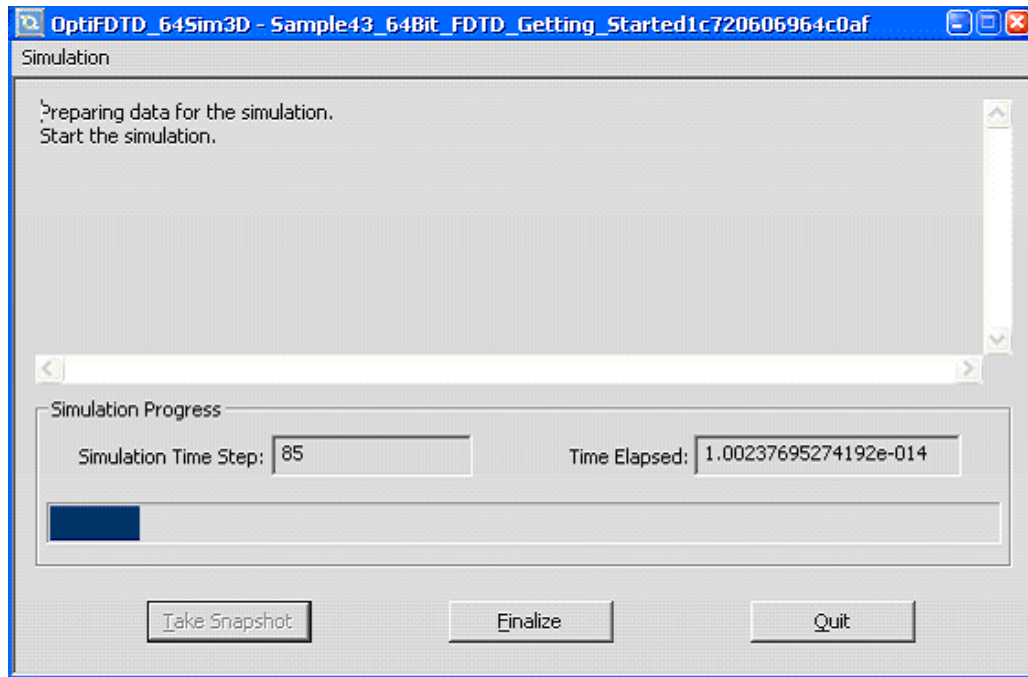
Figure 5 Layout



Perform the 64Bit-FDTD FDTD Simulation

- | Step | Action |
|------|--|
| 1 | From the Simulation menu, select the “ Simulate 3D using 64-Bit Simulator... ” option. <i>The 3D Simulation Parameters dialog box appears.</i> |
| 2 | Click Run to start the simulation. The progress window appears (see Figure 6). It displays status of the simulations. |

Figure 6 FDTD simulation progress window



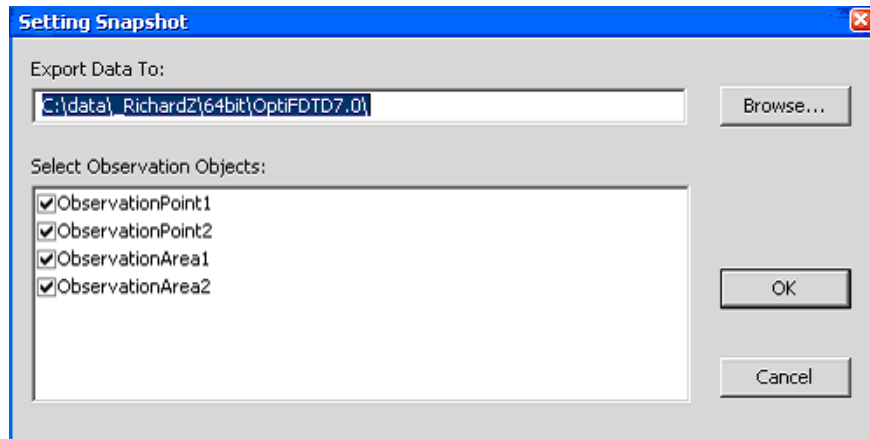
3 Visualization of intermediate simulation results.

First, configure the snapshot settings. Select “**Simulation ->Take Snapshot**” menu option. The “**Set Snapshot**” dialog box appears (Figure 7)

- Click **Browse** button to select the location of the output file
- Check the observation areas or observation points. The time domain response in the selected observation objects for the current time-step will be save to the file
- Click **OK** to close this dialog box

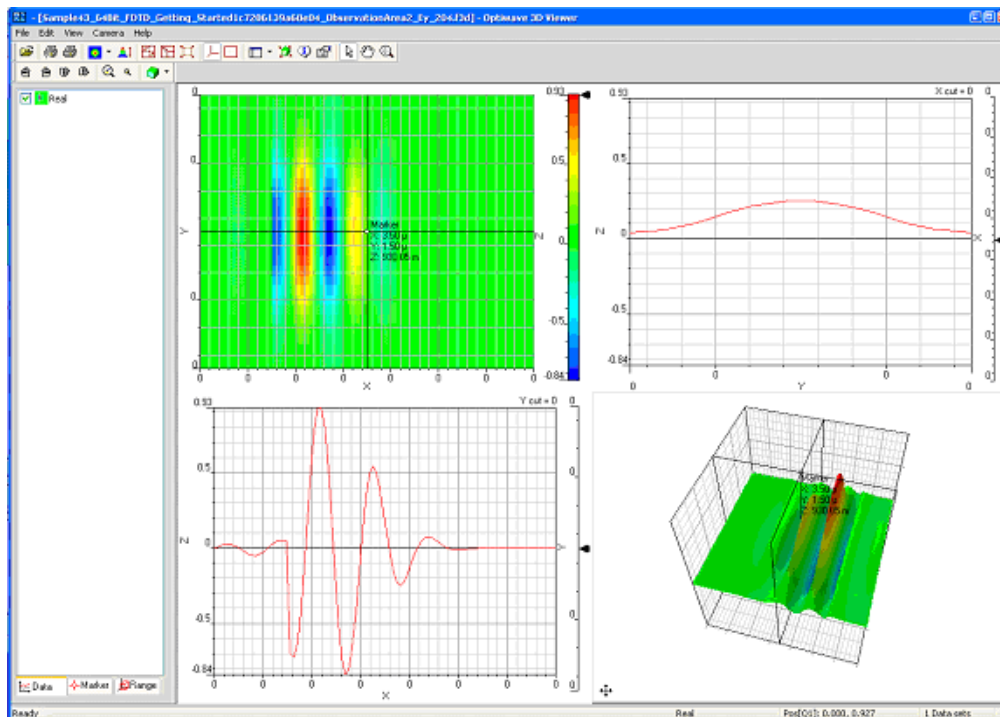


Figure 7 Setting Snapshot dialog box



- 4 Click the **“Take Snapshot”** button in the simulation progress dialog box to save the time domain response in the current displayed time step
- 5 Go to the folder where the snapshot is saved and with 2D or 3D Viewer observe the time domain response for a certain time step (refer to [Figure 8](#))

Figure 8 The time domain snapshot observed in 3D Viewer from observation area 2



When Simulation is finished, you will be asked if you want to open the analyzer to view the results. Click **yes** to start the analyzer

Post-Simulation Data Analysis

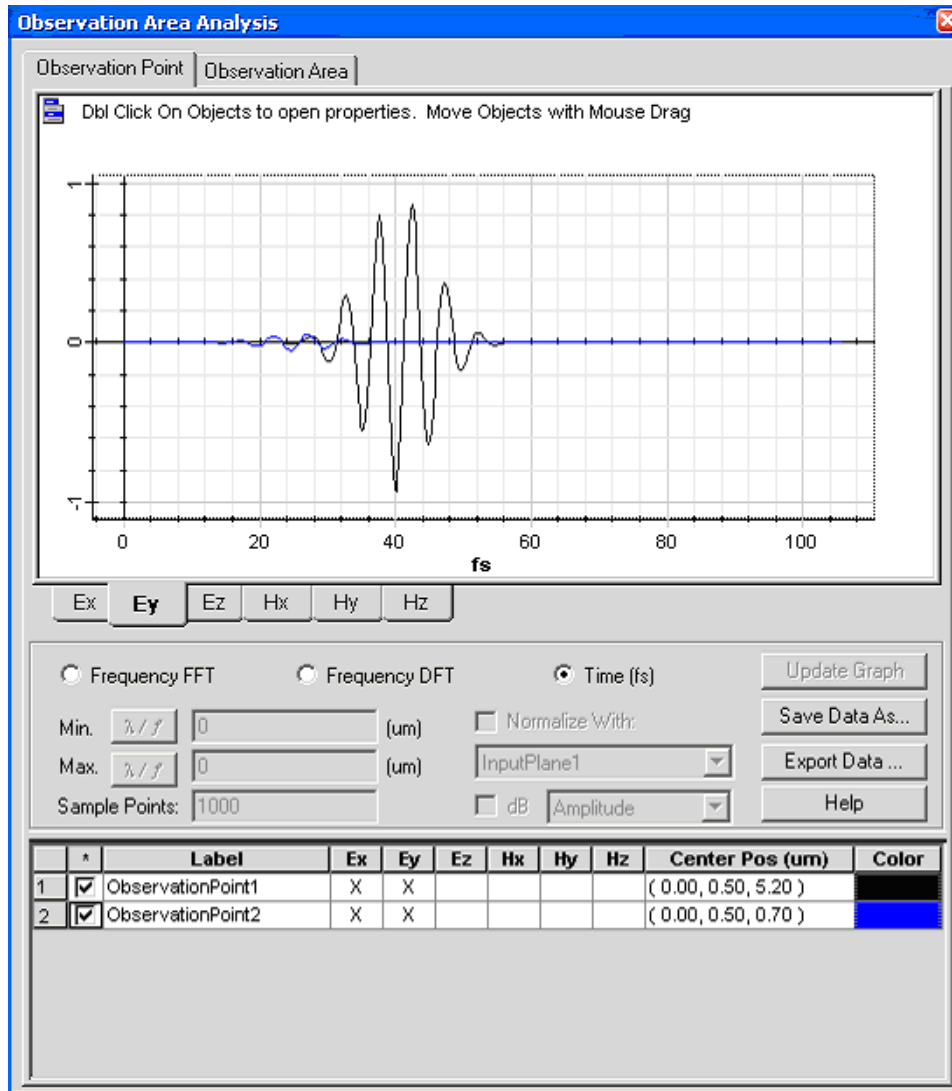
Our Analyzer provides a number of tools allowing for evaluation simulation results.

Observation Point

- | Step | Action |
|------|--|
| 1 | Select "Observation Area Analysis" under the "Tools" menu in the Analyzer. Observation Point dialog box appears |
| 2 | To observe the time domain response in the observation point, check the observation point object, select the field components button, and select Time radio button. (See Figure 9) |



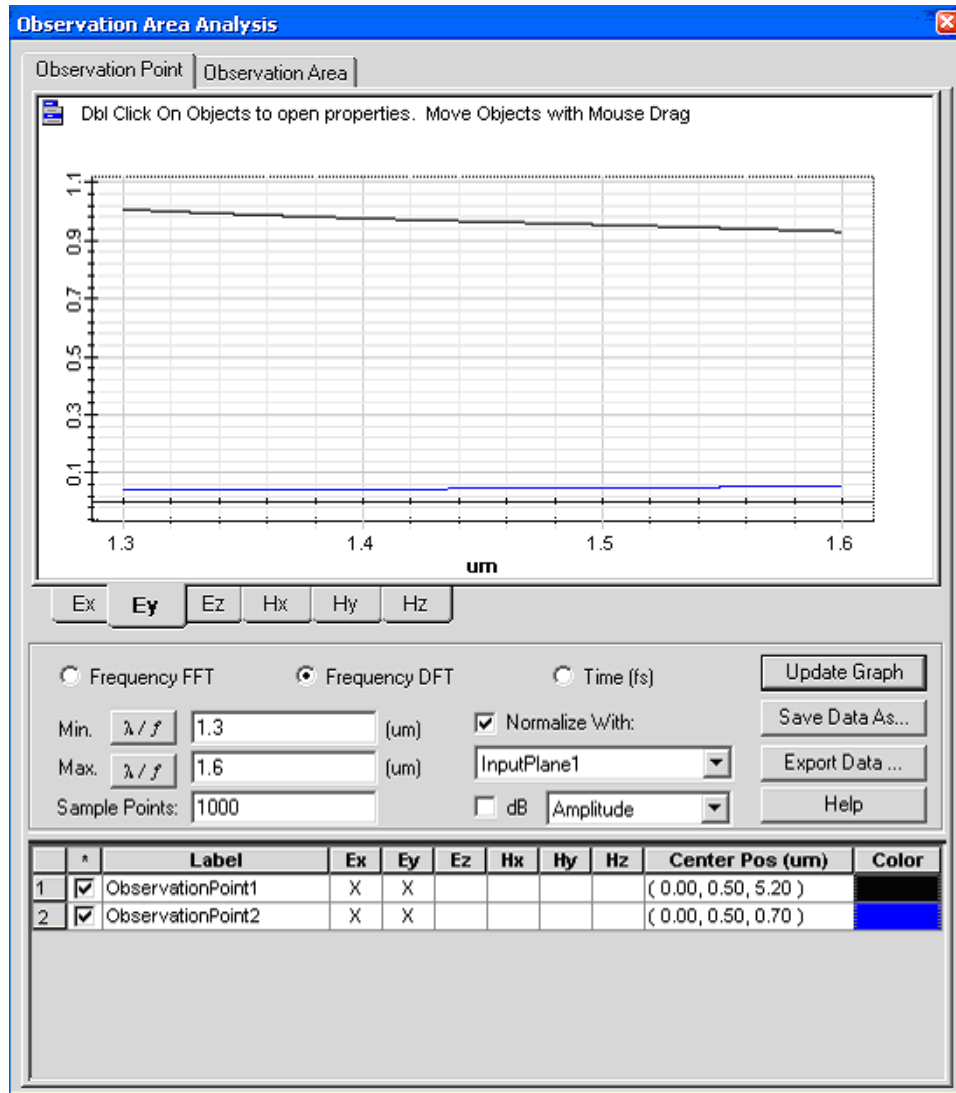
Figure 9 Time domain response in observation point



- 3 To get the transmission /reflection function response in an observation point, select **Frequency FDT** radio button. And type the following values (See [Figure 10](#))

Minimum wavelength: **1.3**
 Maximum wavelength: **1.6**
 Sample point: **1000**
 Normalize with: **InputPlane1**
 Click **Update Graph** button

Figure 10 Transmission/Reflection function based on Observation point



Field pattern in Observation Area

Step	Action
------	--------

- | | |
|---|--|
| 1 | Select Observation Area in Observation Area Analysis dialog box. |
| 2 | Select "ObservationArea2" in the observation area check list |
| 3 | Select wavelength 1.5 from the <i>l/f</i> list box |

Note:

- Click *l/f* button to alternate the unit between wavelength and frequency
 - The wavelength or frequency value is pre-set in the spectrum setting dialog box (refer to [Figure 2](#))
- | | |
|---|---|
| 4 | Click Update Graph (see Figure 11) |
| 5 | Repeat step 2 to step 4 for ObservationArea1 (See Figure 12) |



Figure 11 Field pattern in Observation area 2

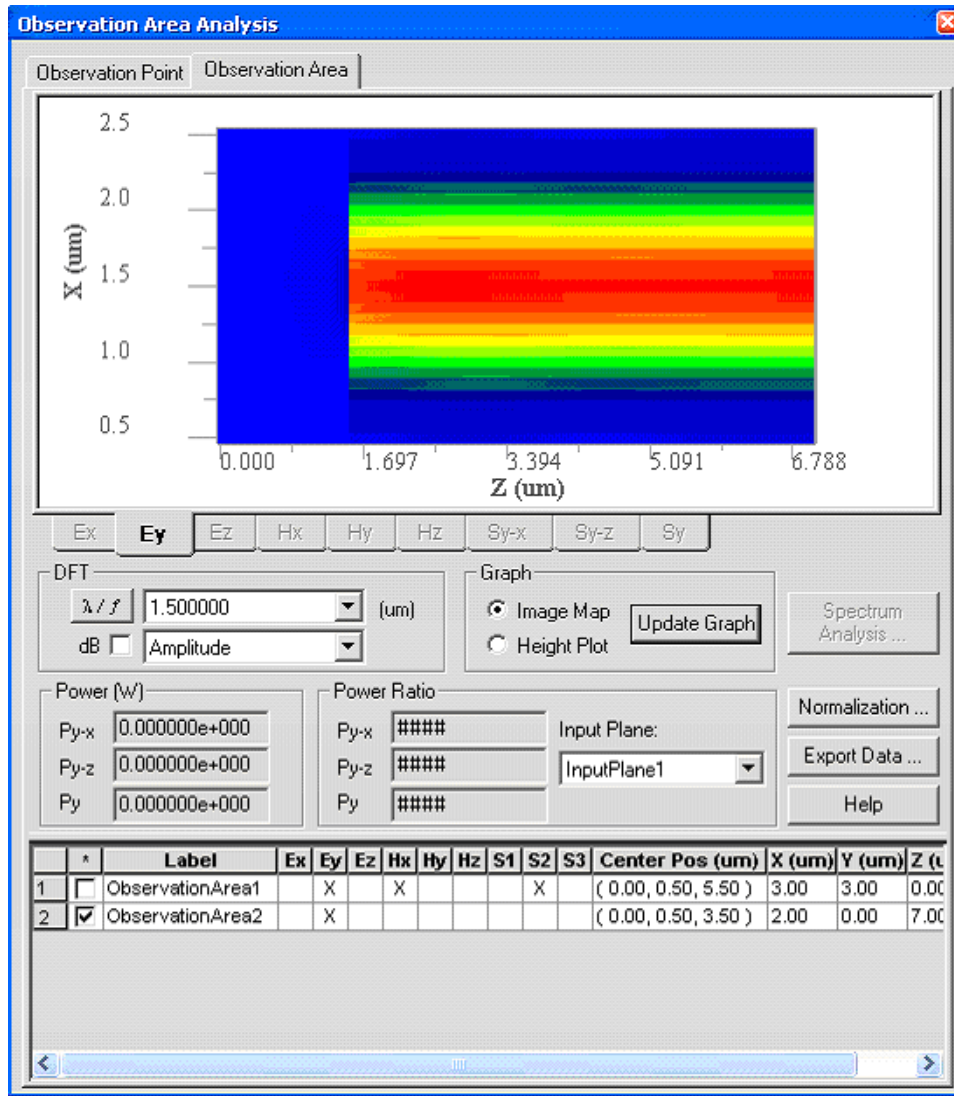
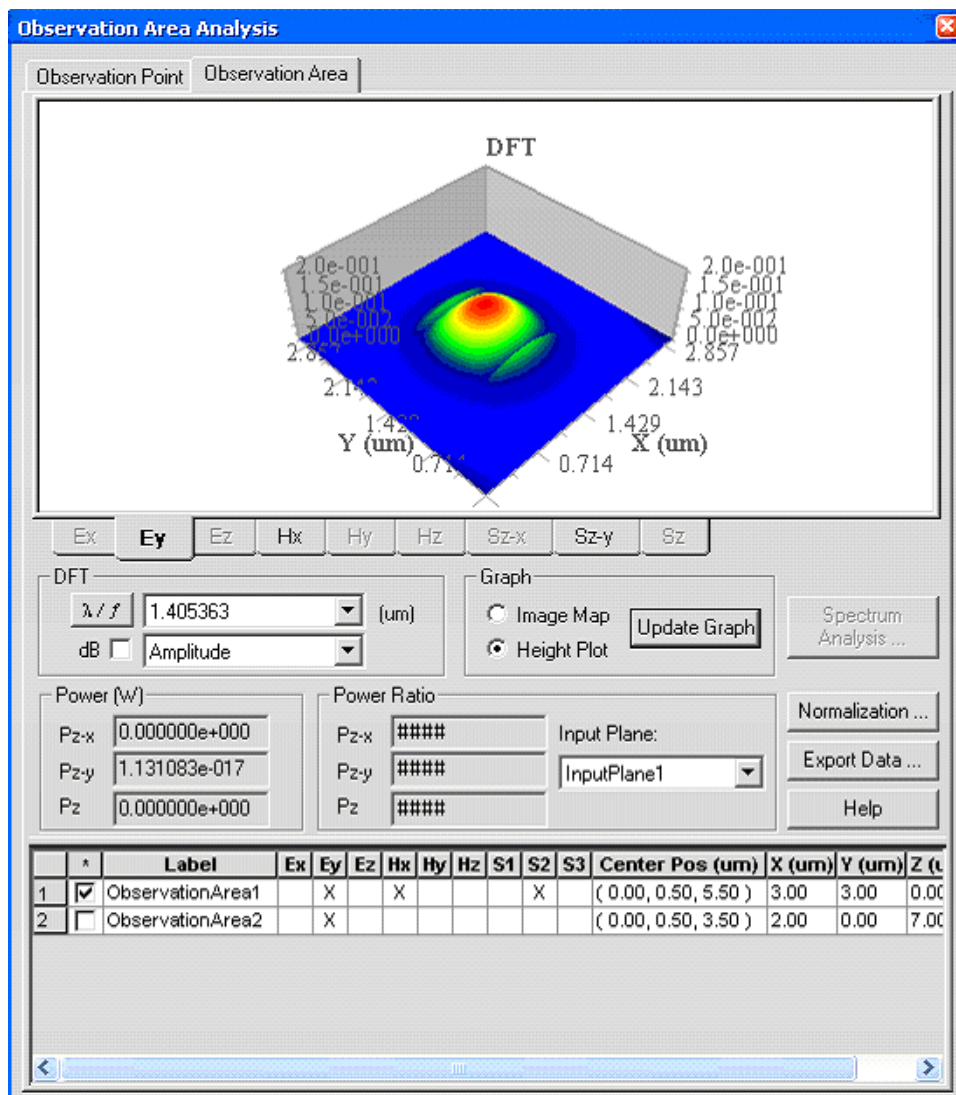


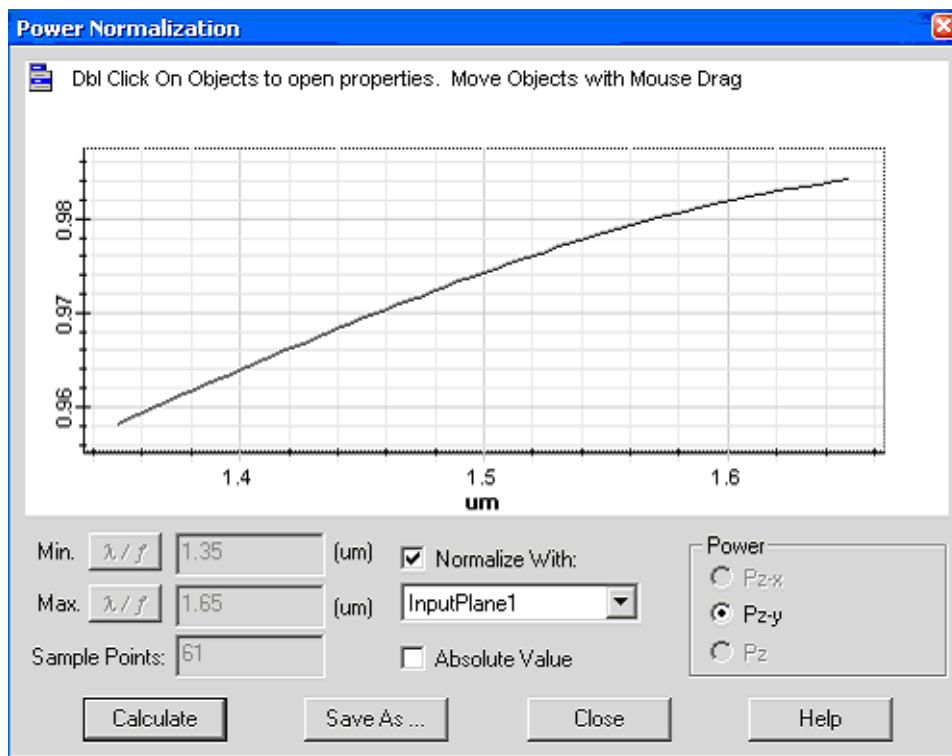
Figure 12 Field pattern in Observation area 1



Power transmission/reflection function

- | Step | Action |
|------|--|
| 1 | Select Observation Area in Observation Area Analysis dialog box. |
| 2 | Select "ObservationArea2" in the observation area check list |
| 3 | Select Power Spectrum button, Power Spectrum dialog box appears |
| 4 | Check "normalize with" checkbox and click Calculate button, Power Transmission spectrum appears, (refer to Figure 13) |

Figure 13 Power transmission spectrum



Note:

- In order to perform power calculations, the necessary field components have to be selected for different polarization power.
- When an observation area is behind the input wave, it can detect the reflection power spectrum

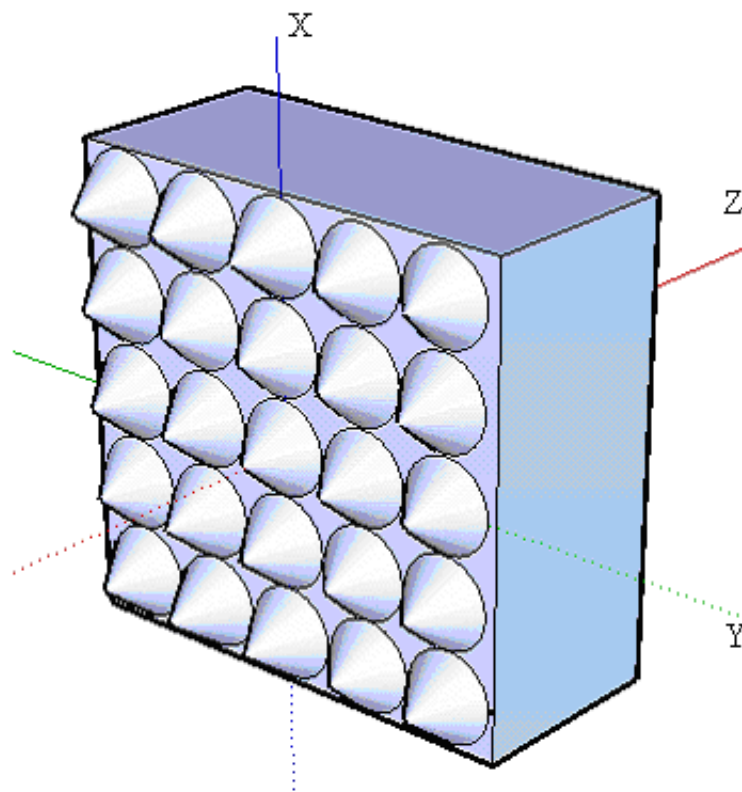
Lesson 19 - Heating absorption simulation using 64bit processor

Metallic and lossy materials in solar cells or other semiconductor devices in general absorb part of the light wave energy, converting it to heat. This lesson demonstrates the heating absorption simulation in OptiFDTD

The layout we will simulate is shown in [Figure 1](#), the corresponding project file (Sample44_3D_Heating_Absorption_64bit.fdt) can be found under the **Sample** folder of your software installation directory

Sample44_3D_Heating_Absorption_64Bit.fdt.

Figure 1 simulated layout



The layout represents a square of periodic cones with height (z-direction length) of $1\mu\text{m}$ deposited on the flat substrate. The diameter of the cone's bottom is $1\mu\text{m}$, the

cone and substrate have the same refractive index which is $n=2.4-j0.056$. The cone lattice extends to infinity in x and y-direction, the input wave is the plane wave with zero tilting angle. In this case a 5X5 cone layout is taken for simulation with the x- and y-edge set as periodic boundary condition. The following are the detailed steps for the layout creation, simulation, and post-simulation analysis.

Layout creation steps

- | Step | Action |
|-------------|--|
| 1 | <p>Open OptiFDTD Waveguide layout Designer</p> <p>From the Start menu, select Programs ->Optiwave Software -> OptiFDTD -> Waveguide Layout Designer. OptiFDTD_Designer window opens.</p> |
| 2 | <p>Create a new project.</p> <p>From the OptiFDTD_Designer File menu, select New. The Initial Properties dialog box appears.</p> |
| 3 | <p>Define the material(s) and waveguide profile(s) that will be used in the project.</p> <p>Click the Profiles and Materials button in the Initial Properties dialog.</p> <p>The Profile Designer OptiFDTD opens.</p> |

Note: At any time, you can open the **Profile Designer** from the “**Edit->Profiles and Materials...**” menu of the **Layout Designer** or from the **Start** menu. So you can make appropriate modifications to the defined materials and profiles whenever it is needed.

- a. In the three listing of profiles and materials of Profile Designer under **OptiFDTD_Designer1** in the **Materials** folder, right-click the **Dielectric** folder. A context menu appears. Select **New**, the **Dielectric** dialog box appears. By default the constant refractive index (**Const Ref. Idx**) is selected. Type the following information:
 - Name: **n=2.4-j0.056**
 - Constant refractive index (isotropic):
(Re): 2.4, (Im): 0.056
 - Click **Store** to save this material, Material **n=2.4-j0.056** will be listed under the
 - **Dielectric** folder

- b. In the directory under **OptiFDTD_Designer1**, under the **Profiles** folder, right click the **Channel** folder. A context menu appears. Select **New**. The **Channel Profile** dialog box appears. Type the following information:
 - Profile name: **ChannelPro1**



- Under 3D profile definition: Type the following information:

Layer name: **Layer1**

Width: **5**

Thickness: **5**

Offset: **0.0**

- In the Material list, select **n=2.4-j0.056**
- Click Add.
- To save the channel profile, click **Store**.

ChannelPro1 appears in the **Channel** folder,

- c. In the directory under **OptiFDTD_Designer1**, under the **Profiles** folder, right click the **Fiber** folder. A context menu appears. Select **New**. The **Fiber Profile** dialog box appears. Type the following:

- Profile name: **FiberPro1**

- Under 3D profile definition: Type the following information:

Layer name: **Layer1**

Rx (x-direction radius): **0.5**

Ry (y-direction radius): **0.5**

- In the Material list, select **n=2.4-j0.056**
 - Click **Add**.
- To save the channel profile, click **Store**.

FiberPro1 appears in the **Channel** folder,

- 4 Return to **Initial Properties** dialog box of **Waveguide Layout Designer**
Either minimize or close the Waveguide Profile Designer.

- 5 Type the following information in each corresponding area in **Initial Properties** dialog box

- **Waveguide Properties:**

Width (um): **1.0**

Profile: **FiberPro1**

(This profile will be used by default when drawing a waveguide in the layout window)

- **Wafer Dimension**

Length (um): **5.0** (z-direction dimension)

Width (um): **5.0** (x-direction dimension)



- **3D Wafer Properties**
 - Cladding Material: **Air**
 - Cladding Thickness: **5** (y-direction dimension)
 - Substrate Material: **Air**
 - Substrate Thickness: **0** (y-direction dimension)

- 6 Click **OK** in **Initial Properties** dialog box. **OptiFDTD Designer-[OptiFDTDigner1]** window appears.

Note:

- If not all Toolbars appear in the Layout Designer window, you can change it from the “**View->Toolbars**” menu option.
- Click “**+**” (zoom) toolbar button to enlarge the layout window.
- Open “**Wafer Properties**” from the **Edit** menu to modify simulation domain properties.
- Select “**Profiles and Materials**” from the **Edit** menu to open the **Profile Designer** where you can add and modify materials and profiles.

- 7 Draw a linear waveguide (the substrate in [Figure 1](#)) in the layout window

- From the **Draw** menu, select **Linear Waveguide**. Or select the **Linear Waveguide** shortcut toolbar.
- In the layout window, drag the linear waveguide from the start point to the end point. A *linear waveguide* appears in the layout window.(Change the mouse drawing tool by selecting the arrow shortcut icon on the toolbar)
- To adjust the position and the shape of the waveguide, in the layout window, double-click the Linear Waveguide. The **Linear Waveguide Properties** dialog box appears.
- From the **Profile** list, select **ChannelPro1**.
- Click the **Start** tab and type the following values:
 - Horizontal offset (μm): **3.0** (Start point for z-direction)
 - Vertical offset (μm): **0.0** (Start point for x-direction)
- Click the **End** tab and type the following values:
 - Horizontal offset (μm): **5.0**
 - Vertical offset (μm): **0.0**
- Channel Thickness Tapering:
 - Use Default (Channel: None): Uncheck
 - Taper: **Linear**
 - Start: **5**
 - End: **5**
- Width (μm): **5.0** (Waveguide x-direction width)



- Depth (μm): **0.0** (Waveguide y direction bottom)
- Label: **Linear1**
- Click **OK** to finished the waveguide setting

Note:

- You can parameterize the waveguide by entering a user-defined variable (parameter) in the **Expression** field. The expression fields are marked with "**fx**". For example you can enter StartPosZ (or an expression like $2 * \text{StartPosZ}$), in the **Expression** field of **Horizontal** position definition. After that press the **Evaluate** button, to see the resulting **Position** value. If the specified parameter has not been defined, then the software will prompt you to define it.
- Horizontal means the z-direction.
- Vertical means the x-direction.
- Depth means the y-direction.

8 Draw Cones

- From the **Draw** menu, select **PBG Crystal Structure**.
- With the mouse cursor click once on the layout window, *The **PBG Crystal Structure*** appears in the layout window. Click **Select** tool button (the arrow) on the shortcut toolbar to release the PBG selection.
- Double-click on the PBG structure (a rectangular shape) on the layout. *The **Crystal Lattice Properties*** dialog box appears.
- In the **Crystal Lattice Properties** dialog box, set the following lattice reference position parameters:

Origin

Horizontal Offset:	2.0
Vertical Offset:	-2.0
Depth:	0.5

- In the **Crystal Lattice Properties** dialog box, set the following Lattice vector parameters:

Lattice Properties:

Type:	3D rectangular
Fill:	Block

Lattice Dimension:

Scale:	1.0
#A:	5

#B: 5
#C: 1

- In the **Crystal Lattice Properties** dialog box, set the **Atom Waveguide** (Cone) properties:

In **Atom Waveguide in Unit Cell, Add New**, select **Linear Taper Waveguide** from the drop-down menu and click **New**. The **Linear Taper Waveguide Properties** dialog box appears. In **Linear Taper Waveguide Properties** dialog box set following value:

Profile: FiberPro1

Start
Horizontal Offset: 0
Vertical Offset: 0

End
Horizontal Offset: 1
Vertical Offset: 0

Fiber Diameter Tapering
User Default (checked)

Width
Start: 0
End: 1.0
Depth: 0

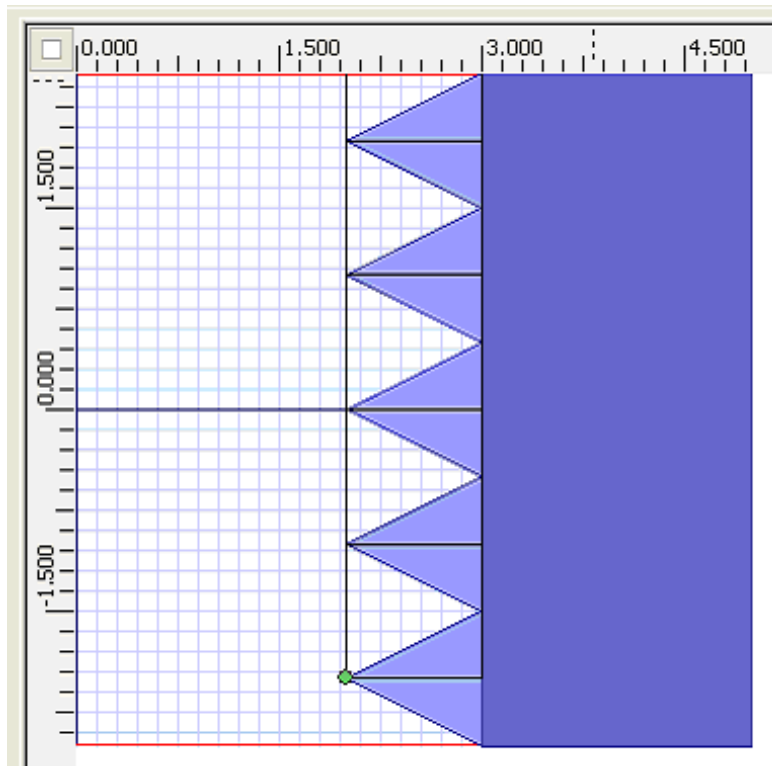
Click **OK** to close the Linear Taper Waveguide setting.

- In the **Crystal Lattice Properties** dialog box, click **OK** to close the Crystal Lattice setting.

The layout creation is finished; the layout window should like the [Figure 2](#)



Figure 2 Layout in OptiFDTD



Define Input Wave

The Input Wave signal is defined within the Input Plane. To insert the Input Plane and set the excitation wave, follow the steps below:

- | Step | Action |
|------|--|
| 1 | From the Draw menu, select Vertical Input Plane , or select Vertical Input Plane shortcut toolbar (The Vertical Input Plane is in the x-y plane for 3D.) |
| 2 | Click in the layout window at the position where you want to insert the Input Plane. <i>A red line that represents the input plane appears in the layout window.</i> |
| 3 | To set up the Input Plane properties, double-click the red line (Input Plane) in the layout window. <i>The Input Field Properties dialog box appears.</i> |
| 4 | Set the time domain Input Plane basic information. <ul style="list-style-type: none"> • Select Gaussian Modulated Continuous Wave.
The Gaussian Modulated CW tab appears. • Wavelength (um): 1.55 |



Note:

- Continuous Wave
The specified wavelength is a single wavelength that is used in simulations.
- Gaussian Modulated Continuous Wave
The specified wavelength is the carrier wavelength (center wavelength) for the pulse simulations.

5 Click the **Gaussian Modulated CW** tab. To set the time domain input waveform. The time domain pulse graphics appear. Type the following values for the time domain input plane:

Time offset (sec.):	1.5e-14
Half width (sec.):	0.4e-14

Note:

- Both the time domain wave and frequency domain wave for the Input Plane appear.
- The Frequency domain information is obtained by FFT from the time domain series.
- Right Click on the graph and select the **Zoom In** tool to enlarge the selected graph region. You can observe the bandwidth in this way.
- Adjust half width can adjust the bandwidth

6 To set up the general information (transverse field distribution) for the Input Plane, click the **General** tab

- **Input Field Transverse:** Rectangular
- Click 3D transverse to set the rectangular wave properties as the following:

Center Position X:	0.0
Half width X	3.0
Center Position Y:	2.5
<i>Half width Y</i>	3.0
Tilting Angle:	0.0

Effective refractive Index:	Local
-----------------------------	--------------

Polarization:	Linear Y
---------------	-----------------

Amplitude:	1.0
------------	------------

7 Click **General** tab. Set **z-position** in the **Geometry and Wave Configure** region as 1.0

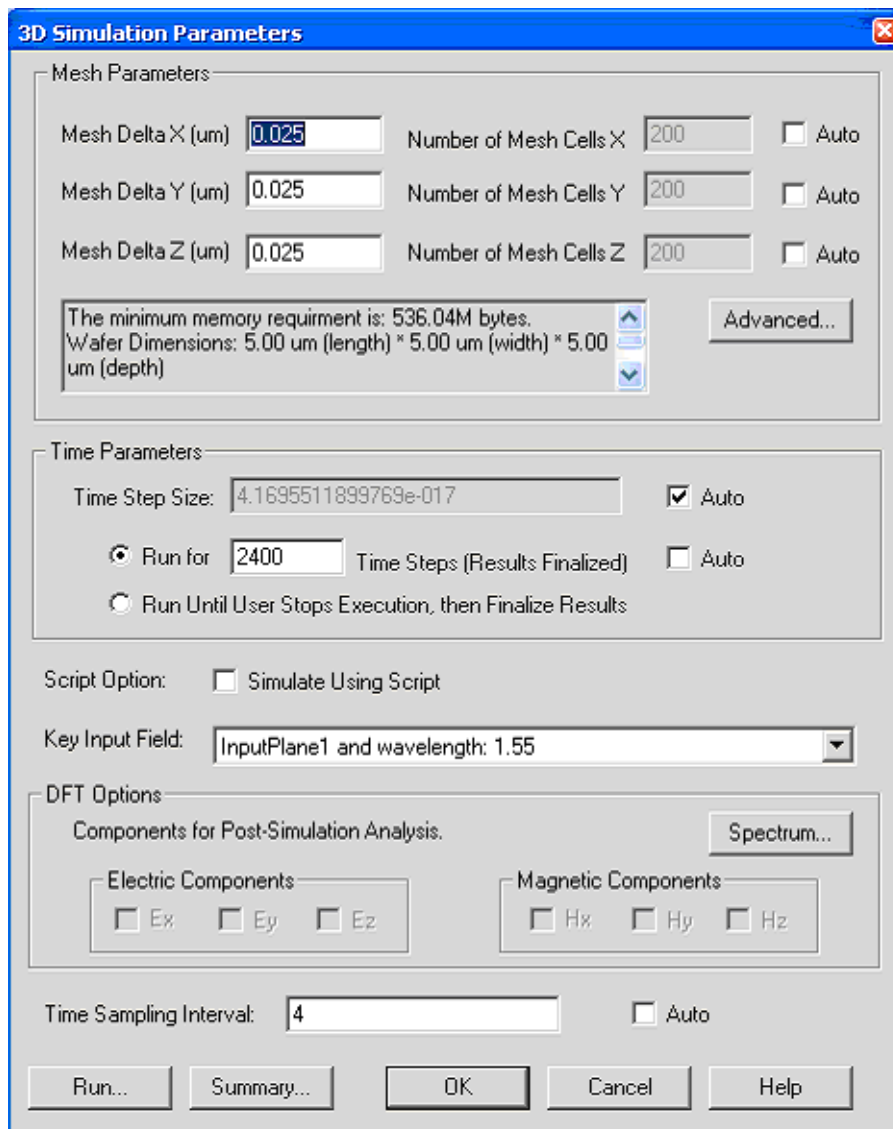


Define Simulation Parameters

Step Action

- 1 From the **Simulation** menu, select **Simulate 3D Using 64-bit Simulator**. The **3D Simulation Parameters** dialog box. 3D simulation parameters dialog box ([Figure 3](#))

Figure 3 3D Simulation parameters dialog box



- 2 Uncheck **Auto** in the mesh parameters region, type the following values for the mesh size:

Mesh Delta X (mm): **0.025**
Mesh Delta Y (mm): **0.025**
Mesh Delta Z (mm): **0.025**

- 3 To set up the boundary condition parameters, click **Advanced**. The **Boundary Conditions** dialog box appears (Figure 4). Type the following values for the boundary condition:

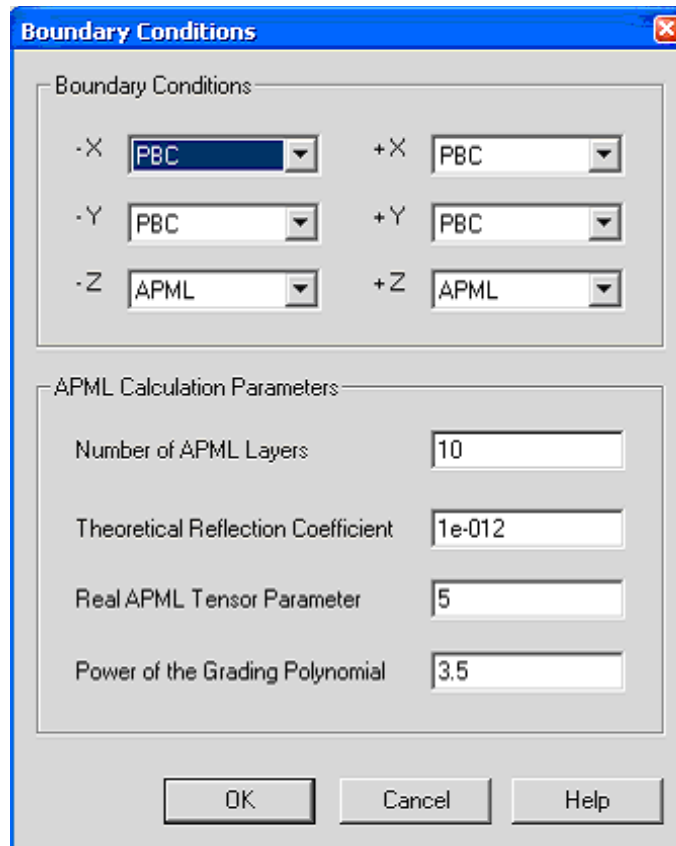
- Boundary Condition
 X: PBC
 Y: PBC
 Z: APML

- APML Calculation Parameters:

Anisotropic PML layer number: **10**
Theoretical Reflection Coefficient: **1.0e-12**
Real Anisotropic PML Tensor Parameter: **5**
Power of grading Polynomial: **3.5**



Figure 4 Boundary condition dialog box



- 4 Set the Time Steps to 2400.
- 5 Set the Time Sampling Interval at 4.
Note: This is the time domain data sampling rate for spectrum analysis.
- 6 Click the **"Spectrum"** button to set the spectrum range (refer to [Figure 5](#))
 - Set **"Number of Samples"** to 81,
 - Uncheck the **"Auto"** checkbox,
 - Check the **"Use Wavelength"** radio button
 - Set Start wavelength as 1.35um
 - Set end wavelength as 1.75um
 - and press Ok button to accept changes

Observe the Refractive Index (Optional)

- | Step | Action |
|------|--|
| 1 | Click on “3D_Ref_Idx-Re(y)” tab on the bottom of the layout frame or select “Refractive Index” in the View menu. View of the refractive index cross-cut slice appears. |
| 2 | In the Orientation region which is in the left-bottom area of the window, change the slice orientation and move the slice position to observe the index distribution (refer to Figure 5 , and Figure 6) <ul style="list-style-type: none"> • Select Height Plot shortcut toolbar to observe the refractive index in height plot format. • Right click on OptiFDTD graph to display the available graph tools/menus. |

Figure 5 Refractive index distribution in xz plane at y=0.5

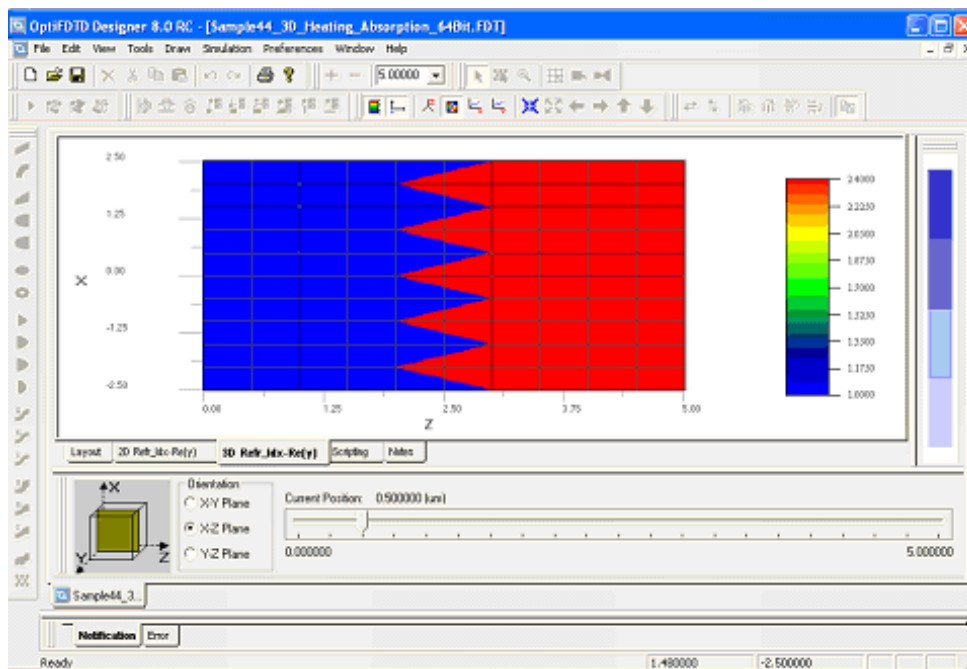
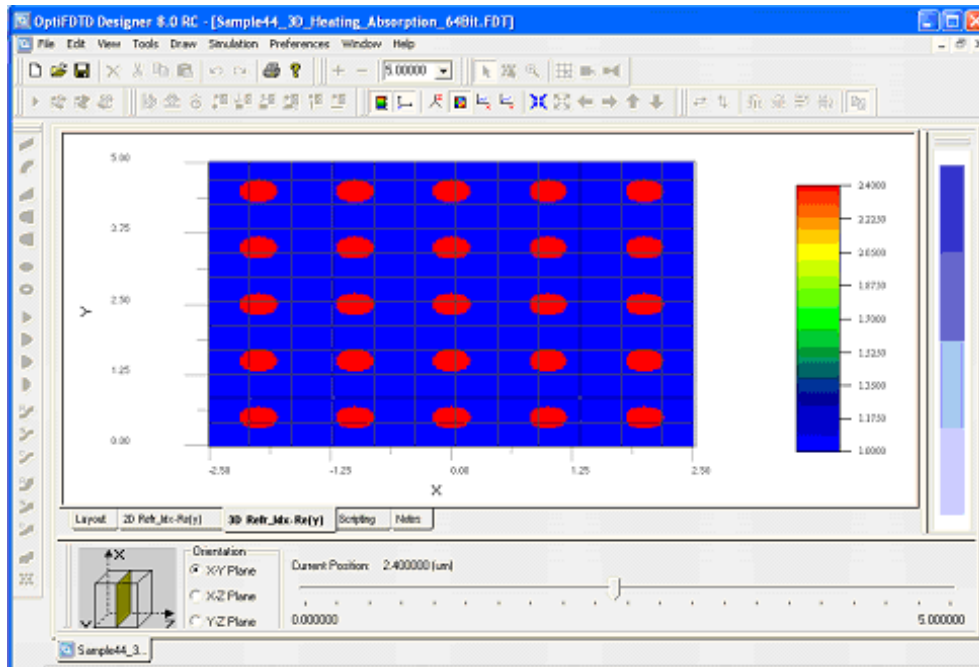


Figure 6 Refractive index distribution in xy plane at z=2.4



Setup the Observation Objects (result data detector)

For the 32-Bit FDTD simulation, observation objects will record the entire time domain response so that spectrum analysis can be performed in analyzer. For 64-Bit FDTD simulation, Observation Points will still record the time domain response in each single point, but Observation Area will perform the spectral analysis during the simulations and save the resulting DFT spectral data only. No time domain response data is stored for Observation Areas, due to its huge volume. For 64bit FDTD simulations, Observation Points or Observation Areas must be present, otherwise no result data will be stored during the simulations.

- **Observation Point**

Observes the time domain and frequency domain response. The transmission function can be obtained from the Observation Point analysis.

- **Observation Area**

It is used to compute power transmission ratio, normalized power (power transmission / reflection) versus wavelength and Heating Absorption.



- | Step | Action | | | | | | | | | | | | |
|---------------------------|---|---------------------------|------------|-------------------------|------------|---------------|------------|---------------|------------|-----------|------------|-----------------------|--|
| 1 | From the Draw menu, select Observation Point . (Or select Observation Point shortcut from the toolbar). | | | | | | | | | | | | |
| 2 | Place the Observation Point in the desired position in the layout. Double-click the observation point. The " Observation Properties – Point " dialog box appears. Type the following values in the dialog box <ul style="list-style-type: none"> • General <table border="0" style="margin-left: 20px;"> <tr> <td>Center Horizontal Offset:</td> <td style="text-align: right;">4</td> </tr> <tr> <td>Center Vertical Offset:</td> <td style="text-align: right;">0.0</td> </tr> <tr> <td>Center depth:</td> <td style="text-align: right;">2.5</td> </tr> </table> • Label: ObservationPoint1 • Data Components (3D) <table border="0" style="margin-left: 20px;"> <tr> <td style="text-align: center;">Ex, Ey</td> <td></td> </tr> </table> | Center Horizontal Offset: | 4 | Center Vertical Offset: | 0.0 | Center depth: | 2.5 | Ex, Ey | | | | | |
| Center Horizontal Offset: | 4 | | | | | | | | | | | | |
| Center Vertical Offset: | 0.0 | | | | | | | | | | | | |
| Center depth: | 2.5 | | | | | | | | | | | | |
| Ex, Ey | | | | | | | | | | | | | |
| 3 | Click OK to close the dialog box. | | | | | | | | | | | | |
| 4 | From the Draw menu, select Observation XY Area (or select Observation XY Area shortcut from the toolbar) | | | | | | | | | | | | |
| 5 | Place the Observation XY area in the desired position in the layout. | | | | | | | | | | | | |
| 6 | Double-click the Observation Area . The " Observation Properties – XY area " dialog box appears. Type the following values in the dialog box <ul style="list-style-type: none"> • General <table border="0" style="margin-left: 20px;"> <tr> <td>Center Horizontal Offset:</td> <td style="text-align: right;">2.5</td> </tr> <tr> <td>Center Vertical Offset:</td> <td style="text-align: right;">0.0</td> </tr> <tr> <td>Center depth:</td> <td style="text-align: right;">2.5</td> </tr> <tr> <td>X Length:</td> <td style="text-align: right;">5.0</td> </tr> <tr> <td>Y length:</td> <td style="text-align: right;">5.0</td> </tr> </table> • Label: ObservationArea1 • Data Components (3D) <table border="0" style="margin-left: 20px;"> <tr> <td style="text-align: center;">Ey, Hx, Ex, Hy</td> <td></td> </tr> </table> | Center Horizontal Offset: | 2.5 | Center Vertical Offset: | 0.0 | Center depth: | 2.5 | X Length: | 5.0 | Y length: | 5.0 | Ey, Hx, Ex, Hy | |
| Center Horizontal Offset: | 2.5 | | | | | | | | | | | | |
| Center Vertical Offset: | 0.0 | | | | | | | | | | | | |
| Center depth: | 2.5 | | | | | | | | | | | | |
| X Length: | 5.0 | | | | | | | | | | | | |
| Y length: | 5.0 | | | | | | | | | | | | |
| Ey, Hx, Ex, Hy | | | | | | | | | | | | | |
| 7 | Repeat step 4-6 to design an Observation XY Area with the following properties: <ul style="list-style-type: none"> • General <table border="0" style="margin-left: 20px;"> <tr> <td>Center Horizontal Offset:</td> <td style="text-align: right;">3.5</td> </tr> <tr> <td>Center Vertical Offset:</td> <td style="text-align: right;">0.0</td> </tr> <tr> <td>Center depth:</td> <td style="text-align: right;">2.5</td> </tr> <tr> <td>X Length:</td> <td style="text-align: right;">5.0</td> </tr> <tr> <td>Y length:</td> <td style="text-align: right;">5.0</td> </tr> </table> • Label: ObservationArea2 • Data Components <table border="0" style="margin-left: 20px;"> <tr> <td style="text-align: center;">Ey, Hx, Ex, Hy</td> <td></td> </tr> </table> | Center Horizontal Offset: | 3.5 | Center Vertical Offset: | 0.0 | Center depth: | 2.5 | X Length: | 5.0 | Y length: | 5.0 | Ey, Hx, Ex, Hy | |
| Center Horizontal Offset: | 3.5 | | | | | | | | | | | | |
| Center Vertical Offset: | 0.0 | | | | | | | | | | | | |
| Center depth: | 2.5 | | | | | | | | | | | | |
| X Length: | 5.0 | | | | | | | | | | | | |
| Y length: | 5.0 | | | | | | | | | | | | |
| Ey, Hx, Ex, Hy | | | | | | | | | | | | | |



8 Repeat step 4-6 to design an **Observation XZ Area** with the following properties:

- **General**
 - Center Horizontal Offset: **2.5**
 - Center Vertical Offset: **0.0**
 - Center depth: **0.5**
 - Z Length: **5.0**
 - X length: **5.0**
- Label: **ObservationArea3**
- **Data Components**
 - Ex, Ey, Ez**

Click **Save** under **File** menu to save the designed project.

Perform the 64Bit-FDTD FDTD Simulation

- | Step | Action |
|------|--|
| 1 | From the Simulation menu, select the “ Simulate 3D using 64-Bit Simulator... ” option. The 3D Simulation Parameters dialog box appears. |
| 2 | Click Run to start the simulation. The progress window appears, it displays the status of the simulations. |
| 3 | <p>Visualization of intermediate simulation results.</p> <ul style="list-style-type: none"> • When the Simulation Process window appears, from menu, select “Simulation ->Take Snapshot” menu option. The “Setting Snapshot” dialog box appears. • Click the Browse button to select the location of the output file. • Check the observation areas or observation points. The time domain response in the selected observation objects for the current time-step will be saved to the file • Click OK to close this dialog box. • Click the “Take Snapshot” button in the simulation progress dialog box to save the time domain response in the current displayed time step. Go to the folder where the snapshot is saved and with 2D or 3D Viewer observe the time domain response for a certain time step. |
| 4 | When the simulation is complete, click Yes to open the analyzer. |



Post-Simulation Data Analysis

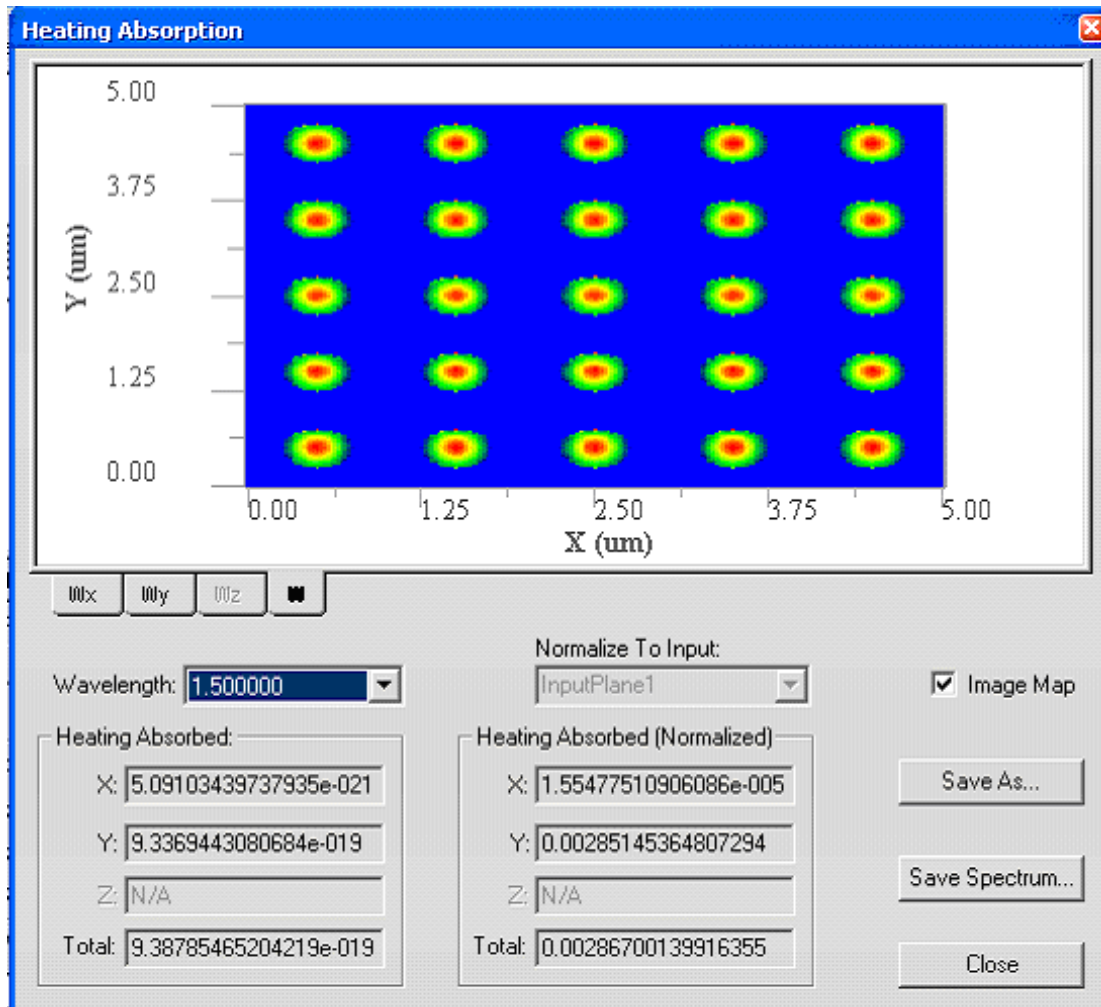
Our Analyzer provides a number of tools allowing for evaluation of different simulation results. The Heating absorption can be evaluated only in the Observation Area.

Step	Action
------	--------

- | | |
|---|---|
| 1 | Open results file by analyzer. |
| 2 | In the Tools menu, select Observation Area Analysis to open the dialog box. |
| 3 | Click on the Observation Area button to open “ ObservationArea2 ” in the observation area check list. Select wavelength 1.5 from the <i>l/f</i> list box |
| 4 | Click the Update Graph button, the steady state field pattern in the observation area will be updated for the user specified wavelength. |
| 5 | Click the Heating Absorption button, the “ Heating Absorption ” dialog appears <ul style="list-style-type: none">• From the wavelength list box, select the wavelength as 1.5μm• Click the Wx, Wy tab under the graph to observe the x-polarization, y-polarization heating absorption distribution.• Click W to observe the total heating absorption distribution (refer to Figure 7) |

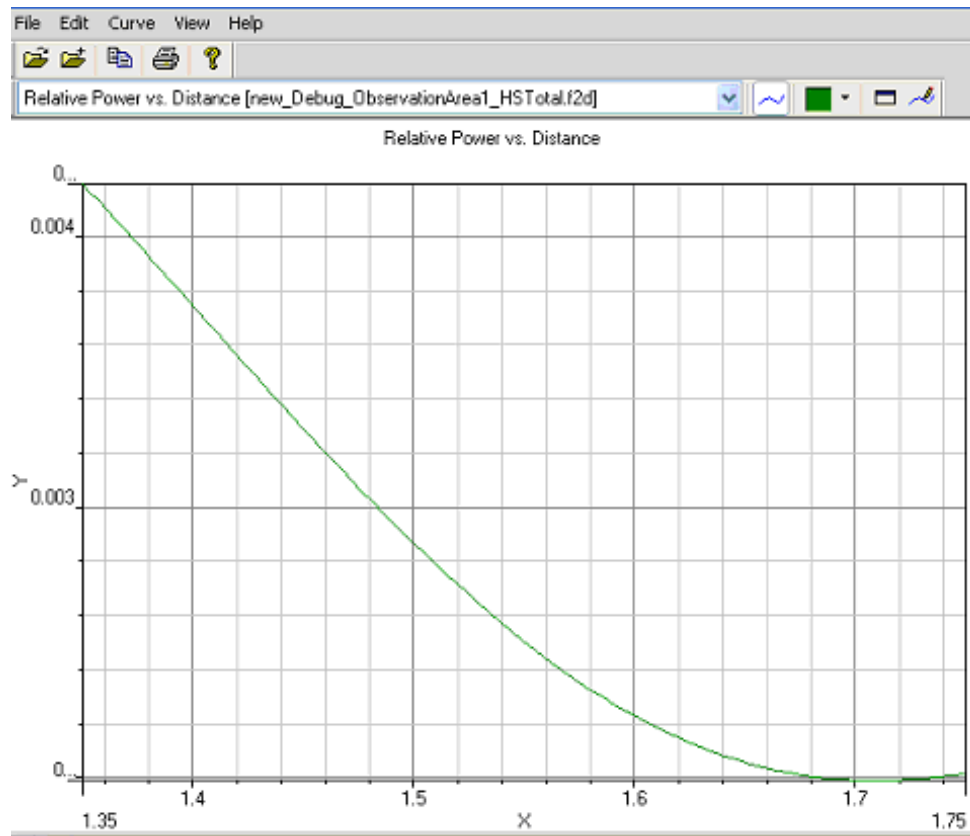


Figure 7 Heating absorption distribution



- The absorbed heating in this whole observation can be read in this dialog box. When this value normalizes to the input power for the specified wavelength, it will give the heating absorption ratio as shown the right column in the dialog box.
- Equations for the heating absorption calculation can be found in the technical background
- To get the normalized heating absorption spectrum for the selected heating absorption polarization, (i.e. Wx, Wy or W) Click the **Save Spectrum** button, and specify the file name for the output file.
- Use the 2D viewer to load the exported file (refer to [Figure 8](#))

Figure 8 Normalized total heating absorption spectrum.



- 6 Repeat steps 1-4 to observe the heating absorption for observation area 2 and 3.

Lesson 20 - 2D Total Field/Scattering Field(TF/SF) simulation and Radar Cross Section(RCS) Detection

2D Total Field/Scattering Field (TF/SF) is a special excitation type that excites arbitrary tilting plane wave in the enclosed rectangular surface. Inside the rectangular region, it generates the total field. Outside of this rectangular region, it is the pure scattering field. TF/SF simulation enable RADAR cross Section analysis. Complex grating layout analysis and other plane wave simulation will benefit from this TF/SF technique.

The following lesson show how TF/SF separate the total field and scattering field in free space and how RCS is detected for an infinite dielectric rod.

Note: The corresponding project file can also be found in the 32bit **Sample** file folder,

Sample49_2D_TE_TFSF_without_object.FDT

Sample50_2D_TE_TFSF_inf_Cylinder.FDT

Layout creation steps

- | Step | Action |
|------|---|
| 1 | Open OptiFDTD Waveguide layout Designer
From the Start menu, select Programs ->Optiwave Software -> OptiFDTD-> Waveguide Layout Designer . OptiFDTD_Designer window opens. |
| 2 | Create a new project.
From the OptiFDTD_Designer File menu, select New . The Initial Properties dialog box appears. |
| 3 | Define the material(s) and waveguide profile(s) that will be used in the project.
Click the Profiles and Materials button in the Initial Properties dialog.
The Profile Designer OptiFDTD opens. |

Note: At any time, you can open the **Profile Designer** from the “**Edit->Profiles and Materials...**” menu of the **Layout Designer** or from the **Start** menu. So you can make appropriate modifications to the defined materials and profiles whenever it is needed.

- a. In the tree listing of profiles and materials of Profile Designer under **OptiFDTD_Designer1** in the **Materials** folder, right-click the **Dielectric** folder. A context menu appears. Select **New**, the **Dielectric** dialog box appears. By default the constant refractive index (**Const Ref. Idx**) is selected. Type the following information:
 - Name: **er=2.0**
 - Constant refractive index (isotropic):
(Re): 1.414214, (Im): 0.0

- Click **Store** to save this material, Material **er=2.0** will be listed under the **Dielectric** folder.
 - b. In the directory under **OptiFDTD_Designer1**, under the **Profiles** folder, right click the **Channel** folder. A context menu appears. Select **New**. The **Channel Profile** dialog box appears. Type the following information:
 - Profile name: **ChannelPro1**
 - Under 2D profile definition, In the Material list, select **er=2.0**
 - To save the channel profile, click **Store**. **ChannelPro1** appears in the **Channel** folder.
- 4 Return to **Initial Properties** dialog box of **Waveguide Layout Designer**. Either minimize or close the Waveguide Profile Designer.
- 5 Type the following information in each corresponding area in **Initial Properties** dialog box
- **Waveguide Properties:**
 - Width (um): **1.0**
 - Profile: **ChannelPro1**
 - **Wafer Dimension**
 - Length (um): **2.0** (z-direction dimension)
 - Width (um): **2.0** (x-direction dimension)
 - **2D Wafer Properties**
 - Material: Air
- 6 Click **OK** in **Initial Properties** dialog box. **OptiFDTD Designer-[OptiFDTDigner1]** window appears.

Note:

- If not all Toolbars appear in the Layout Designer window, you can change it from the “**View->Toolbars**” menu option.
- Click “**+**” (zoom) toolbar button to enlarge the layout window.
- Open “**Wafer Properties**” from the **Edit** menu to modify simulation domain properties.
- Select “**Profiles and Materials**” from the **Edit** menu to open the **Profile Designer** where you can add and modify materials and profiles.

Now we have defined a $2\mu\text{m}\times 2\mu\text{m}$ 2D Air free space domain. We will generate a TF/SF plane wave in a rectangular region in this space. The total field region size will be $0.9\mu\text{m}\times 0.9\mu\text{m}$ in the center space. To detect the pure scattering field, we will also put four observation line detector surrounding this TF/SF generated region. Each Observation line detector will be $0.15\mu\text{m}$ apart from the each developed line.



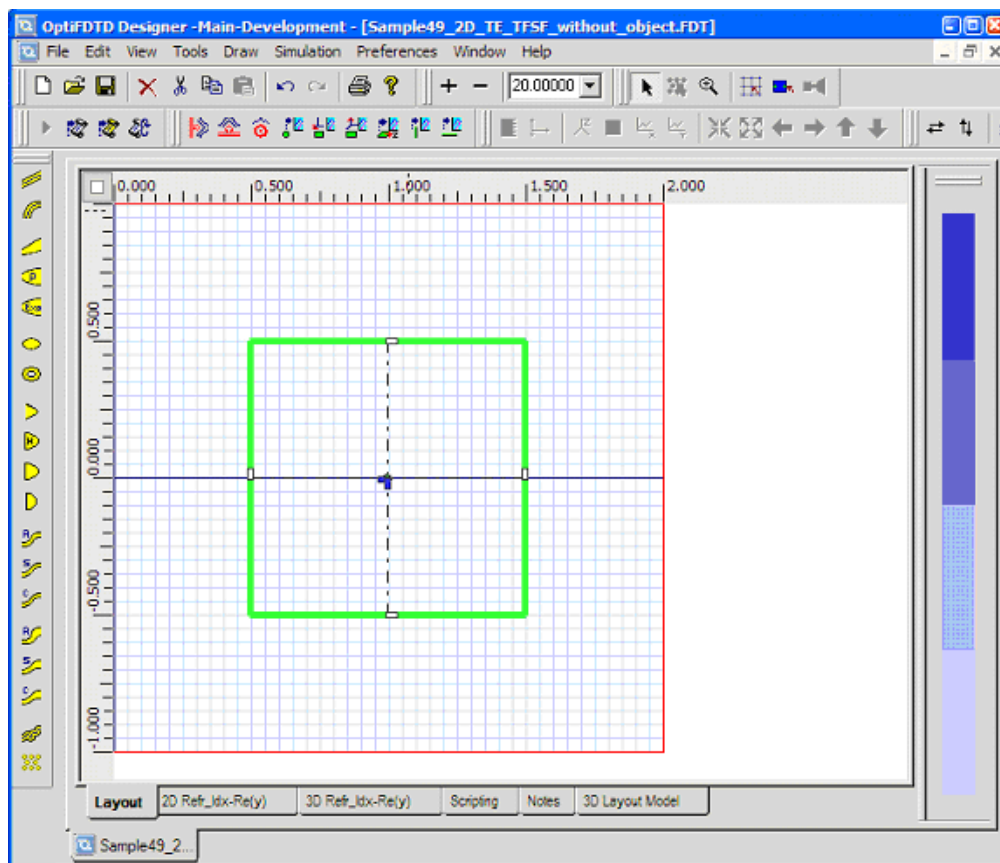
Define Input Wave

To insert the TF/SF plane wave excitation follow the steps below:

Step Action

- 1 From the Draw menu, select TFSF region.
- 2 Click in the layout window at the position where you want to insert the TFSF region.
A Green/red rectangular region that represents the TFSF appears in the layout window. (Figure 9)

Figure 9 Initial TFSF in the layout



- 3 To set up the TFSF Input wave properties, double-click the TFSF lines in the layout window. The **TFSF Properties** dialog box appears. Set the time domain Input Plane basic information.
 - Select Continuous Wave
 - Wavelength (um): 1.5

Note:

- Continuous Wave

The specified wavelength is a single wavelength that is used in simulations.

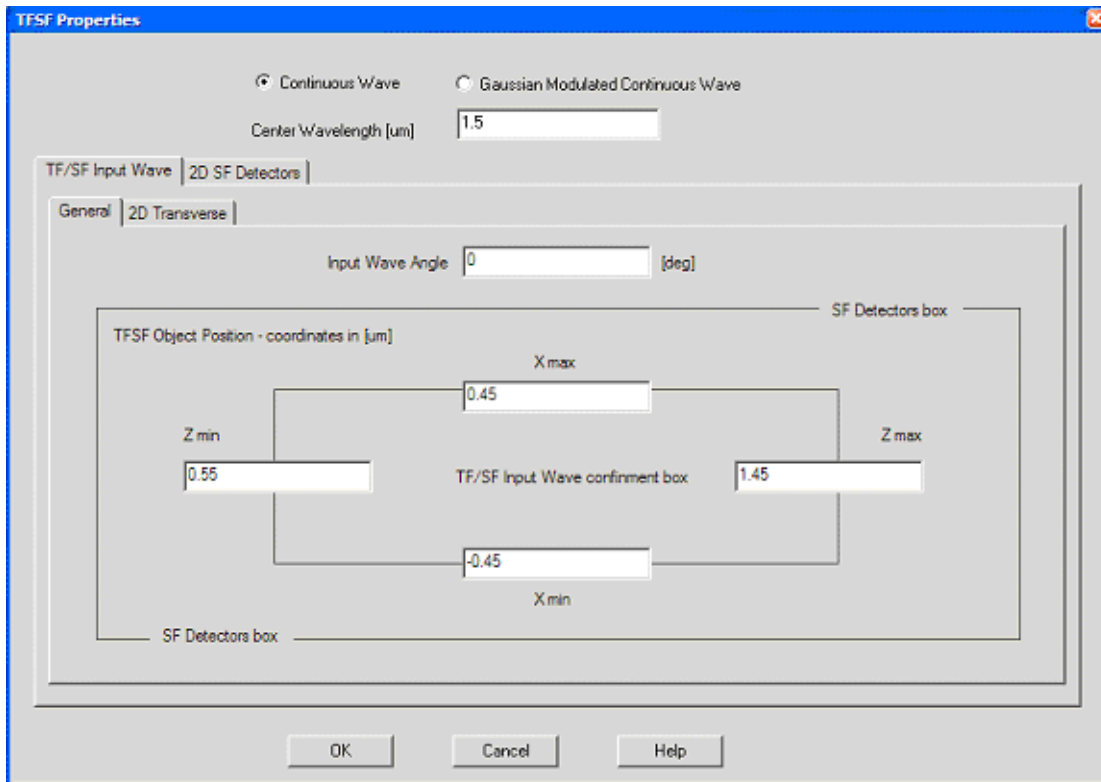
- Gaussian Modulated Continuous Wave

The specified wavelength is the carrier wavelength (center wavelength) for the pulse simulations.

4 In the **General** Tab, input the following information: (Figure 10)

- Input Wave Angle: 0.0 [deg]
- X min: -0.45 μm
- X max: +0.45 μm
- Z min: 0.55 μm
- Z max: 1.45 μm

Figure 10 General Information for TF/SD input wave



a. In the 2D Transverse Tab, input the following information:

- Effective Refractive index : Background (wafer)
- Input Amplitude or Power
Amplitude: 1.0



5 To set up the scattering field detector properties, in the **2D SF Detectors Tab**, input following information:

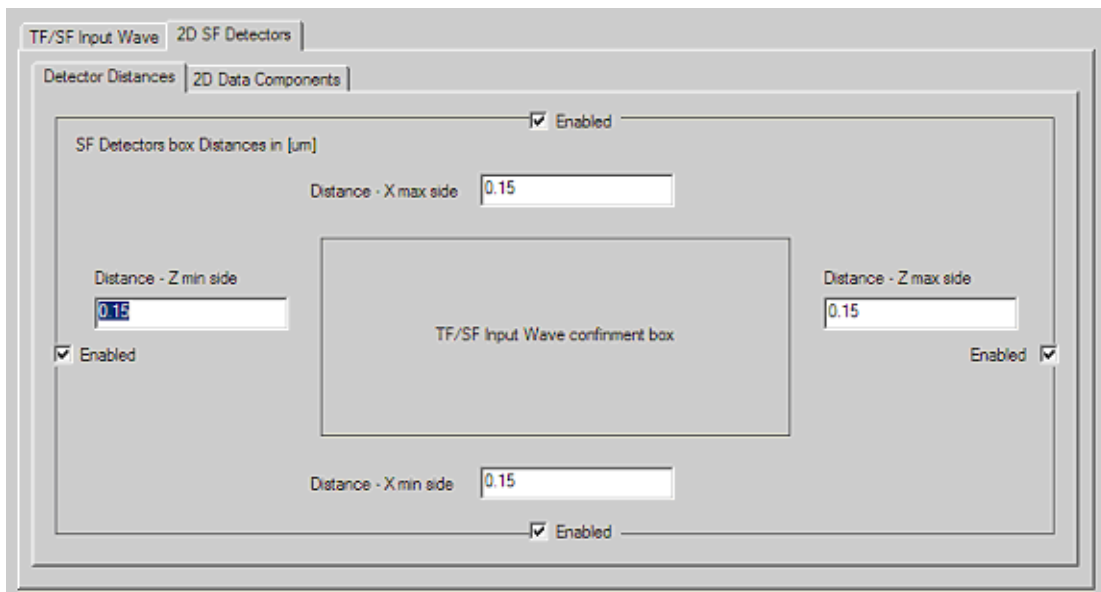
a. In the Detector Distance tab, input following information (Figure 11)

- Distance X min side: 0.15 μm , Enabled
- Distance X max side: 0.15 μm , Enabled
- Distance Z min side: 0.15 μm , Enabled
- Distance Z max side: 0.15 μm , Enabled

Note:

- Scattering field detectors are four observation lines beside the TFSF input lines, the position is determined by the distance to the input plane.
- In this case the Scattering field detector is out of the wave, this detector will be disabled.

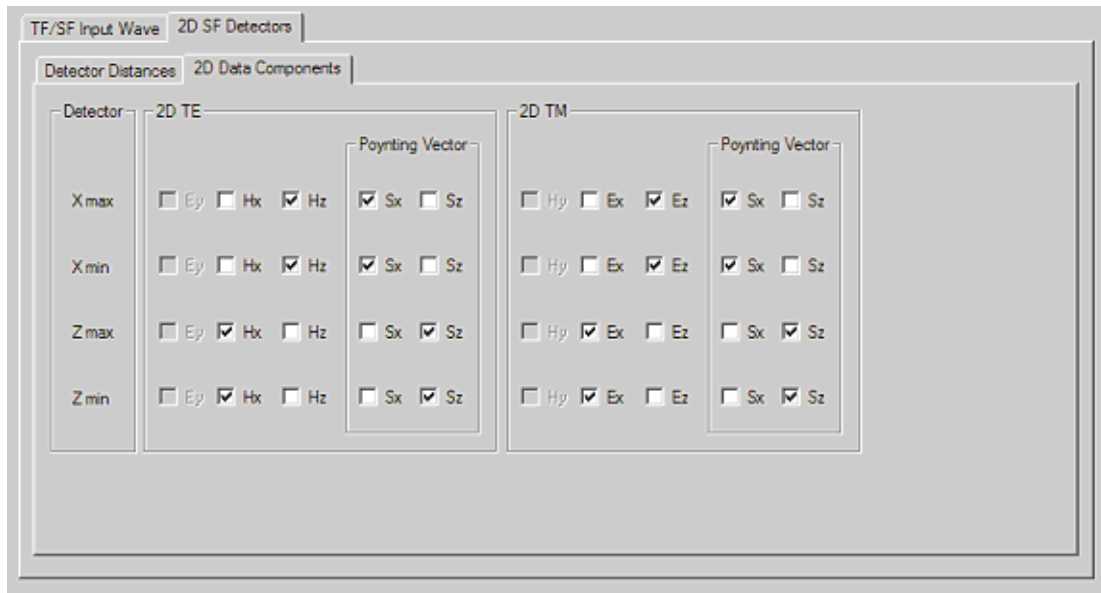
Figure 11 2D SF Detector Distance



b. In the 2D Data Components tab, input the following information (default) (Figure 12)

- For x-direction detector, Select x-direction Poynting vector S_x .
- For z-direction detector, Select z-direction Poynting vector S_z

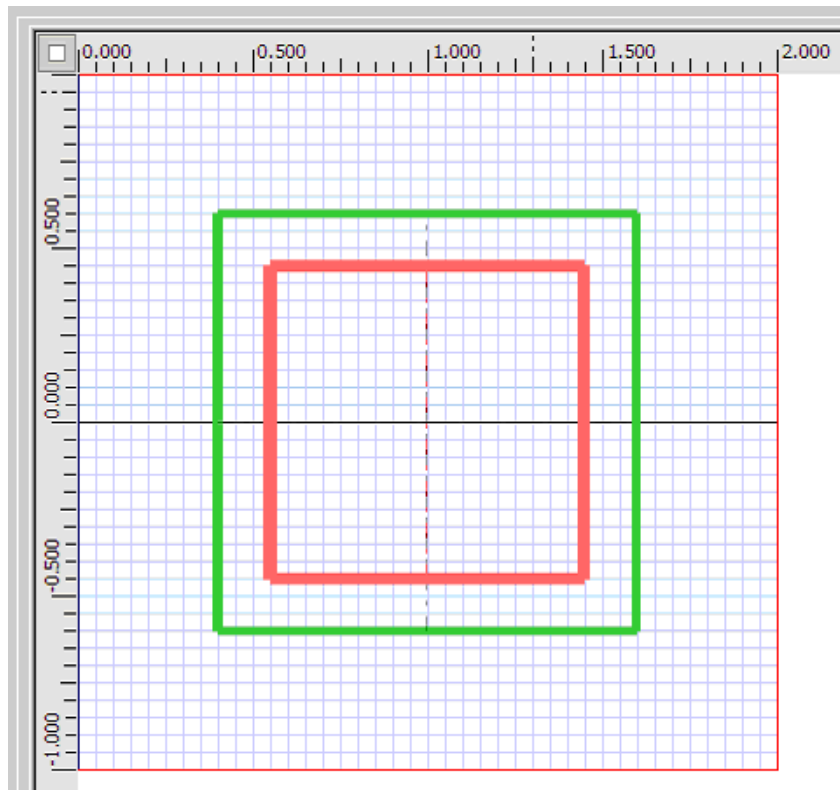
Figure 12 2D data Components for Scattering field detector



- 6 Click **OK** in TFSF Properties dialog box. A modified TFSF region appears in the layout window. (Figure 13)
- 7 Click **Save** in the file menu to save this project to a file.



Figure 13 TF/SF input plane in the layout window



Note: 2D TF/SF cannot work with other input wave type such as point source, input plane.

Define Simulation Parameters

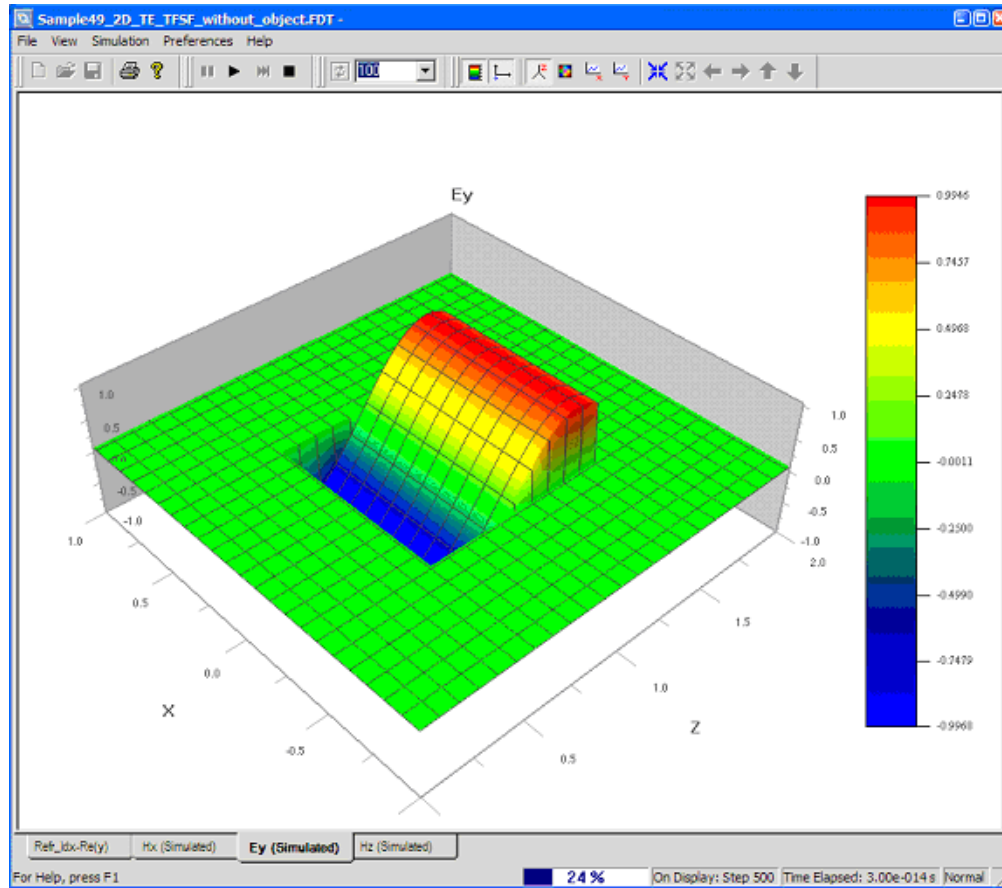
- | Step | Action |
|------|--|
| 1 | From the Simulation menu, select 2D 32bit Simulation Parameters . Simulation parameters dialog box appears |
| 2 | Select TE as the 2D simulation type |
| 3 | Turn off the auto check for Mesh Delta. Type the following values for the mesh size:
Mesh Delta X (um): 0.01
Mesh Delta Z (um): 0.01 |
| 4 | To set up the boundary condition parameters, click Advanced . <i>The Boundary Conditions dialog box appears.</i> Type the following values for the boundary condition: <ul style="list-style-type: none">• Anisotropic PML layer number: 10• Theoretical Reflection Coefficient: 1.0e-12• Real Anisotropic PML Tensor Parameter: 10.• Power of grading Polynomial: 3.5 |
| 5 | Run for 800 time steps |



Perform the 32Bit-FDTD FDTD Simulation

- | Step | Action |
|------|--|
| 1 | From the Simulation menu, select the "2D 32bit simulation parameters" |
| 2 | Click Run to start the simulation. The Simulator window appears (Figure 14). It displays the time domain response for TFSF excitation. |

Figure 14 2D Simulator window



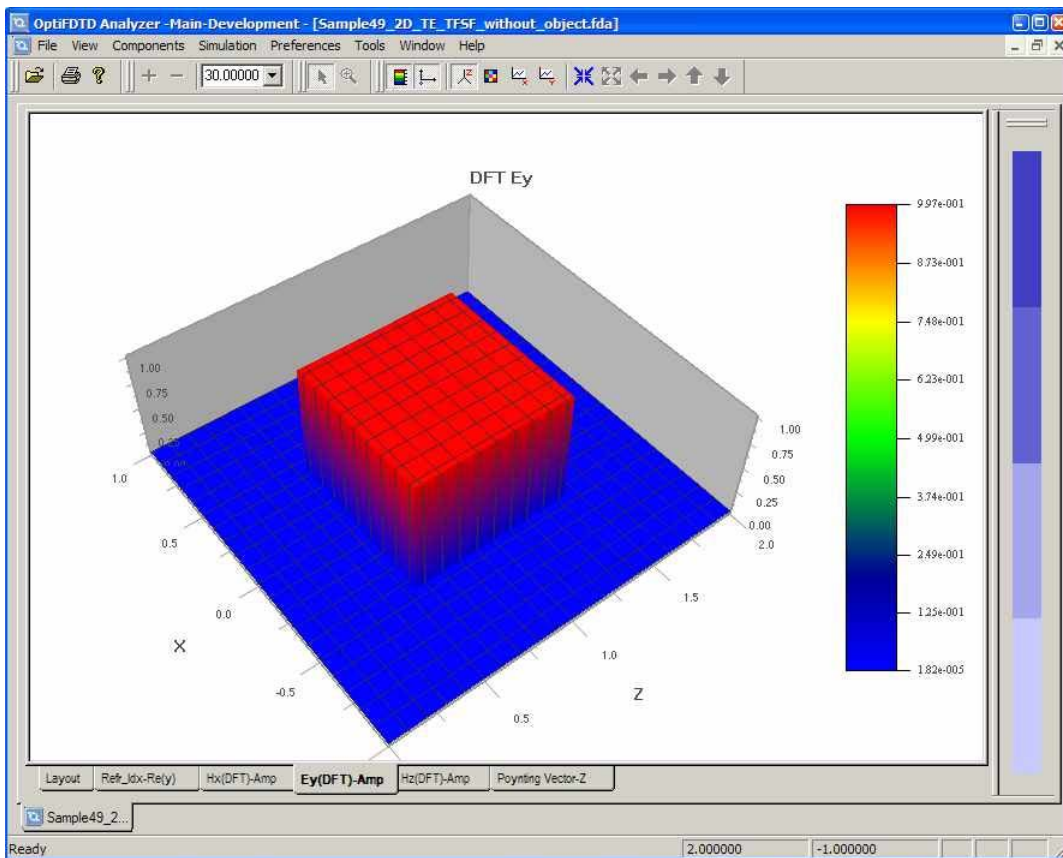
When Simulation is finished, you will be asked if you want to open the analyzer to view the results. Click **yes** to start the analyzer.

Observe Steady state response in Analyzer

Step Action

- 1 In the analyzer window, Click ***Ey(DFT) AMP*** button under the graph window to observe the steady state response for this TFSF excitation in free space (Figure 15).
- 2 Click ***Hx(DFT) AMP*** button or ***H_z(DFT) AMP*** button to Observe other field components.
- 3 In the **Components** menu, click field components and select phase will bring the phase distribution for each field component.

Figure 15 Steady state response

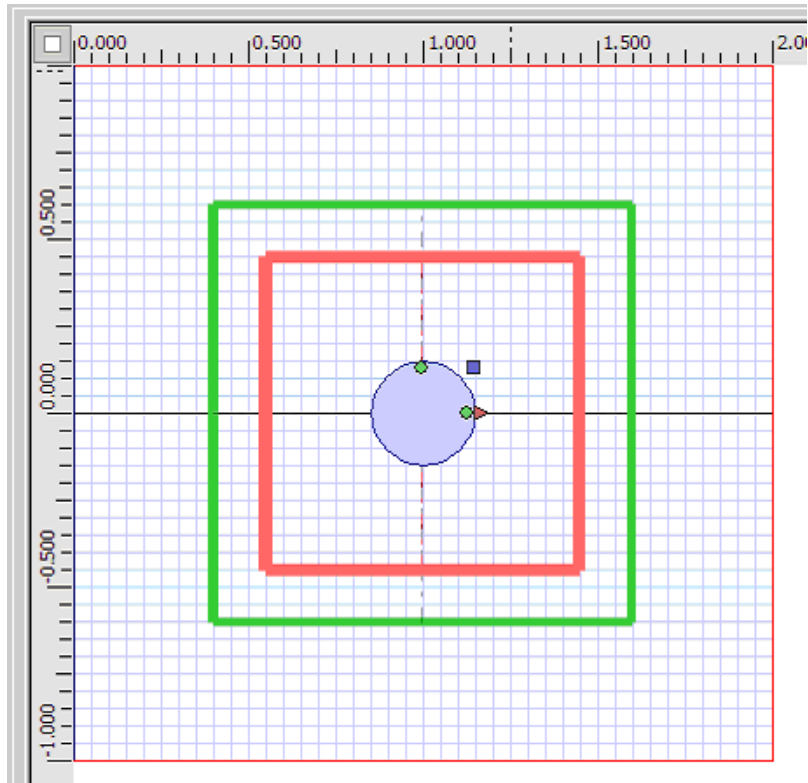


RCS calculation for an infinity cylinder

- | Step | Action |
|------|---|
| 1 | Re-open this layout in the OptiFDTD Designer. |
| 2 | Select " <i>Elliptic Waveguide</i> " under the Draw menu, or select the <i>Elliptic Waveguide</i> in the shortcut toolbar |
| 3 | Left-click and do not release the mouse to draw an elliptic waveguide in the layout. release the mouse by clicking the arrow toolbar. |
| 4 | To adjust the position and the shape of the elliptic waveguide, in the layout window, double-click the <i>Elliptic Waveguide</i> . The <i>Elliptic Waveguide Properties</i> dialog box appears. |
| 5 | In the Elliptic Waveguide Properties dialog box, input following information <ul style="list-style-type: none">• Horizontal Offset: 1.0μm• Vertical Offset: 0.0μm• Major Radius Offset: 0.15μm• Minor Radius Offset: 0.15 μm• Orientation Angle offset: 0• Channel Thickness Tapering : User default• Depth: 0.0μm• Label;'Elliptic1• ProfileChannelPro1 |
| 6 | Click OK in the <i>Elliptic Waveguide Properties</i> dialog box, the elliptic waveguide appears inside the TFSF region center. (Figure 16) |



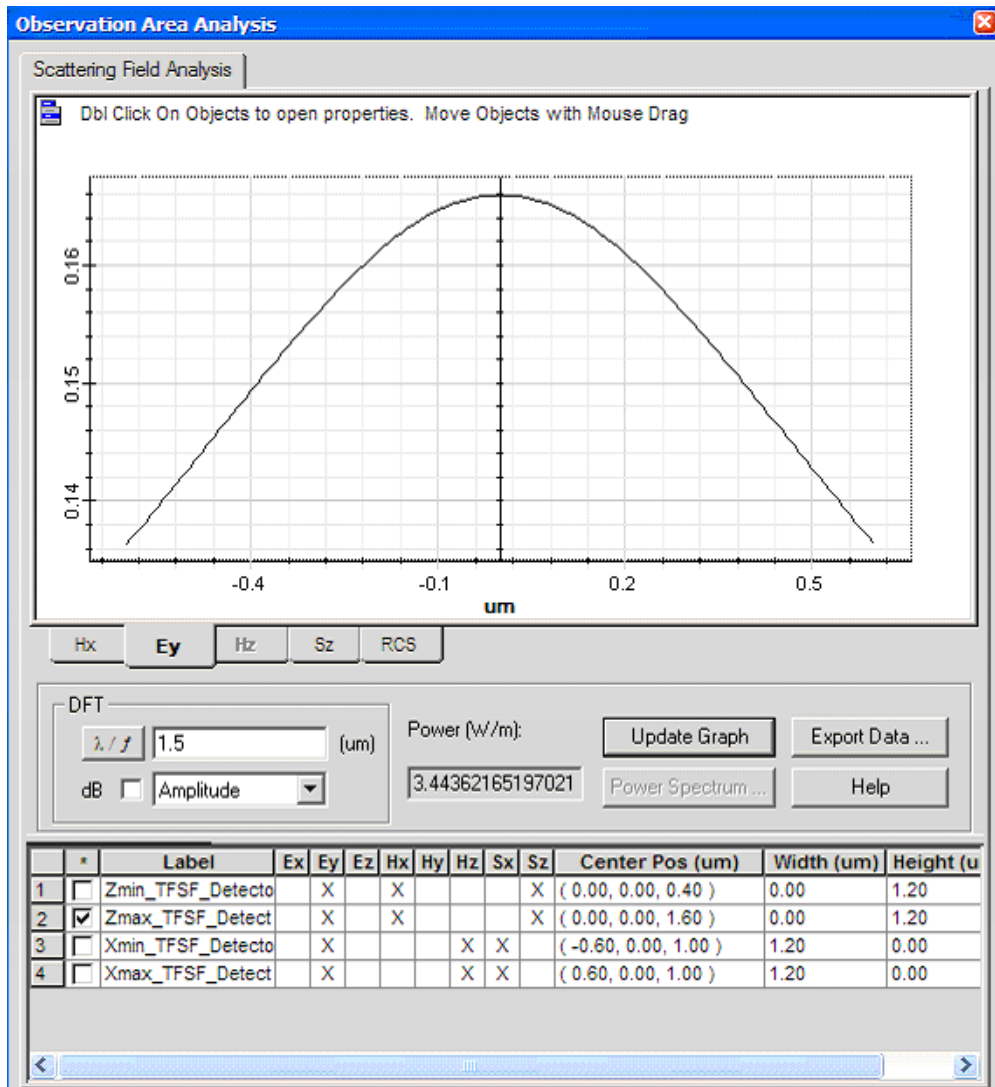
Figure 16 Elliptic waveguide in the TFSF region



- 7 Click **Save as** in the file menu to save this project to another file name.
- 8 Click **Run** in the **2D 32bit simulation parameter** dialog box to start the simulation.
- 9 After the simulation, start the analyzer.
- 10 In the analyzer, Click Observation Area Analysis under the tools menu, Observation area analysis dialog box appears.
- 11 Click **Scattering Field Analysis** tab in the Observation Area Analysis dialog box, four Scattering Field(SF) detector is listed in this dialog box, select one of them, select the field components tab. then click update graph, the pure scattering field will be displayed. (Figure 17).



Figure 17 Scattering field



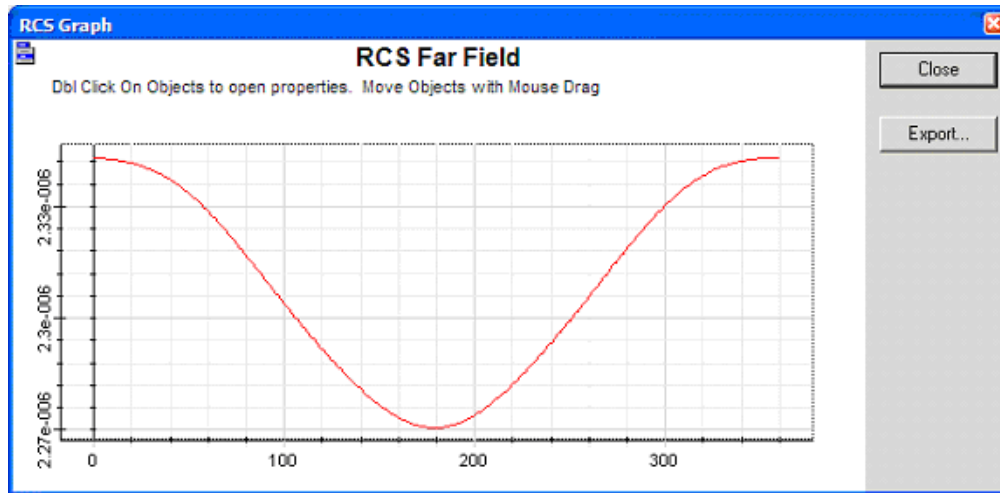
- 12 Click RCS (Radar Cross Section) tab, the input the following information (default value)
- Start angle: 0o
 - End Angle: 360o
 - Sampling Point Count: 361
 - Far field Distance: 10, 000* wavelength

Note:

- For single wavelength simulation, by default Wavelength is the center wavelength
- For Gaussian Modulated Continuous Wave (GMCW), user can input new wavelength.
- RCS far-field formula is explained in the technical background.

13 Click **Calculate** in the RCS tab page, RCS results will be displayed (Figure 10)

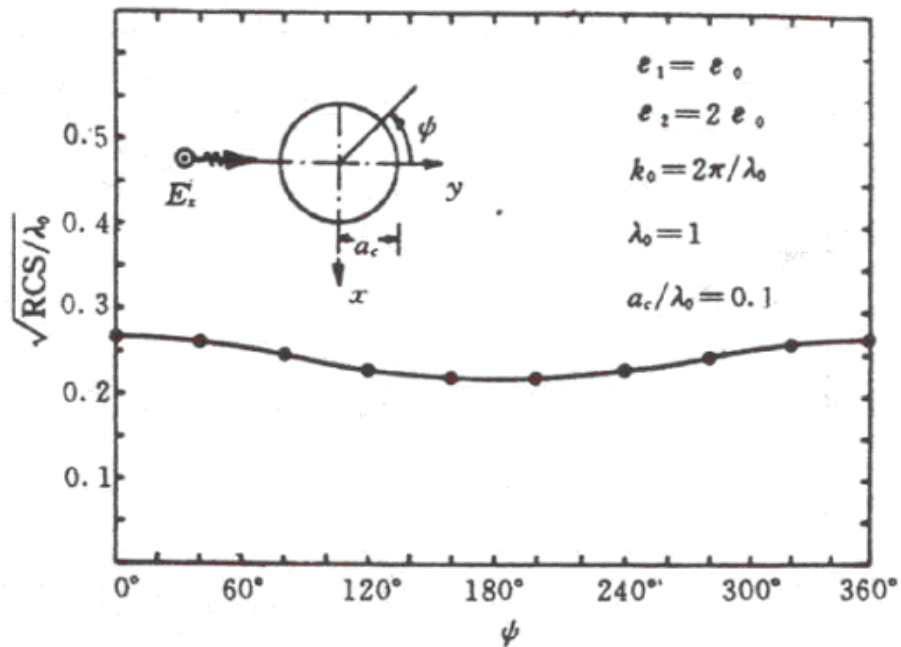
Figure 18 RCS results



Note:

- The above RCS results agreed with the results in the reference [1] as shown below (Figure 11)

Figure 19 RCS results in reference



- Click Export in RCS results dialog box can store the results to a file, RCS results file is an text file, the first three line is file header, the remaining first column is the angle, the second column is the far-field amplitude.

Reference:

- [1] Umashankar K. R, Taflove A.A "Novel method to analyze electromagnetic scattering of complex objects", IEEE Trans. On EMC, 1982, 24(4), pp. 397-450

LESSON 20 - 2D TOTAL FIELD/SCATTERING FIELD(TF/SF) SIMULATION AND RADAR CROSS SECTION(RCS) DETECTION



Lesson 21 - Simulation on 3D surface Plasmon based layout

Surface plasma wave is sensitive to the metallic material and the layout geometries. OptiFDTD provided build in time domain Lorentz_Drude for noble metals. In the following we will discuss two surface Plasmon layout simulations

Example 1 nano-gold particle simulation

In this example, we will show how a gold particle is simulated by OptiFDTD. In some surface Plasmon layouts, gold particles may distribute in an array format, if the input plane wave propagate straight forward and the array is periodic, then we can take one periodic cell for the simulation with transverse boundary set as periodic boundary condition (PBC). If single gold particle works independently, we can either set transverse boundary as absorbing condition or still set transverse boundary as PBC with simulation space is two three time larger than the nano particle size.

The sample layout can be found in the 64bit sample folder, it is named as "X64_Sample52_100nmGoldSphere_400nm_900nmPulse.fdt"

Layout Creation steps

- | Step | Action |
|------|---|
| 1 | Open OptiFDTD Waveguide layout Designer From the Start menu, select Programs ->Optiwave Software -> OptiFDTD-> Waveguide Layout Designer . OptiFDTD_Designer window opens. |
| 2 | Create a new project.
<i>From the OptiFDTD_Designer File menu, select New. The Initial Properties dialog box appears.</i> |
| 3 | Define the material(s) and waveguide profile(s) that will be used in the project. Click the Profiles and Materials button in the Initial Properties dialog. The Profile Designer OptiFDTD opens. |

Note: At any time, you can open the **Profile Designer** from the "**Edit->Profiles and Materials...**" menu of the **Layout Designer** or from the **Start** menu. So you can make appropriate modifications to the defined materials and profiles whenever it is needed.

- a. In the material folder of **Master**. Find build in gold material "**Gold_Au_Lorentz_Drude_Model**", select this material and drag it to **FDTD-Dispersive** folder under **Materials** folder of current project **OptiFDTD_Designer1**, Click **Store** button in the **Gold_Au_Lorentz_Drude_Model** dialog box to save this material to the project.
- b. In the directory under **OptiFDTD_Designer1**, under the **Profiles** folder, right click the **Channel** folder. A context menu appears. Select **New**. The **Channel Profile** dialog box appears. Type the following information:



- Profile name: **ChannelPro1**
 - Under 3D profile definition: Type the following information:
 - Layer name: **Layer1**
 - Width: **0.1**
 - Thickness: **0.1**
 - Offset: **0.0**
 - In the Material list, select **Gold_Au_Lorentz_Drude_Model**
 - Click Add.
 - To save the channel profile, click **Store**.
- ChannelPro1** appears in the **Channel** folder.
- 4 Return to **Initial Properties** dialog box of **Waveguide Layout Designer**. Either minimize or close the Waveguide Profile Designer.
 - 5 Type the following information in each corresponding area in **Initial Properties** dialog box
 - **Waveguide Properties:**
 - Width (μm): **0.1**
 - Profile: **ChannelPro1**
 - **Wafer Dimension**
 - Length (μm): **0.6** (z-direction dimension)
 - Width (μm): **0.3** (x-direction dimension)
 - **3D Wafer Properties**
 - Cladding Material: **Air**
 - Cladding Thickness: **0.3**(y-direction dimension)
 - Substrate Material: **Air**
 - Substrate Thickness: **0** (y-direction dimension)
 - 6 Click **OK** in **Initial Properties** dialog box. **OptiFDTD Designer-[OptiFDTDigner1]** window appears.
- Note:**
- If not all Toolbars appear in the Layout Designer window, you can change it from the “**View-Toolbars**” menu option.
 - Click “**+**” (zoom) toolbar button to enlarge the layout window.
 - Open “**Wafer Properties**” from the **Edit** menu to modify simulation domain properties.
 - Select “**Profiles and Materials**” from the **Edit** menu to open the **Profile Designer** where you can add and modify materials and profiles.
- 7 Draw a nano-particle in the layout.
 - Select sphere under the 3D shapes of Draw menu.
 - Click the mouse in the layout where the particle should be put. (Change the mouse drawing tool by selecting the arrow shortcut icon on the toolbar)



- To adjust the position and the shape of the waveguide, in the layout window, double-click the sphere. The **Sphere Waveguide Properties** dialog box appears
- In the sphere waveguide properties dialog box, type the following values
 Position x: **0**
 Position y: **0.15 (m)**
 Position z: **0.35 (m)**
 Radius: **0.05 (m)**
 Label: **Sphere1**
 Material: **Gold_Au_Lorentz_Drude_Model**
- Click **OK** to finished the sphere setting

Note:

You can parameterize the waveguide by entering a user-defined variable (parameter) in the **Expression** field. The expression fields are marked with "**fx**". For example you can enter StartPosZ (or an expression like 2*StartPosZ), in the **Expression** field of **Horizontal** position definition. After that press the **Evaluate** button, to see the resulting **Position** value. If the specified parameter has not been defined, then the software will prompt you to define it.

- 8 Click **3D Layout Model** tab under the layout window to observe the layout in 3D mode (see [Figure 1](#))

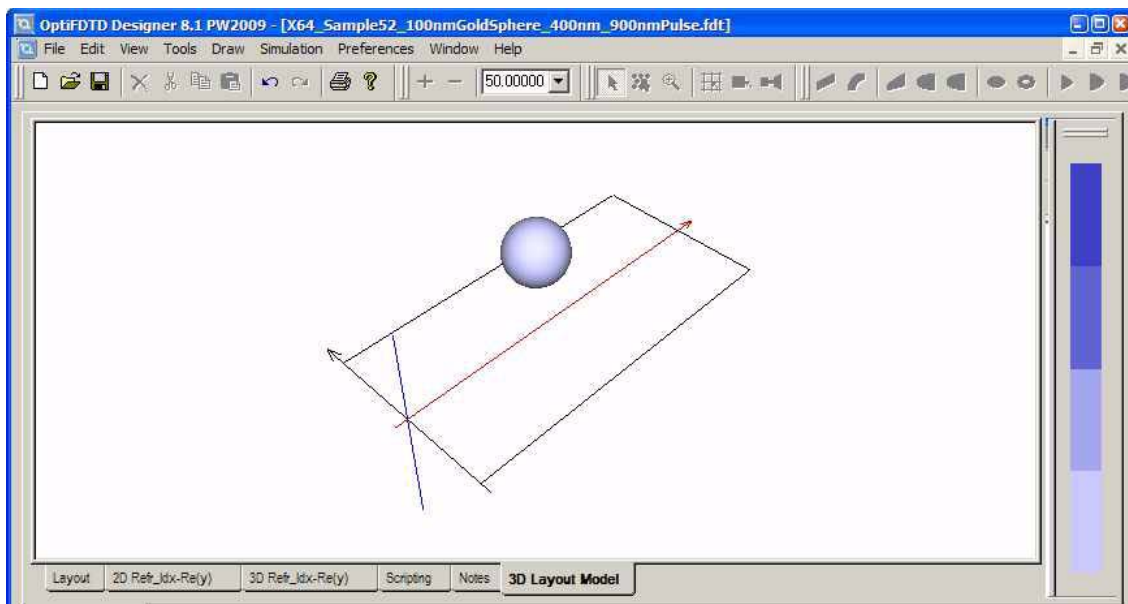


Figure 1 3D layout mode for sphere

Define Input Wave

The Input Wave signal is defined within the Input Plane. To insert the Input Plane and set the excitation wave, follow the steps below:

- | Step | Action |
|------|---|
| 1 | From the Draw menu, select Vertical Input Plane , or select Vertical Input Plane shortcut toolbar (The Vertical Input Plane is in the x-y plane for 3D.) |
| 2 | Click in the layout window at the position where you want to insert the Input Plane. <i>A red line that represents the input plane appears in the layout window.</i> |
| 3 | To set up the Input Plane properties, double-click the red line (Input Plane) in the layout window. <i>The Input Field Properties dialog box appears.</i> |
| 4 | Set the time domain Input Plane basic information. <ol style="list-style-type: none"> Select Gaussian Modulated Continuous Wave.
The Gaussian Modulated CW tab appears. Wavelength (μm): 0.55(μm) |

Note:

- Continuous Wave: Wavelength is a single wavelength that is used in simulations.
- Gaussian Modulated Continuous Wave: Wavelength is the carrier wavelength (center wavelength) for the pulse simulations.

- | | |
|---|--|
| 5 | Click the Gaussian Modulated CW tab to set the time domain input waveform. <i>The time domain pulse graphics appear.</i> Type the following values for the time domain input plane
Time offset (sec.): 4.0e-15
Half width (sec.): 0.8e-15 |
|---|--|

Note:

- Right Click on the graph and select the **Zoom In** tool to enlarge the selected graph region. You can observe the bandwidth in this way.
- Adjust half width can adjust the bandwidth

- | | |
|---|---|
| 6 | To set up the general information (transverse field distribution) for the Input Plane, click the General tab
Input Field Transverse: Rectangular(windowed plane wave)
Z Position (μm): 0.2
Plane Geometry: Positive direction
Label: InputPlane1 (default) |
| 7 | Click 3D Transverse to setup the plane wave setting <ul style="list-style-type: none"> • Center Position X: 0.0 (μm); Halfwidth X: 0.2 (μm) • Center Position Y: 0.15 (μm); Halfwidth Y: 0.2 (μm) • Effective index: Local • Polarization: Linear Y |



- Amplitude: $1.0 \text{ (V/m}^2\text{)}$

To complete the Input plane setup, click OK.

Define Simulation Parameters

- | Step | Action |
|------|--|
| 1 | From the Simulation menu, select Simulate 3D Using 64-bit Simulator .
<i>The 3D Simulation Parameters dialog box appears.</i> |
| 2 | In the mesh size region unselect “Auto” boxes, type the following values for the mesh size:
Mesh Delta X (m): 0.004
Mesh Delta Y (m): 0.004
Mesh Delta Z (m): 0.004 |
| 3 | To set up the boundary condition parameters, click Advanced . <i>The Boundary Conditions dialog box appears.</i> <ul style="list-style-type: none"> • Set X and Y direction boundary condition as PBC • Set Z direction boundary condition as APML • Type the following values for the PML boundary condition:
Anisotropic PML layer number: 16
Theoretical Reflection Coefficient: 1.0e-12
Real Anisotropic PML Tensor Parameter: 60.0
Power of grading Polynomial: 3.5 |
| 4 | Run for 4000 time steps |
| 5 | Time sampling interval: 2 |

Note:

- Time steps size
The default value ensures stability and accuracy of FDTD simulations
 - Time step number
The default value ensures that the wave completes propagation through the whole layout
 - Time sampling interval
This sampling rate applies to observation areas. It determines how many time domain response sample points are used for the spectrum calculation.
- 6 Click the “**Spectrum**” button to set the spectrum range
- Set “**Number of Samples**” to 101,
 - Uncheck the “**Auto**” checkbox,
 - Check the “Use Wavelength” radio button
 - Set Start wavelength as $0.4 \mu\text{m}$
 - Set end wavelength as $0.9 \mu\text{m}$
 - and press Ok button to accept changes



ctangular(windowed plane wave)

Z Position (μm): **0.2**

Plane Geometry: **Positive direction**

Setup the Observation Objects (result data-detector)

For the 32-Bit FDTD simulation, observation objects will record all the time domain response so that spectrum analysis can be performed in analyzer. For 64-Bit FDTD simulation, Observation points will still record all the time domain response in each single point, but Observation area will perform the spectral analysis in simulator and save the spectrum DFT results to the analyzer file. For 64bit FDTD simulation,

Observation Points or Observation Area must be present; otherwise simulations will not store any results for further analysis.

- **Observation Point**

Observes the time domain and frequency domain response. The transmission function can be obtained from the Observation Point analysis.

- **Observation Area**

It is used to compute power transmission ratio, and normalized power (power transmission /reflection) versus wavelength.

Step	Action
1	From the Draw menu (or the shortcut toolbar), select Observation XY Area.
2	Place the Observation XY Plane in the position after the sphere in the layout.
3	Double-click the observation XY Area. <i>The “Observation Properties – X-Y Area” dialog box appears.</i> Type the following values in the dialog box
	General
	Center Horizontal Offset (z-drection): 0.5(μm)
	Center Vertical Offset(x-direction): 0.0(μm)
	Center depth (y-direction): 0.15 (μm)
	X-Length 0.3 (μm)
	Y-Length 0.3 (μm)
	Label: ObservationArea1
	Data Components
	Ex, Ey, Hx, Hy
4	Click OK to close the dialog box
5	Repeat steps 1 to 4 to design another Observation area with center horizontal offset at $z=0.1 \mu m$
	General
	Center Horizontal Offset (z-drection): 0.1(μm)
	Center Vertical Offset(x-direction): 0.0 μm)
	Center depth (y-direction): 0.15 (m)



X-Length **0.3 (m)**

Y-Length **0.3 (m)**

Label: **ObservationArea2**

Data Components

Ex, Ey, Hx, Hy

Note: Observation1 will get the power spectral transmission function, Observation 2 is behind input plane and it will get the power spectral reflection function.

- 6 In the same manner we can put observation point in the layout.

Perform the 64Bit-FDTD Simulation

- | Step | Action |
|------|--|
| 1 | From the Simulation menu, select the “ Simulate 3D using 64-Bit Simulator... ” option. <i>The 3D Simulation Parameters dialog box appears.</i> |
| 2 | Click Run to start the simulation. The progress window appears, it displays the status of the simulations. |
| 3 | Visualization of intermediate simulation results. configure the snapshot settings. In the calculation progress window, select “ Simulation ->Take Snapshot ” menu option. The “ Set Snapshot ” dialog box appears <ul style="list-style-type: none"> • Click Browse to select the location of the output file • Check the observation areas or observation points. The time domain response in the selected observation objects for the current time-step will be save to the file • Click OK to close this dialog box |
| 4 | Click the “ Take Snapshot ” button in the simulation progress dialog box to save the time domain response in the current displayed time step |
| 5 | Go to the folder where the snapshot is saved and with 2D or 3D Viewer observe the time domain response for a certain time step |

When the simulation is finished, you will be asked if you want to open the analyzer to view the results. Click **yes** to start the analyzer

Post-Simulation Data Analysis

- | Step | Action |
|------|---|
| 1 | Select "Observation Area Analysis" under the "Tools" menu in the Analyzer. Select Observation area button to active observation area analysis, Observation Area dialog box appears |
| 2 | Select " ObservationArea1 " in the observation area check list |
| 3 | Select Ey component. |
| 4 | Select wavelength 0.8 from the λ/f list box |
| 5 | Click Update Graph (see Figure 2) |
| 6 | Select Power Spectrum button, Power Spectrum dialog box appears, Select total Power "Pz", Check " normalize with " checkbox and click Calculate button, PowerTransmission spectrum appears, (refer to Figure 3) |

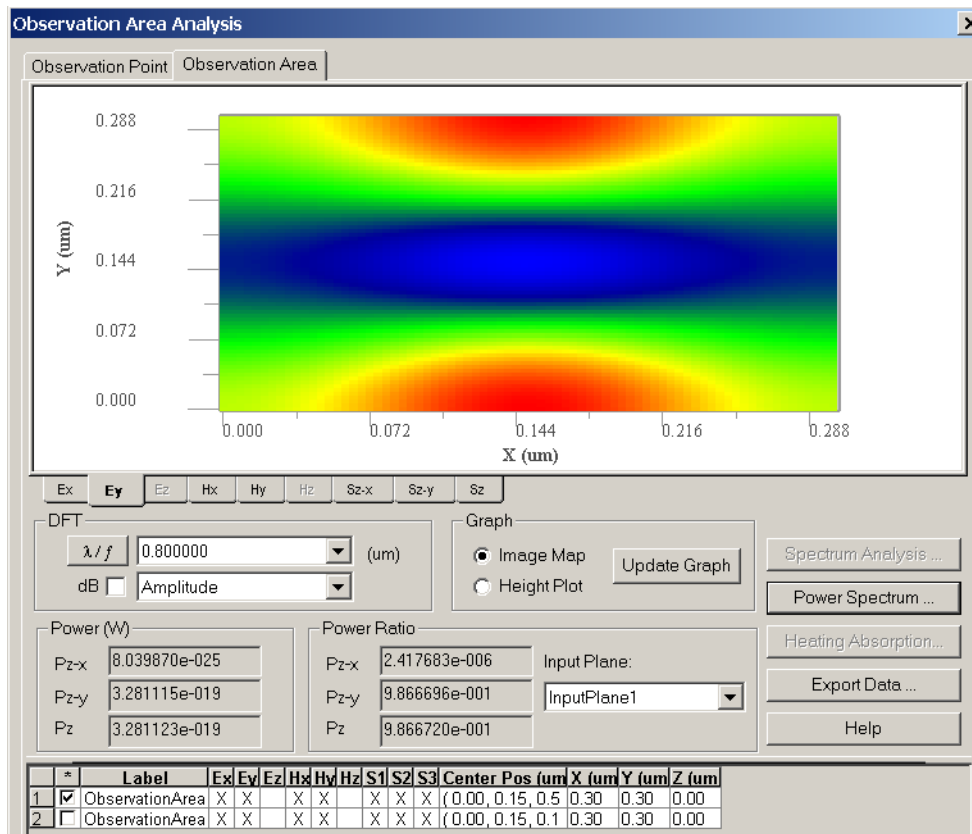


Figure 2 field pattern in observation area.



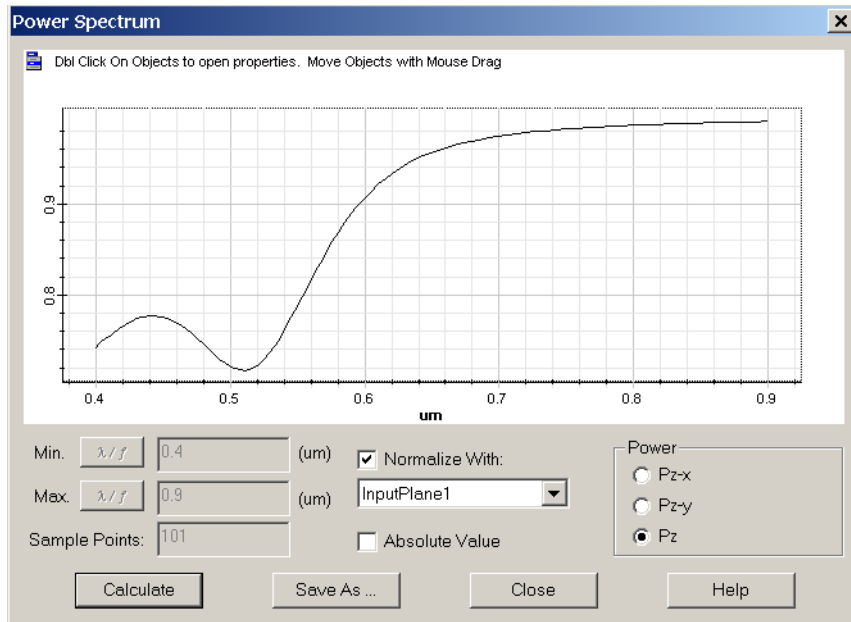


Figure 3 Power transmission function

Note: Some researchers may check the extinction ratio from Mie theory for nanoparticle. Power transmission in this sample has the reverse properties compared with extinction ratio (see Figure 4)

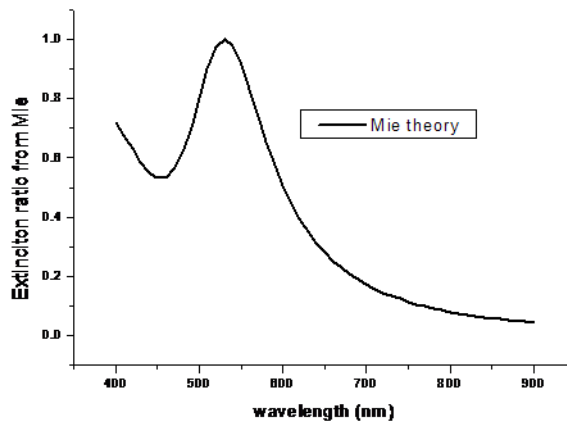


Figure 4 Extinction ratio from Mie theory

Example 2 Simulate Sub wavelength holes in metallic film

It is generally accepted that the enhanced transmission is mediated by surface plasmon polaritons (SPPs) that exhibit resonances set up by the periodicity of the array. We will calculate the transmission through sub-wavelength holes in a gold film deposited in SiO₂ substrate. Surface Plasmon wave that results from the periodic array of holes will enhance the transmission in a certain wavelength region. The original layout is shown in figure 5. It is periodic square-air-hole arrays that were created by ion milling in optically thick Au films (200 nm) deposited on glass. All arrays investigated have a period of 425 nm. The width of the square holes is varied (148nm, 165nm, 187nm, 196nm, 231nm, 247nm, 286nm). In this simulation the initial input plane wave will propagate to z-direction, so we can just pick up one unit cell for the simulation with x and y boundary set as PBC. This will save the simulation time.

The sample layout can be found in the 64bit sample folder, it is named as "X64_Sample53_HolesInGoldFilm_Pulse500nm_1000nm.FDT"

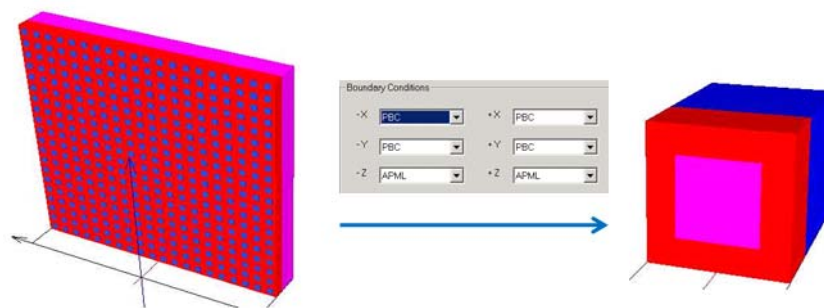


Figure 5 Original layout and single cell layout

The following will show:

- 1) How to create the layout with variable.
- 2) How to setup variable to sweep the hole's size.
- 3) How to perform the variable sweep simulation.

Layout Creation steps

- | Step | Action |
|------|--|
| 1 | Open OptiFDTD Waveguide layout Designer
From the Start menu, select Programs ->Optiwave Software -> OptiFDTD-> Waveguide Layout Designer . OptiFDTD_Designer window opens. |
| 2 | Create a new project.
From the OptiFDTD_Designer File menu, select New . The Initial Properties dialog box appears. |



- 3 Define the material(s) and waveguide profile(s) that will be used in the project.

Click the **Profiles and Materials** button in the **Initial Properties** dialog. The **Profile Designer OptiFDTD** opens.

Note: At any time, you can open the **Profile Designer** from the “**Edit->Profiles and Materials...**” menu of the **Layout Designer** or from the **Start** menu. So you can make appropriate modifications to the defined materials and profiles whenever it is needed.

- a. In the material folder of **Master**. Find build in gold material “**Gold_Au_Lorentz_Drude_Model**”, select this material and drag it to **FDTD-Dispersive** folder under **Materials** folder of current project **OptiFDTD_Designer1**. Click **Store** button in the **Gold_Au_Lorentz_Drude_Model** dialog box to save this material to the project.
- b. In the In the directory under **OptiFDTD_Designer1** of **Profile Designer OptiFDTD**, under **Materials** folder, right-click the **Dielectric** folder. A *context menu appears*. Select **New**, the **Dielectric** dialog box appears. By default the constant refractive index (**Const Ref. Idx**) is selected. Type the following information

Name: **n=1.5**

Constant refractive index (isotropic) (Re): **1.5**

Click Store to save this material, Material n=1.5 will be listed under the **FDTD-Dielectric** folder

(the following sub-step c-d is to design the waveguide cross-section that will be used in the layout.)

- c. In the directory under **OptiFDTD_Designer1**, under the **Profiles** folder, right click the **Channel** folder. A context menu appears. Select **New**. The **Channel Profile** dialog box appears. Type the following information:
 - Profile name: **Channel_Au**
 - Under 3D profile definition: Type the following information:
 Layer name: **Layer1**
 Width: **0.425**
 Thickness: **0.425**
 Offset: **0.0**
 - In the Material list, select **Gold_Au_Lorentz_Drude_Model**
 - Click Add.
 - To save the channel profile, click **Store**.
Channel_Au appears in the **Channel** folder.
- d. In the directory under **OptiFDTD_Designer1**, under the **Profiles** folder, right click the **Channel** folder. A context menu appears. Select **New**. The **Channel Profile** dialog box appears. Type the following information:
 - Profile name: **Channel_Air**
 - Under 3D profile definition: Type the following information:
 Layer name: **Layer1**
 Width: **0.2**

Thickness: **0.2**

Offset: **0.0**

- In the Material list, select **Air**
- Click Add.
- To save the channel profile, click **Store**.

Channel_Air appears in the **Channel** folder.

- e. In the directory under **OptiFDTD_Designer1**, under the **Profiles** folder, right click the **Channel** folder. A context menu appears. Select **New**. The **Channel Profile** dialog box appears. Type the following information:

- Profile name: **Channel_SiO2**
- Under 3D profile definition: Type the following information:

Layer name: **Layer1**

Width: **0.425**

Thickness: **0.425**

Offset: **0.0**

- In the Material list, select **n=1.5**
- Click Add.
- To save the channel profile, click **Store**.

Channel_SiO2 appears in the **Channel** folder

- 4 Return to **Initial Properties** dialog box of **Waveguide Layout Designer**. Either minimize or close the Waveguide Profile Designer.

- 5 Type the following information in each corresponding area in **Initial Properties** dialog box

- **Waveguide Properties:**

Width (μm): **0.2**

Profile: **Channel_SiO2**

- **Wafer Dimension**

Length (μm): 1.0 (z-direction dimension)

Width (μm): **0.425** (x-direction dimension)

- **3D Wafer Properties**

Cladding Material: **Air**

Cladding Thickness: **0.425**(y-direction dimension)

Substrate Material: **Air**

Substrate Thickness: **0** (y-direction dimension)

- 6 Click **OK** in **Initial Properties** dialog box. **OptiFDTD Designer-[OptiFDTDigner1]** window appears.

Note:

- If not all Toolbars appear in the Layout Designer window, you can change it from the “**View-Toolbars**” menu option.
- You can click “**+**” (zoom) toolbar button to enlarge the layout window.



- You can open “**Wafer Properties**” from the **Edit** menu to modify simulation domain properties.
- Select “**Profiles and Materials**” from the **Edit** menu to open the **Profile Designer** where you can add and modify materials and profiles.

7 Define an variable that will be used as the hole’s width

- Select **Edit Parameters** under **Simulation** menu. Variable and Function dialog box appears
- Click **User Variable** tab, define a variable **Name** as holewidth, expression as 0.247.
- Click **Verify** button to check the expression value, click Add/Apply button to add this variable in the list
- Click **OK** to finish the variable definition

8 Draw the substrate

- Select **Linear Waveguide** shape under **Draw** menu or form the shortcut toolbar
- In the layout window, drag the linear waveguide from the start point to the end point *A linear waveguide appears in the layout window.*
- Release the **Linear Waveguide** selection tool by clicking the **Select tool** after the **Linear Waveguide** is drawn in the layout.
- To adjust the position and the shape of this linear waveguide, double-click on the drawn waveguide. *The **Linear Waveguide Properties** dialog box appears*
- In the **Linear Waveguide Properties** dialog box, type the following values

Start horizontal offset: 0.6	(z-direction start)
Start vertical offset : 0	(x-direction start)
End horizontal offset: 1.0	(z-direction start)
End vertical offset : 0	(x-direction start)

Channel thickness tapering (waveguide thickness in y-direction)

Unselect use default

Select taper type as linear

Start: 0.425

End: 0.425

Width: 0.425 (x-direction waveguide thickness)

Depth: 0 (waveguide button to the y-direction original point)

Label: Linear1

Profile: Channel_SiO2

- Click OK to close the substrate waveguide setting.

9 Draw the gold film layer

Add a linear waveguide using the previous steps outlined in step 8 and set it’s properties using the properties listed below:

Start horizontal offset: 0.4 (z-direction start)
Start vertical offset : 0 (x-direction start)
End horizontal offset: 0.6 (z-direction start)
End vertical offset : 0 (x-direction start)

Channel thickness tapering (waveguide thickness in y-direction)

Unselect use default
Select taper type as linear
Start: 0.425
End: 0.425

Width: 0.425 (x-direction waveguide thickness)
Depth: 0 (waveguide button to the y-direction original point)
Label: Linear2
Profile: Channel_Au

10 Draw the square Air hole.

Follow the same manner in step 8 to design the Square Air hole with the following information

Start horizontal offset: 0.399 (z-direction start)
Start vertical offset : 0 (x-direction start)
End horizontal offset: 0.6 (z-direction start)
End vertical offset : 0 (x-direction start)

Channel thickness tapering (waveguide thickness in y-direction)

Unselect use default
Select taper type as linear
Start: holewidth
End: holewidth

Width: holewidth (x-direction waveguide thickness)
Depth: $0.425/2 - \text{holewidth}/2$ (waveguide button to the y-direction original point)
Label: Linear3
Profile: Channel_Air

Note:

- You can parameterize the waveguide by entering a user-defined variable (parameter) in the **Expression** field. The expression fields are marked with "**fx**". For example you can enter StartPosZ (or an expression like $2 * \text{StartPosZ}$), in the **Expression** field of **Horizontal** position definition. Press the **Evaluate** button, to see the resulting **Position** value. If the specified parameter has not been defined, the software will prompt you to define it.



- 11 Click **3D Layout Model** button under the layout window to observe the layout in 3d Mode
- Right click and move the mouse will move the graph center
 - Right click and move the mouse will change the will angle
 - Roll the mouse will zoom in and zoom out the graph.

Design VB script code to Scan the hole width

In the above step 10 we connected the Air hole dimension with the defined variable “holewidth”, In this section we will use a simple VB code to scan this variable.

- 1 Click **Scripting** Button under the Layout window. VB scripting page appears
- 2 Copy the following VB code to this page.

```

dim dWit
For i=1 to 6
  select case i
    case 1
      dWit=0.148
    case 2
      dWit=0.165
    case 3
      dWit=0.187
    case 4
      dWit=0.196
    case 5
      dWit=0.231
    case 6
      dWit=0.247
    case 7
      dWit=0.266
  end select
  ParamMgr.SetParam "holewidth", dWit
  WGMgr.Sleep 500
  ParamMgr.Simulate
Next

```

Note: The above code has six iterations, each iteration set a defined variable “holewidth” with a new value “dWit”

- 3 Click Layout button under the layout window to observe the layout.
- 4 Click **Test Script** under Simulation Menu or click Play shortcut toolbar. This will run the VB code. A changing hole size will be observed in the layout window,



Note:

- VB Script in OptiFDTD is a powerful tool for designing layout, scanning parameters, or even post-data analysis. For more details about VB script, please have a look on VB script reference or tutorial lesson15-16.

Define Input Wave

The Input Wave signal is defined within the Input Plane. To insert the Input Plane and set the excitation wave, follow the steps below:

- | Step | Action |
|--------------|---|
| 1 | From the Draw menu, select Vertical Input Plane , or select Vertical Input Plane shortcut toolbar (The Vertical Input Plane is in the x-y plane for 3D.) |
| 2 | Click in the layout window at the position where you want to insert the Input Plane. <i>A red line that represents the input plane appears in the layout window.</i> |
| 3 | To set up the Input Plane properties, double-click the red line (Input Plane) in the layout window. <i>The Input Field Properties dialog box appears.</i> |
| 4 | Set the time domain Input Plane basic information. <ul style="list-style-type: none"> a. a. Select Gaussian Modulated Continuous Wave.
The Gaussian Modulated CW tab appears. b. b. Wavelength (μm): 0.68(μm) |
| 5 | Click the Gaussian Modulated CW tab to set the time domain input waveform. <i>The time domain pulse graphics appear.</i> Type the following values for the time domain input plane
Time offset (sec.): 0.8e-14
Half width (sec.): 0.1e-14 |
| Note: | |
| | <ul style="list-style-type: none"> • Right Click on the graph and select the Zoom In tool to enlarge the selected graph region. You can observe the bandwidth in this way. • Adjust half width can adjust the bandwidth |
| 6 | To set up the general information (transverse field distribution) for the Input Plane, click the General tab
Input Field Transverse: Rectangular(windowed plane wave)
Z Position (μm): 0.2
Plane Geometry: Positive direction
Label: InputPlane1 (default) |
| 7 | Click 3D Transverse to setup the plane wave setting <ul style="list-style-type: none"> • Center Position X: 0.0 (μm); Halfwidth X: 0.5(μm) • Center Position Y: 0.4125 (μm); Halfwidth Y: 0.5(μm) • Effective index: Local • Polarization: Linear Y |



- Amplitude: 1.0 (V/m²)
- 8 To complete the Input plane setup, click **OK**.

Define Simulation Parameters

- | Step | Action |
|------|--|
| 1 | From the Simulation menu, select Simulate 3D Using 64-bit Simulator .
<i>The 3D Simulation Parameters dialog box appears.</i> |
| 2 | Type the following values for the mesh size:
Mesh Delta X (m): 0.005
Mesh Delta Y (m): 0.005
Mesh Delta Z (m): 0.005 |
| 3 | To set up the boundary condition parameters, click Advanced . <i>The Boundary Conditions dialog box appears.</i> <ul style="list-style-type: none"> • Set X and Y direction boundary condition as PBC • Set z direction boundary condition as APML • Type the following values for the PML boundary condition:
 Anisotropic PML layer number: 20
 Theoretical Reflection Coefficient: 1.0e-12
 Real Anisotropic PML Tensor Parameter: 70.0
 Power of grading Polynomial: 3.5 • Click OK to save changes |
| 4 | Run for 12000 time steps |
| 5 | Time sampling interval: 2
response sample points are used for the spectrum calculation. |
| 6 | Click the " Spectrum " button to set the spectrum range <ul style="list-style-type: none"> • Set "Number of Samples" to 101, • Uncheck the "Auto" checkbox, • Check the "Use Wavelength" radio button • Set Start wavelength as 0.5um • Set end wavelength as 1.0um • and press Ok button to accept changes |
| 7 | Click Ok button to accept the specified simulation parameters |

Setup the Observation Objects (result data-detector)

For the 32-Bit FDTD simulation, observation objects will record all the time domain response so that spectrum analysis can be performed in analyzer. For 64-Bit FDTD simulation, Observation points will still record all the time domain response in each single point, but Observation area will perform the spectral analysis in simulator and save the spectrum DFT results to the analyzer file. For 64bit FDTD simulation,

Observation Points or Observation Area must be present; otherwise simulations will not store any results for further analysis.

Step Action

- 1 From the Draw menu (or the shortcut toolbar), select Observation xy plane.
- 2 Place the **Observation XY Area** in the position after the sphere in the layout.
- 3 Double-click the **observation XY Area**. The **“Observation Properties – X-Y Area” dialog box appears**. Type the following values in the dialog box

General

Center Horizontal Offset (z-drection): **0.1(μm)**

Center Vertical Offset(x-direction): **0.0 μm)**

Center depth (y-direction): **0.2125 (μm)**

X-Length **0.425 (μm)**

Y-Length **0.425 (μm)**

Label: **ObservationArea1**

Data Components

Ex, Ey, Hx, Hy

- 4 Click **OK** to close the dialog box
- 5 Repeat step 1 to step 4 to designer another Observation area at z=0.1um

General

Center Horizontal Offset (z-drection): **0.8(μm)**

Center Vertical Offset(x-direction): **0.0(μm)**

Center depth (y-direction): **0.2125 (μm)**

X-Length **0.425 (μm)**

Y-Length **0.425 (μm)**

Label: **ObservationArea2**

Data Components

Ex, Ey, Hx, Hy

- 6 In the same manner we can put observation point in the layout.



Perform the VB scripting Scanning 64Bit-FDTD Simulation

- | Step | Action |
|------|--|
| 1 | From the Simulation menu, select the “ Simulate 3D using 64-Bit Simulator... ” option. <i>The 3D Simulation Parameters dialog box appears.</i> |
| 2 | Select “Simulate Using VB script. This will do the VB script scanning simulation |
| 3 | Click Run to start the simulation. The progress window appears, it displays status of the simulations. |
| 4 | Visualization of intermediate simulation results. configure the snapshot settings. In the simulation progress window, select “ Simulation ->Take Snapshot ” menu option. The “ Set Snapshot ” dialog box appears <ul style="list-style-type: none"> • Click Browse button to select the location of the output file • Check the observation areas or observation points. The time domain response in the selected observation objects for the current time-step will be save to the file • Click OK to close this dialog box |
| 5 | Click the “ Take Snapshot ” button in the simulation progress dialog box to save the time domain response in the current displayed time step |
| 6 | Go to the folder where the snapshot is saved and with 2D or 3D Viewer observe the time domain response for a certain time step |

Note: the simulation may need some time to finish. Simulation is suggested in the off-work time such as in the night so that you can get the results when you come back to work.

Post-Simulation Data Analysis

The simulation will generate 6 result files with the extension name as FDA. Open one result file can observe the field patterns and power transmission/reflection function:

- | Step | Action |
|------|---|
| 1 | Select “ Observation Area Analysis ” under the “ Tools ” menu in the Analyzer. Select Observation area button to active observation area analysis, Observation Area dialog box appears |
| 2 | Select “ ObservationArea2 ” in the observation area check list |
| 3 | Select wavelength 0.68 from the λ/f list box |
| 4 | Click Update Graph to observe the field pattern for this wavelength. |
| 5 | Select Power Spectrum button, Power Spectrum dialog box appears, Select total Power “Pz”, Check “ Normalize With ” checkbox and click |



Calculate button, **PowerTransmission** spectrum appears. Click **Save As** button will save the transmission spectrum to a file

- 6 Repeat step 6 for each result file, save the transmission spectrum the different file name
- 7 Use OptiFDTD graph tool "**Opti 2D viewer**" to plot the power transmission spectrum in the same graph
 - Select "**Opti 2D viewer**" under Start/All Programs/Optiwave software/OptiFDTD/opti 2D viewer
 - Select "**Add**" under file menu to load each exported transmission spectrum file (refer to [Figure 6](#))

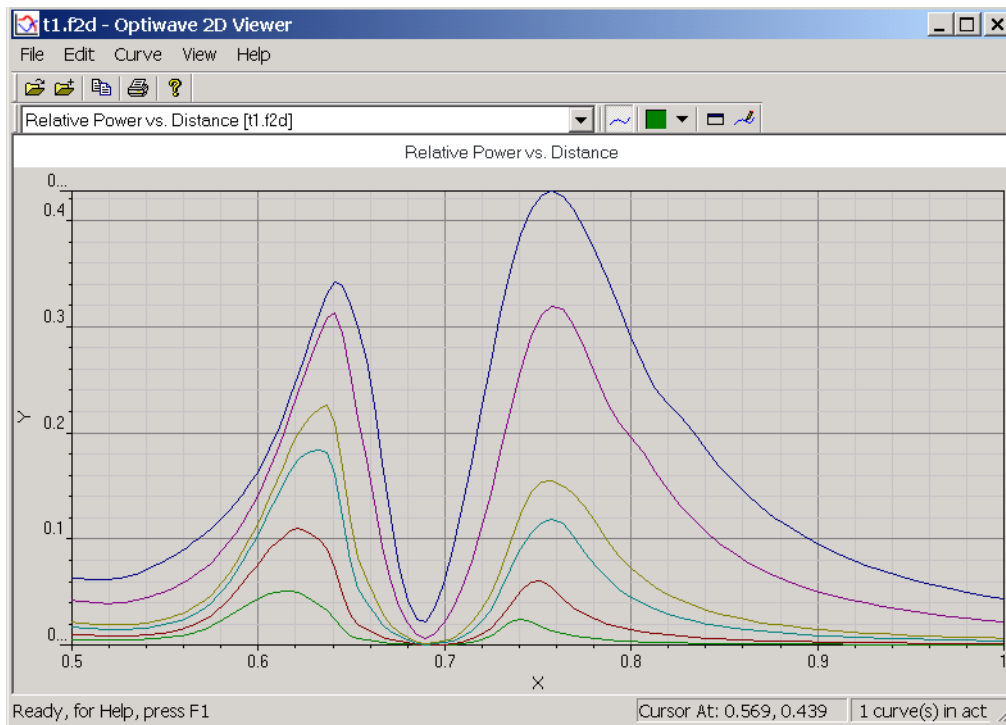


Figure 6 Power transmission spectrum



Lesson 22 - Simulation 3D layout using non-uniform mesh

Since FDTD requires that the entire computational domain be meshed, and the mesh spatial discretization must be sufficiently fine to resolve both the smallest electromagnetic wavelength and the smallest geometrical feature in the model, very large computational domains can be developed, which results in very long CPU times and huge memory usage. For normal dielectric material, numerical dispersion analysis shows that to get accurate results, the mesh size should be at least 10% of the simulated smallest wavelength in medium; for surface plasma layout where metallic material is usually needed, the mesh size should be even smaller to catch the wave attenuation within the skin depth.

The strength for non-uniform FDTD is to save the memory usage and consequently to save the CPU time, for high refractive index region, the fine mesh should be used, while in the low index region, the coarse mesh can be applied. Before we learn the non-uniform mesh simulation in OptiFDTD, we should also discuss several benchmarks for this feature:

- FDTD accuracy refers to the time and space mesh size. Non-uniform mesh FDTD accuracy refers to the largest mesh in the simulation. When numerical dispersion are not in the same level that refers to the mesh size, the largest error that comes from the largest mesh size will be affected and accumulated the whole simulation
- The **Courant-Friedrichs-Lewy condition** (CFL condition) in FDTD method ask the time step must be less than a certain otherwise the simulation will not be stable. The CFL condition for non-uniform mesh FDTD should refers to the smallest mesh size. From this point of viewer the time iteration number does not saved.
- Non-uniform mesh sometimes introduces errors of the geometry representation that is due to a staircase approximation of curved structure surface.
- Boundary condition in each direction for non-uniform mesh will also affect the simulation accuracy.
- When input wave is put in the non-uniform mesh region, it will introduce additional interpolation errors.

The following explains the non-uniform simulation with OptiFDTD. User is supposed already know OptiFDTD design environment and uniform mesh simulations.

Please use OptiFDTD layout designer open sample file named "X64_Sample58_SilverParticle_Non_Uniform_Mesh.FDT". This is a 100nm diameter silver particle putting in a $0.7\ \mu m * 0.7\ \mu m * 0.8\ \mu m$ simulation space. Double click on each object in the layout to check the layout setting.

- Click "**3D Layout Model**" button under the layout window to observe the layout in 3D mode.



- The silver particle center is put at domain center ($x=0\ \mu m$, $y=0.35\ \mu m$, $z=0.4\ \mu m$), so the particle edge is from $-0.05\ \mu m$ to $+0.05\ \mu m$ in x-direction, $0.3\ \mu m$ to $0.4\ \mu m$ in y-direction, $0.35\ \mu m$ to $0.45\ \mu m$ in z-direction.
- The time domain input wave is "Gaussian Modulated Continuous Wave" with center wavelength as $0.5\ \mu m$, bandwidth covers from $0.35\ \mu m$ to $0.65\ \mu m$. (Right click on the spectrum graph and select the zoom in tool to enlarge the selected graph area, this can read the bandwidth)
- Transverse input field pattern is a truncate plane wave (rectangular wave).
- An observation area is put after the sphere, it will detect the transmission spectrum.

Check the memory requirement

- | Step | Action |
|------|---|
| 1 | Select " Simulation 3D Using 64bit Simulator... " under the Simulation menu, 3D Simulation Parameters dialog box appears. |
| 2 | Click advanced button to check the boundary condition setting. |
| 3 | Click Spectrum button to check the spectral information setting. |
| 4 | Unselect Use Non uniform Mesh checkbox in the Nonuniform Mesh Parameters region. Click OK button to close the simulation parameters dialog box. |
| 5 | Repeat step 1 to open the 3D Simulation Parameters dialog box again. The current setting is for uniform mesh simulation, the mesh size is $0.005\ \mu m$. Under the mesh setting region, read the minimum memory requirement is: 175.75M bytes. |
| 6 | Select Use Nonuniform Mesh checkbox in the Nonuniform Mesh Parameters region. Click OK button to close the simulation parameters dialog box. |
| 7 | Open the 3D Simulation Parameters dialog box. The current setting uses the non-uniform mesh. Read the memory usage is 54.28M bytes. |

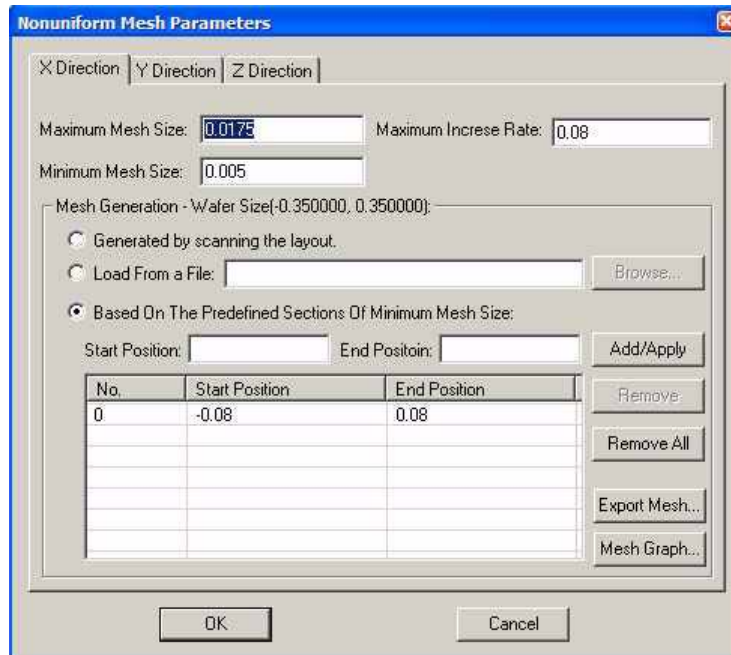


Non-uniform mesh setting

Step Action

- 1 Click **Parameters** in the **Nonuniform Mesh Parameters** region of the **3D Simulation Parameters** dialog box. **Nonuniform Mesh Parameters** dialog box appears. (refer to [Figure 1](#))

Figure 1 Nonuniform Mesh Parameters



Maximum Mesh Size: The maximum mesh size value (unit in ?m) for low refractive index region.

Minimum Mesh Size: The minimum mesh size value (unit in ?m) for high refractive index region.

Maximum Increase Rate: The mesh increase rate η between two neighbor mesh $\Delta_{i\pm 1} = (1 + \eta) \cdot \Delta_i$; η is suggested between 0.01 to 0.5.

A larger mesh increase rate will make the mesh discontinuity too big, which will results in larger simulation errors.

Generated by scanning the layout: When this default mesh generation method is selected, the software will automatically scan the refractive index distribution in one direction. The **Minimum Mesh Size** value will be set to the highest refractive index region, while **Minimum Mesh Size** will be set to the lower index region.

Maximum Increase Rate will be used to smooth the mesh between the maximum and minimum mesh.

Load From a File: OptiFDTD allows the user to generate the mesh. The user can define the mesh grid coordinator value in a text file then load it into OptiFDTD to do the discretization.

Based On the Predefined Sections of Minimum Mesh Size: This discretization method allows the user to define the minimum mesh size region by inputting Start **Position**, End **Position**, then click **Add/Apply** button to make it function in the software. The **Remove** and **Remove All** buttons can remove selected defined regions.

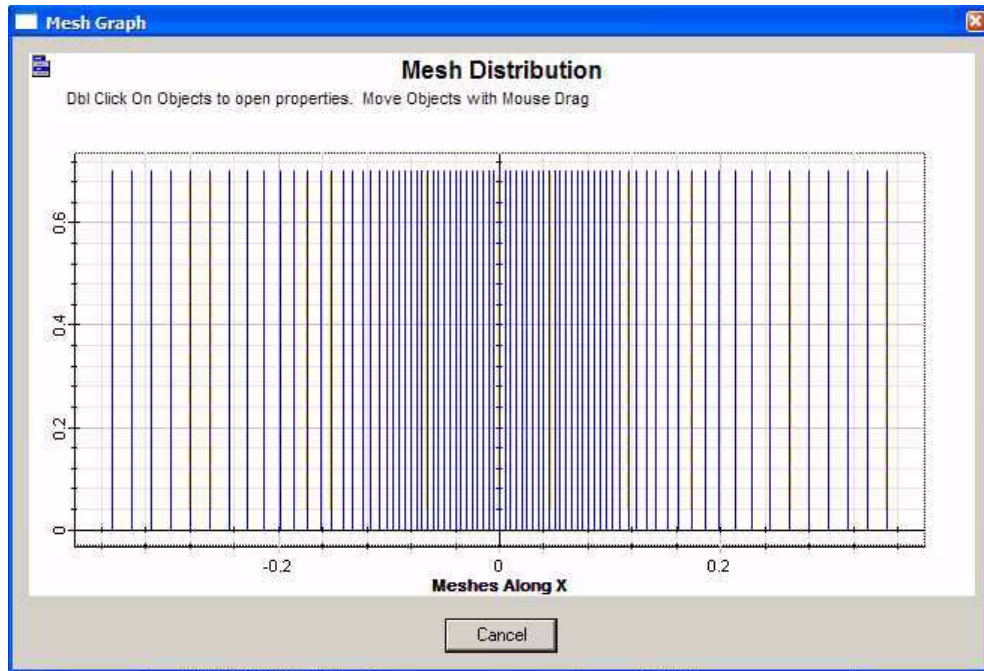
Export Mesh: The mesh grid coordinator can be exported to a text file.

Mesh Graph: Mesh in one direction can be observed in a 2D graph.

- 2 Click **X-Direction** tab to set the x-direction mesh, set the following parameters
 - **Maximum Mesh Size:** $0.0175\mu m$
 - **Minimum Mesh Size:** $0.005\mu m$
 - **Maximum Increase Rate:** 0.08
 - Select **Based On the Predefined Sections of minimum mesh size**, **Start position:** $-0.08\mu m$, **End Position:** $0.08\mu m$. Click **Add/Apply** button. This makes the silver particle in x-direction region use the minimum mesh
 - Click **Export Mesh** button to export the mesh grid coordinator into a file. Use any text editor to open the file and check the mesh grid coordinator values.
 - Click **Mesh Graph** button to observe the x-direction mesh. (Refer to [Figure 2](#)). Click **Cancel** button in mesh graph to return the mesh setting page.



Figure 2 x-direction mesh graph



- 3 Click **Y-Direction** tab to set the y-direction mesh.
 - **Maximum Mesh Size:** $0.0175\ \mu m$
 - **Minimum Mesh Size:** $0.005\ \mu m$
 - **Maximum Increase Rate:** 0.08
 - Select **Based On the Predefined Sections of minimum mesh size**, **Start position:** $0.27\ \mu m$, **End Position:** $0.43\ \mu m$. Click **Add/Apply** button. This makes the silver particle in y-direction region use the minimum mesh.
- 4 Click **Z-Direction** tab to set the Z-direction mesh.
 - **Maximum Mesh Size:** $0.0175\ \mu m$
 - **Minimum Mesh Size:** $0.005\ \mu m$
 - **Maximum Increase Rate:** 0.08
 - Select **Based On the Predefined Sections of minimum mesh size**, **Start position:** $0.325\ \mu m$, **End Position:** $0.475\ \mu m$. Click **Add/Apply** button. This makes the silver particle in z-direction region use the minimum mesh.
- 5 Click **OK** in **Nonuniform Mesh Parameters** dialog box to accept all the settings.
- 6 Click **advanced** button in the **3D Simulation Parameters** dialog box, **Boundary Condition** dialog box appear.
 - X and Y direction boundary set as **PBC**
 - Z direction boundary set as **AMPL**

- **Number of PML Layer:** 16
- **Theoretical Reflection Coefficient:** 1.0e-12
- **Power of Grading Polynomial:** 3.5
- **Real AMPL Tensor Parameters:** 10

Note: The above mesh setting makes the mesh close to the boundary is $0.0175\ \mu m$. So the APML tensor value can be around 5-10, in case of very small mesh around $0.005\ \mu m$, the AMPL tensor value should be around 60-90.

7 Save the new layout setting by clicking save in the file menu.

Perform the 64bit simulation and post data analysis

Step Action

1 Click **Run** button in the **Simulate 3D Using 64bit Simulator** dialog box. 64bit simulation will start.

Note: non-uniform mesh does not support 32bit simulation.

2 After the simulation, open the results in OptiFDTD analyzer.

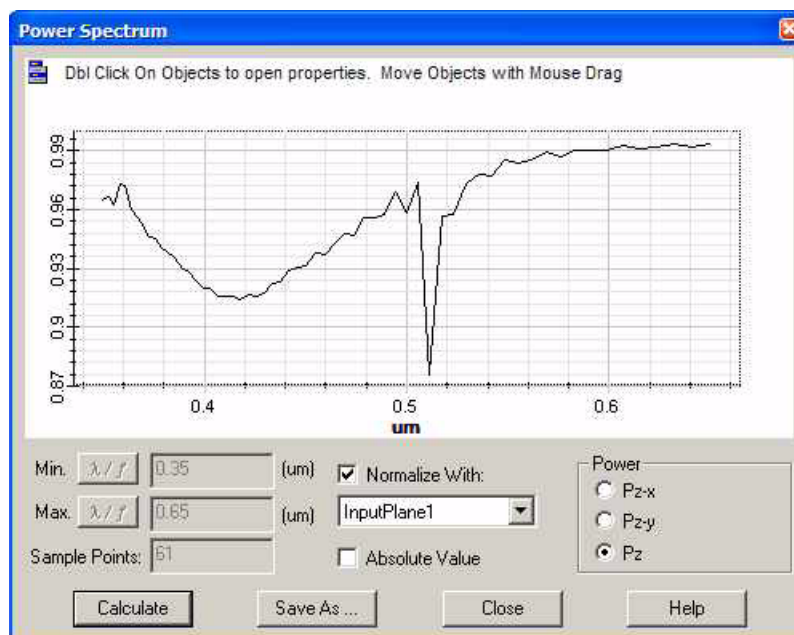
3 Select **Observation Area Analysis** under **Tools** menu of OptiFDTD analyzer. Observation area analysis dialog box appears.

4 Select **Observation Area** tab, then Click **Power Spectrum** button. Power Spectrum dialog box appears.

5 Select **Normalize with InputPlane1**, and select total power **Pz**.

6 Click **Calculate**, Power transmission spectrum appears (refer to [Figure 3](#))

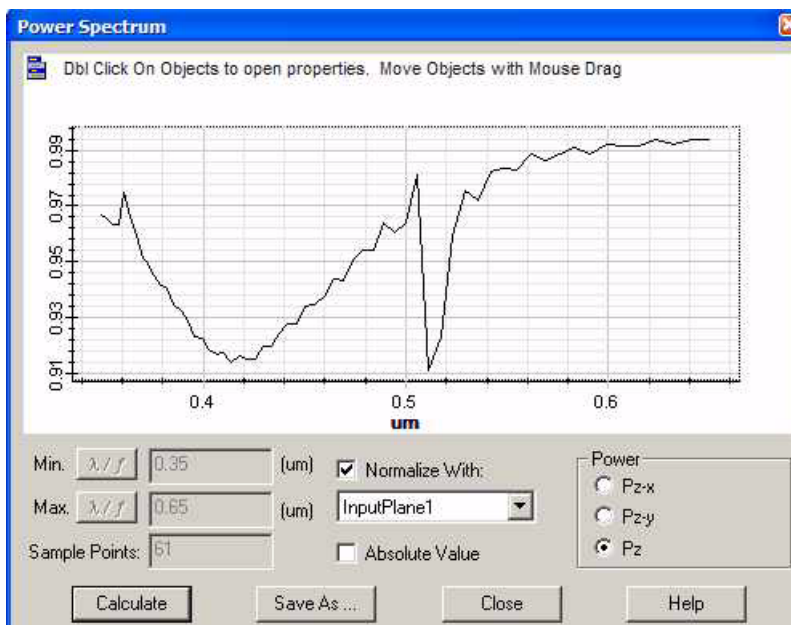
Figure 3 Power transmission spectrum



Using the user defined non-uniform mesh

- | Step | Action |
|------|---|
| 1 | Open the layout we just designed or open the layout named "X64_Sample59_SilverParticle_User_Uniform_Mesh.FDT" in the simple folder. |
| 2 | Open the Nonuniform Mesh Parameters dialog box. |
| 3 | Click X-Direction tab, and select Load From a File . |
| 4 | Click Browse to locate the x-direction mesh file named "Sample59_x_direction_ mesh.txt" in the 64 bit sample folder. You can also open this file by any text editor to check the grid coordinator value. |
| 5 | Click Y-Direction tab, and select Load From a File , Click Browse to locate the y-direction mesh file named "Sample59_y_direction_ mesh.txt" in the 64 bit sample folder. |
| 6 | Click OK button in nonuniform dialog box and 3D simulation parameters dialog box to make the settings function. |
| 7 | Open the simulation dialog box again, the minimum memory requirement is listed as 38.34M bytes. |
| 8 | Run the 64bit simulation. |
| 9 | After the simulation the power transmission spectrum can be obtained. (refer to Figure 4) |

Figure 4 Power transmission spectrum







Optiwave
7 Capella Court
Ottawa, Ontario, K2E 8A7, Canada

Tel.: 1.613.224.4700
Fax: 1.613.224.4706

E-mail: support@optiwave.com
URL: www.optiwave.com